

15. Mechanical Pressure Gauge (dia. 52 mm)

15.2 Technical Data

Movement:	Bourdon tube system
Operating temperature:	- 30°C ... + 85°C
Storage temperature:	- 40°C ... + 90°C
Illumination (option):	1 light bulb 12 V, 2 W or 24 V, 2 W
Protection:	IP40 DIN 40050 from the front
Vibration resistance:	max. 1g eff., 25 ... 500 Hz, duration 8 h, f: 1 octave/min.
Nominal position:	NL 0 to NL 90, DIN 16257
Indication accuracy:	± 4 % of the full range for the last 2/3 of the scale

VDO cockpit international
dia. 52 mm Floodlight

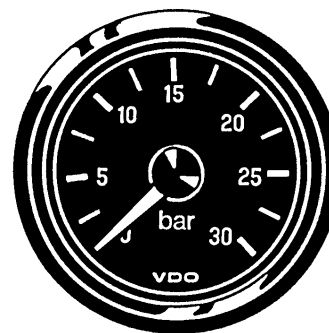

Mounting hole: dia. 53mm

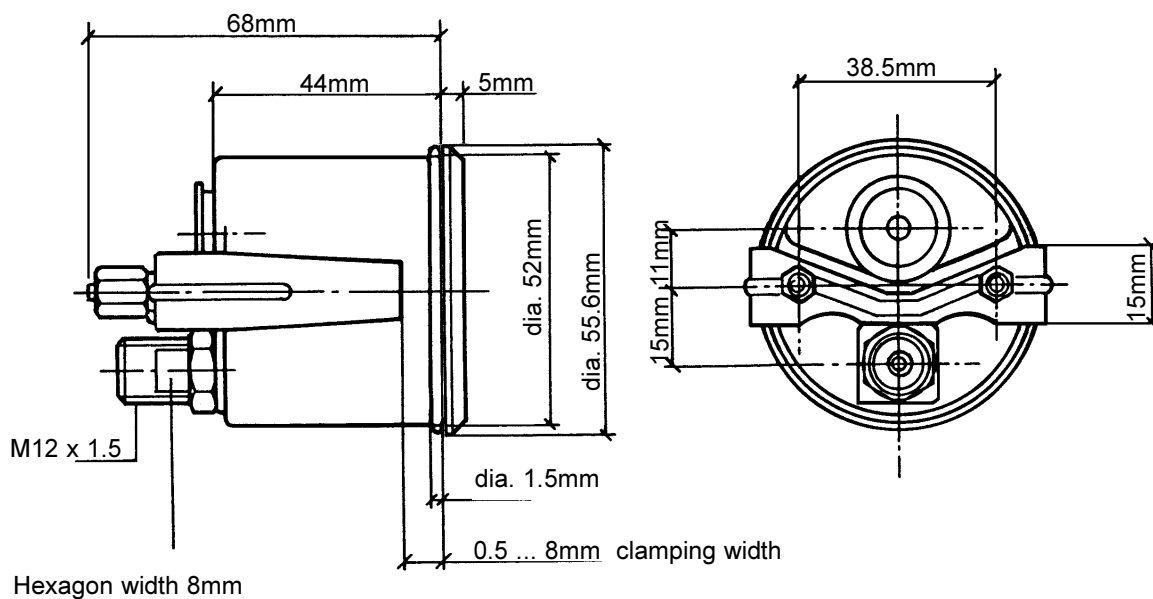

Connecting parts (included):

- a) 1x sleeve for pressure hose
- b) 1x clamp-on termination
- c) 1x union nut (M12 x 1.5, hexagon width 14mm)

