

Warehouse Use Only

Part #	QUANTITY
D015	1
D133	1
CCB	1
CC11S	2
CC12S	2
A471-64	4
CC21	2

Part #:	CC-103B
Dimensions:	71" X 8" X 16"
Weight:	40 Lbs.

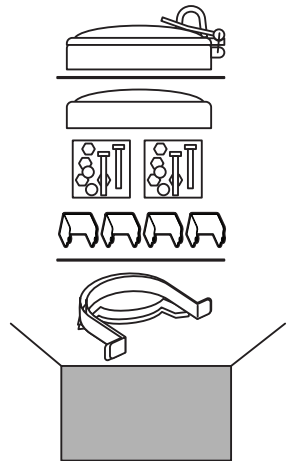

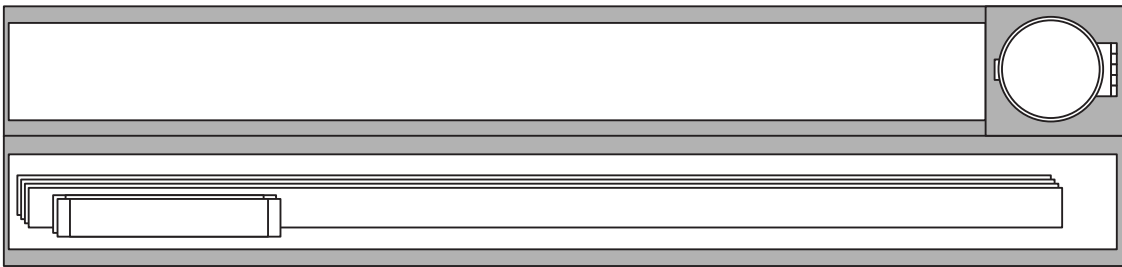
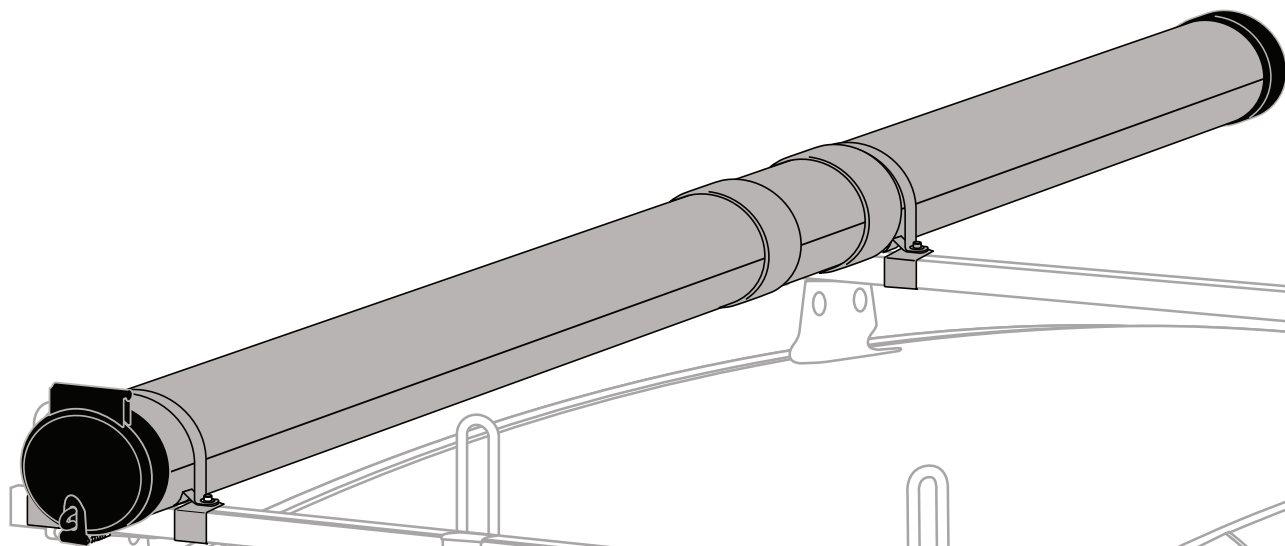

PRODUCT INFO

Part #: CC-103B
Material: Aluminum
Fitment: M-Series
Color: Black

REQUIRED TOOLS

Power Tool With Phillips Head

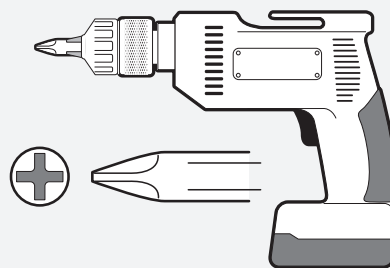



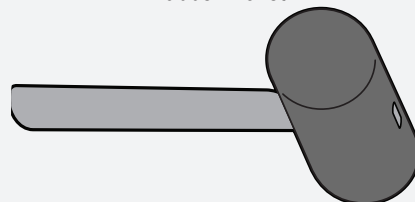



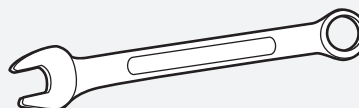







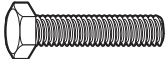

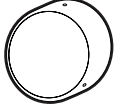
Rubber Mallet



1/2" Wrench X 2



PART #	DESCRIPTION	QTY	ITEM ITEM NOT DRAWN TO SCALE
B201	TAP SCREW	6	
N005	5/16" NYLOC NUT	4	
N002	5/16" NUT	8	
W008	5/16" WASHER	16	
W022	5/16" LOCK WASHER	4	
B025	5/16" X 3" CARRIAGE BOLT	4	
B068	5/16" X 1 3/4" HEX BOLT	4	
A78	2" CONDUIT C BRACKET	4	
A74 (CC)	CONDUIT CAP	1	
A75 (CC)	CONDUIT HATCH	1	
A76 (CC)	CONDUIT BASE	2	
A77 (CC)	CONDUIT U BRACKET	2	
CC11	1/2 CONDUIT TUBE 57"	2	
CC12	1/2 CONDUIT TUBE 71"	2	
A471-64	CONDUIT CARRIER DIVIDER 64"	4	
CC21	CONDUIT STRAP	2	

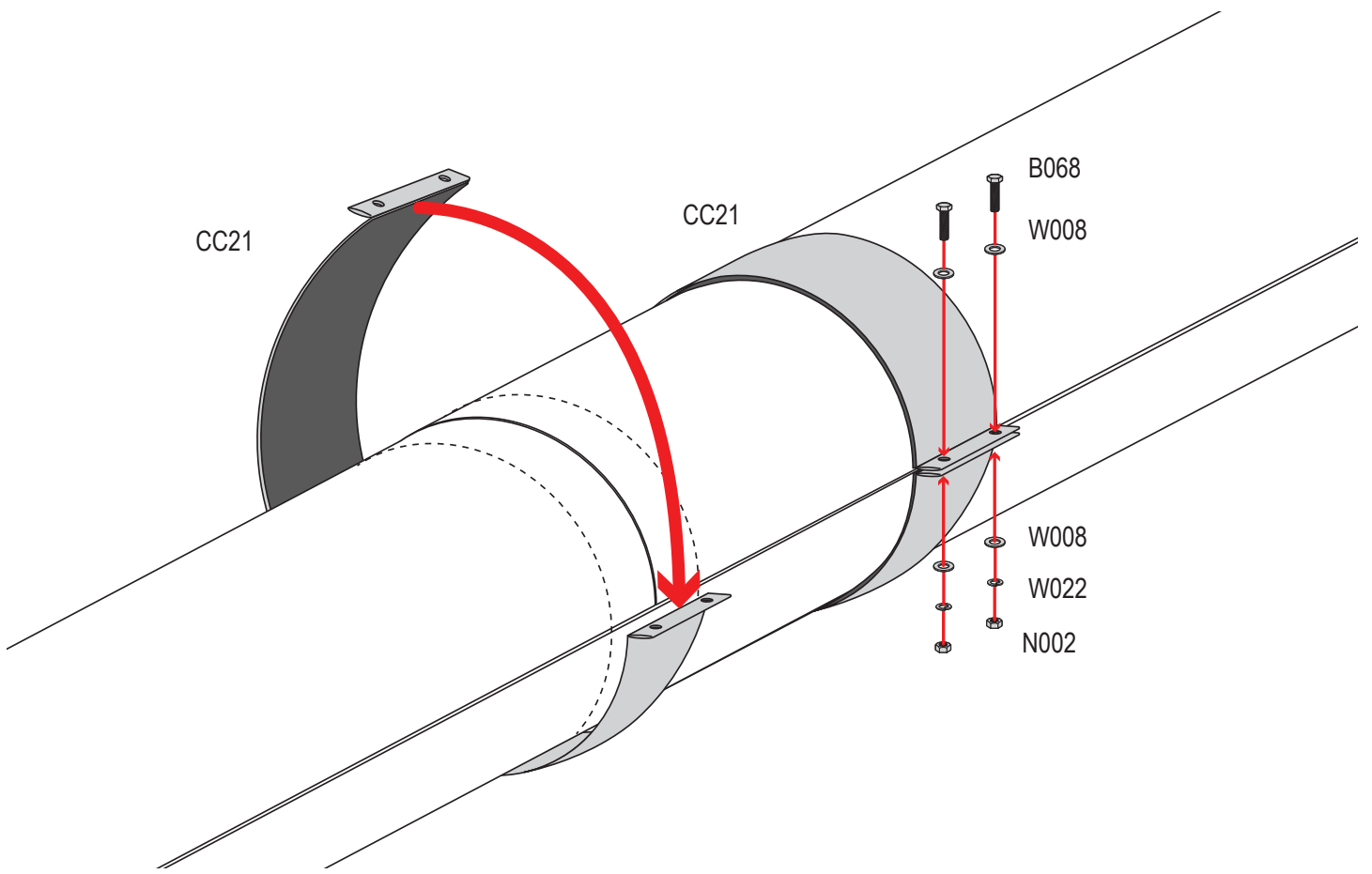
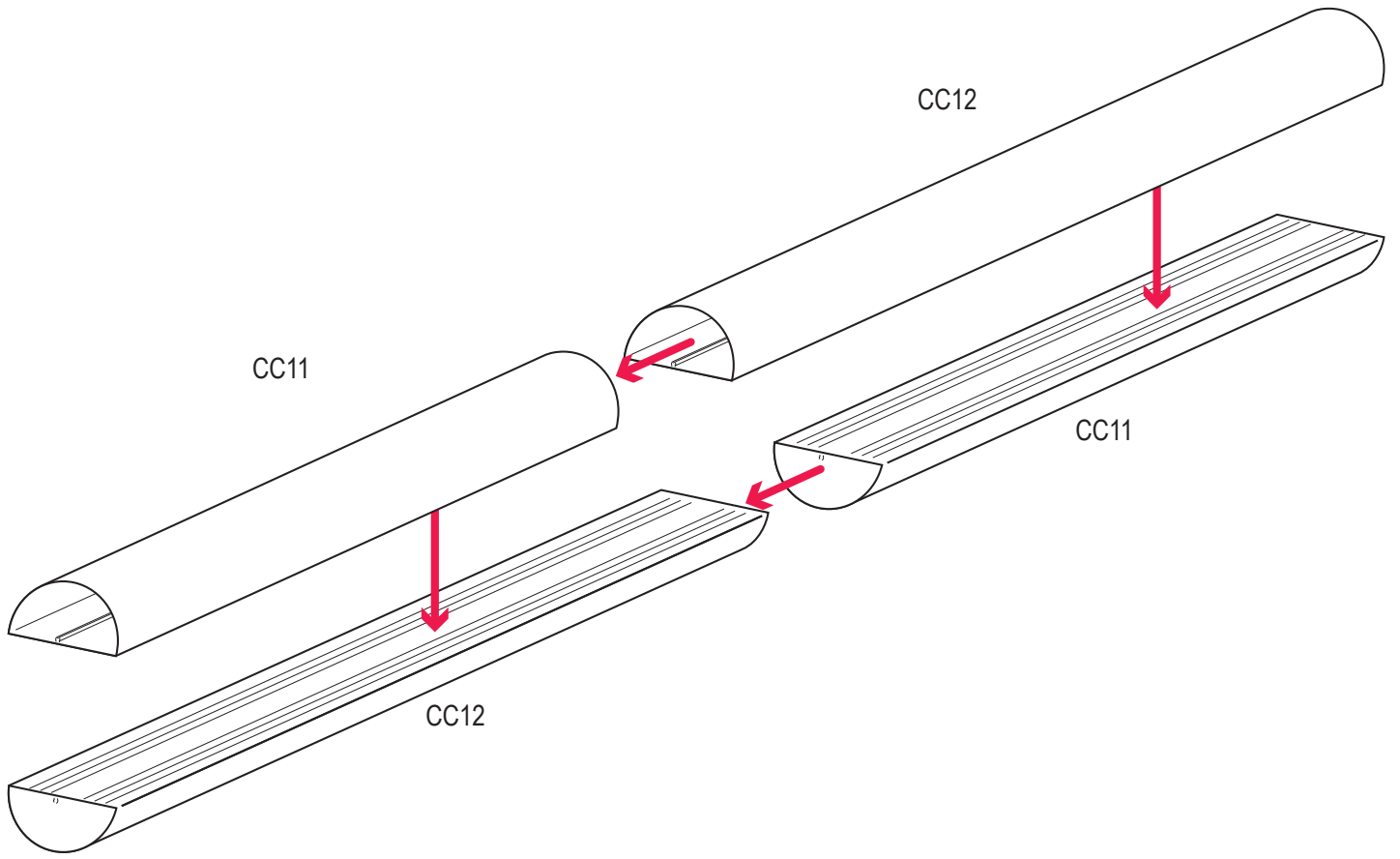

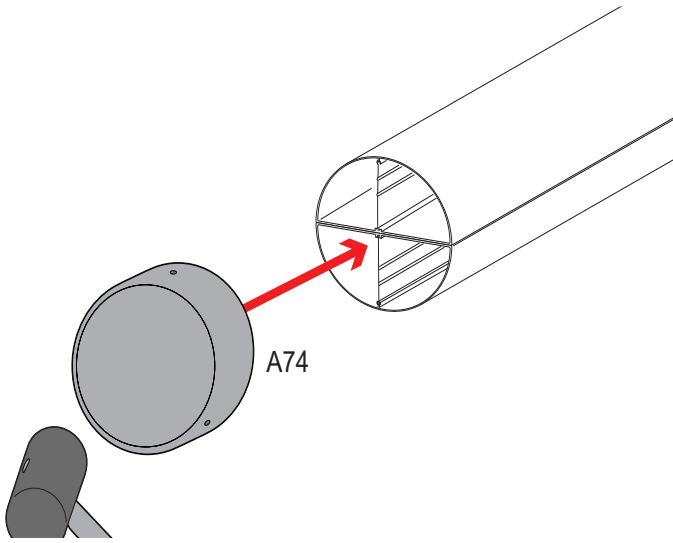

Use a rubber mallet to prevent damage to conduit cap

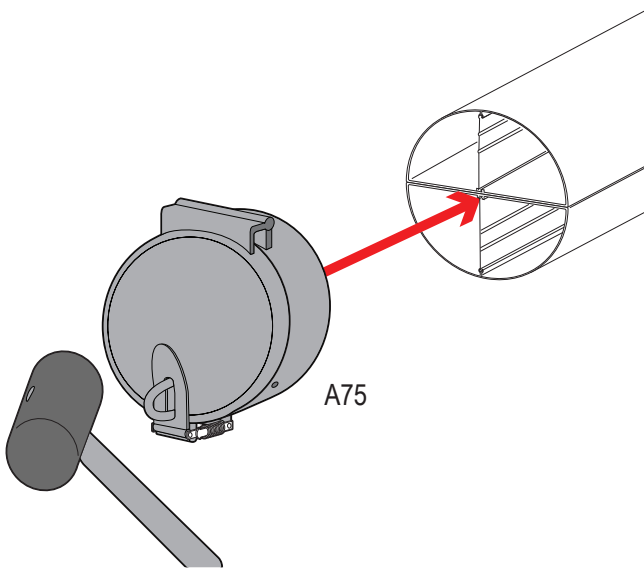
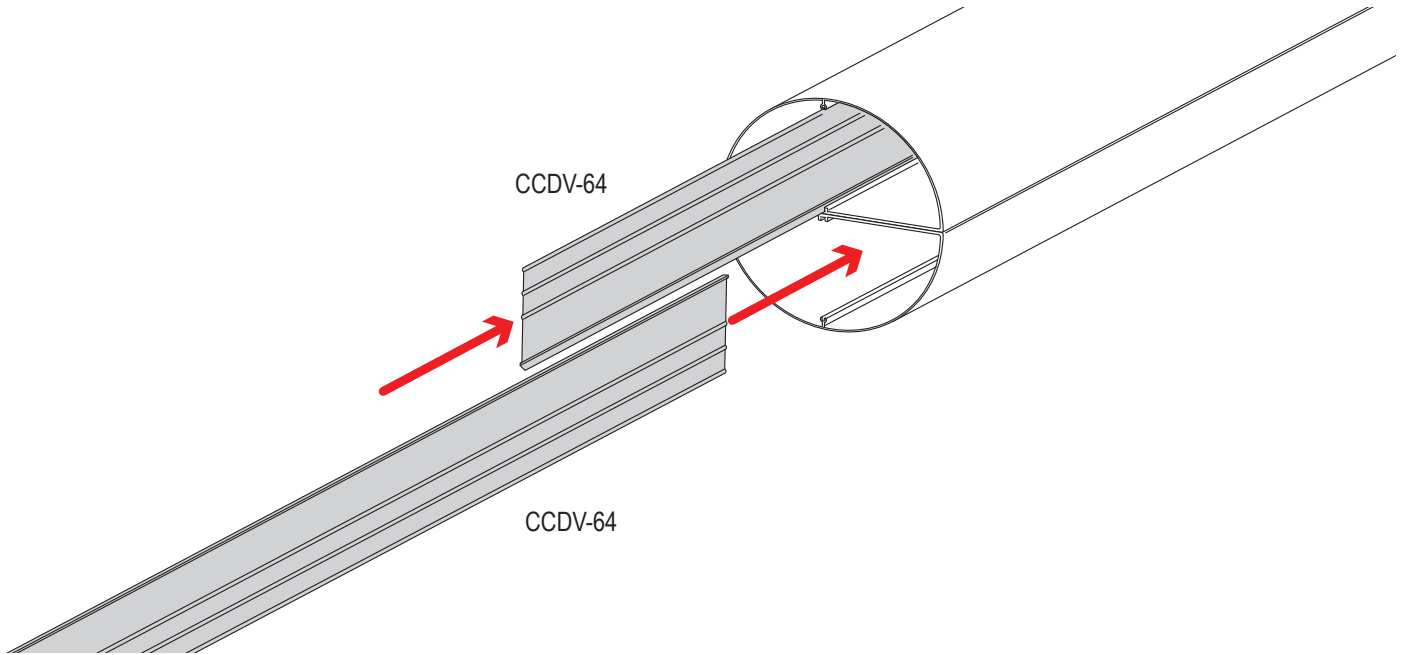
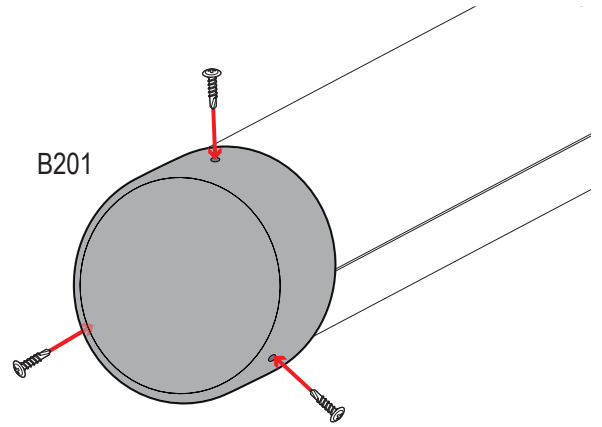

Use a rubber mallet to prevent damage to conduit hatch Rear

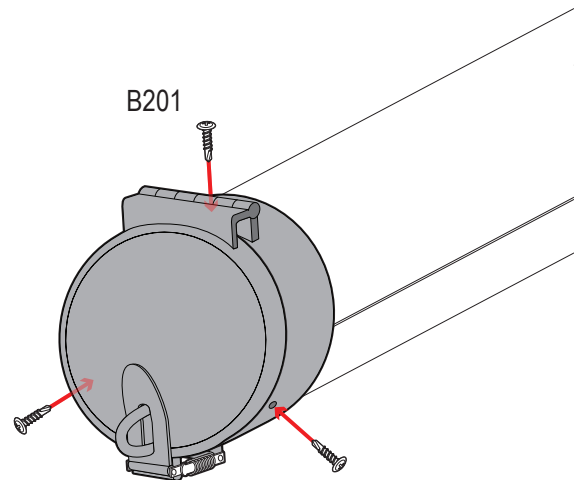

X2 Front & Rear

