

Part #	QUANTITY
D015	1
D132	1
CCB	1
CC11S	2
CC12S	2
A471-64	4
CC21	2

Part #:	CC-102B
Dimensions:	71" X 8" X 16"
Weight:	40 lbs.

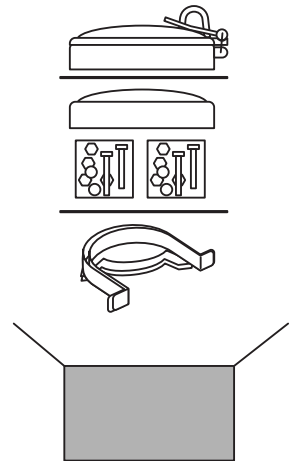

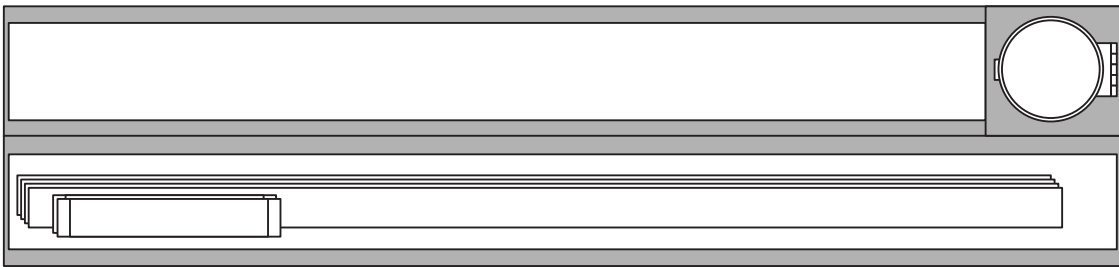
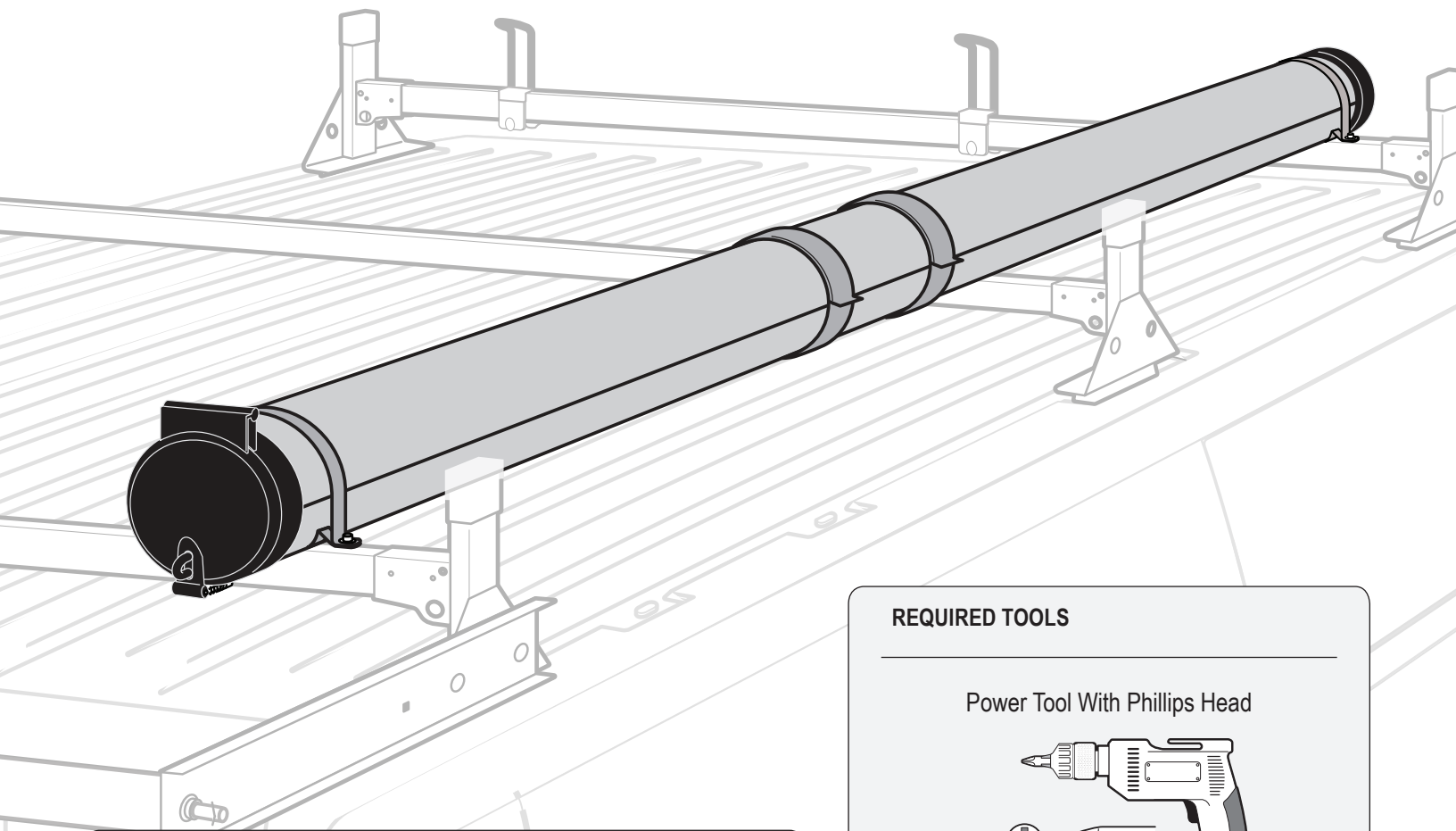

## PRODUCT INFO

Part #: CC-102B  
Material: Aluminum  
Fitment: Universal / Drilling Required  
Color: Black

## REQUIRED TOOLS

Power Tool With Phillips Head

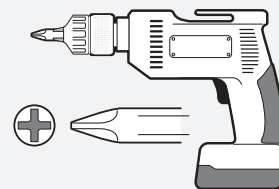

Power Tool With 5/16" Drill Bit

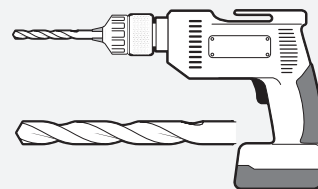



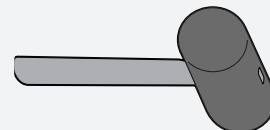



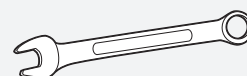

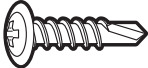

Rubber Mallet

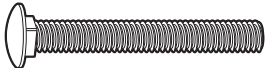
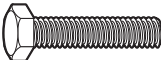
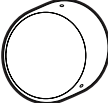

1/2" Wrench

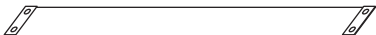

PART #	DESCRIPTION	QTY	ITEM ITEM NOT DRAWN TO SCALE
SS-B201	TAP SCREW	6	
SS-N005	5/16" NYLOC NUT	4	
SS-N002	5/16" NUT	8	
SS-W008	5/16" WASHER	16	
W022	5/16" LOCK WASHER	4	
B025	5/16" X 3" CARRIAGE BOLT	4	
B068	5/16" X 1 3/4" HEX BOLT	4	
A74 (CC)	CONDUIT CAP	1	
A75 (CC)	CONDUIT HATCH	1	
A76 (CC)	CONDUIT BASE	2	
A77 (CC)	CONDUIT U BRACKET	2	
CC11	1/2" CONDUIT TUBE 57"	2	
CC12	1/2" CONDUIT TUBE 71"	2	
A471-64	CONDUIT CARRIER DIVIDER 64"	4	
CC21	CONDUIT STRAP	2	

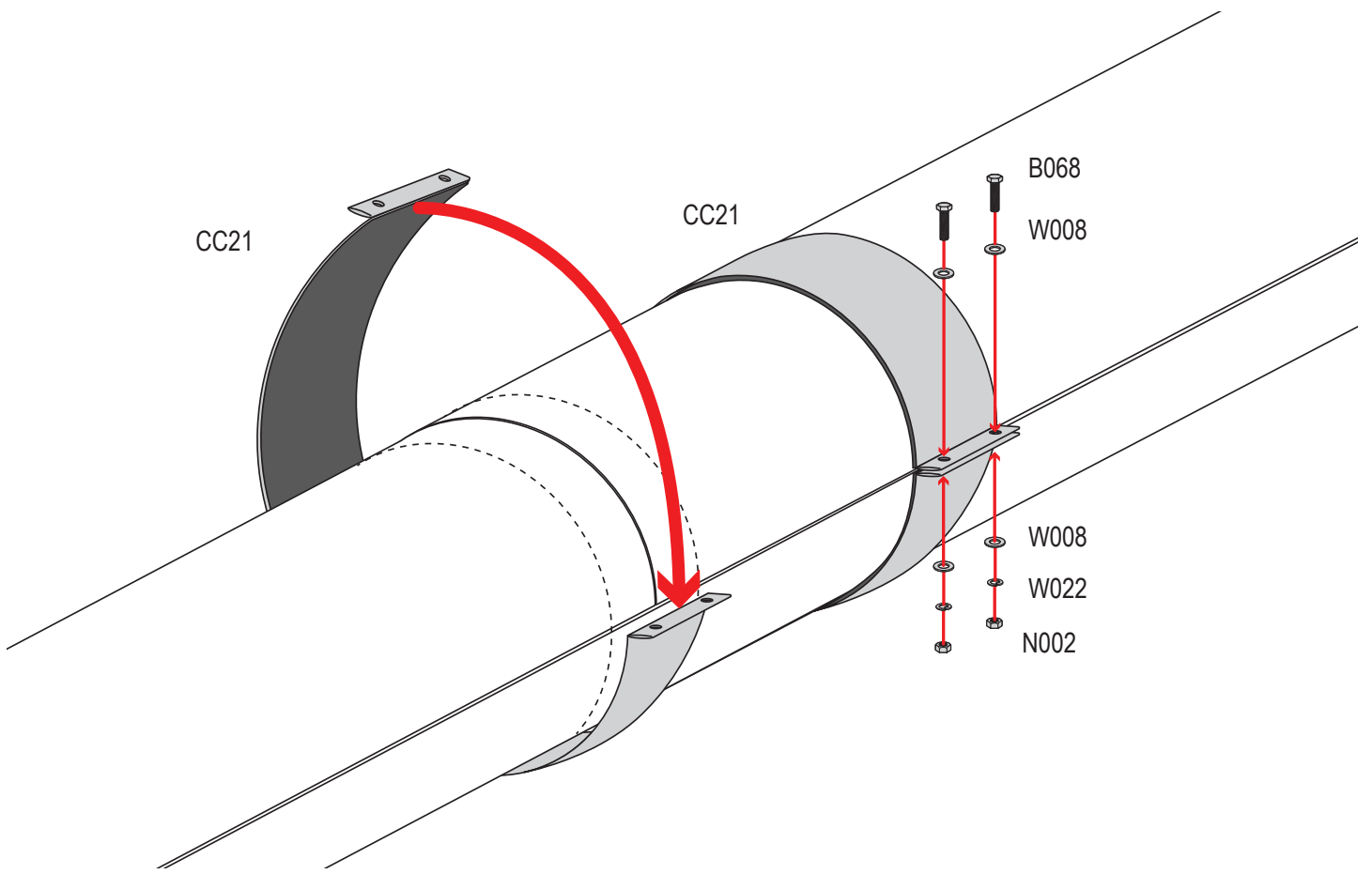
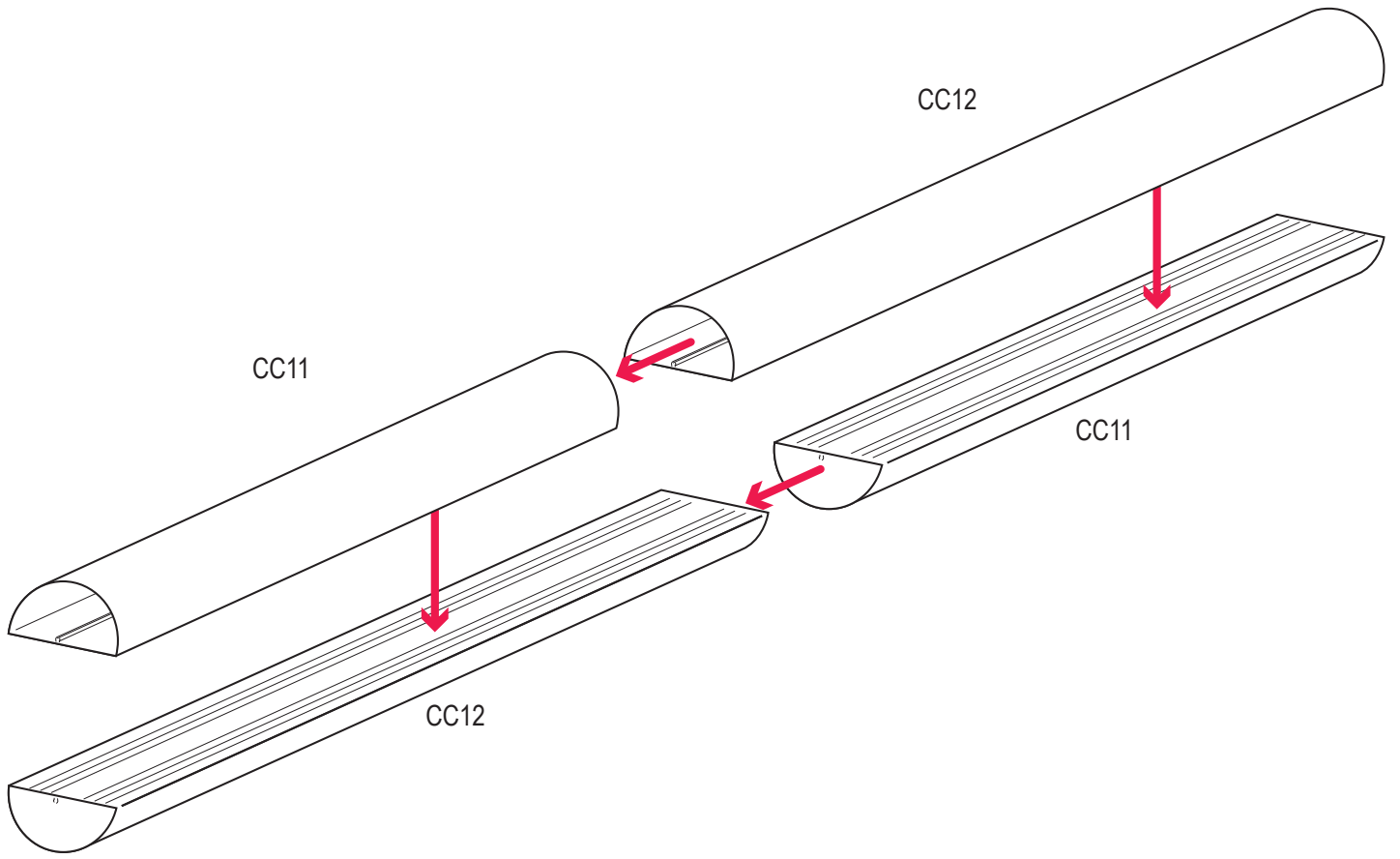

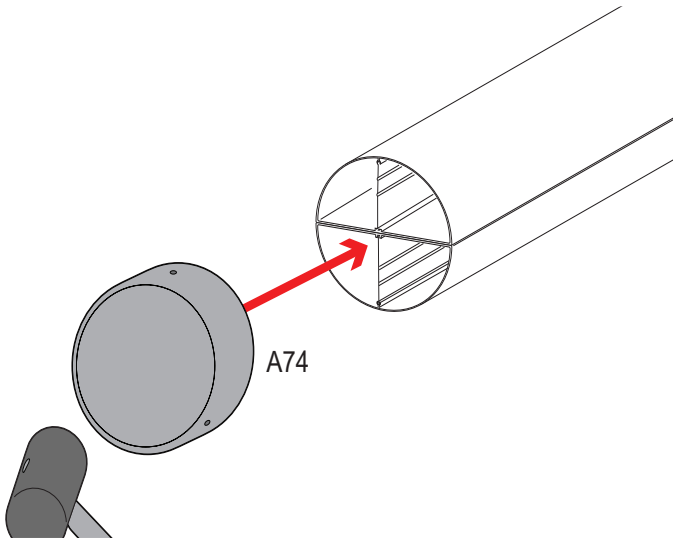

Use a rubber mallet to prevent damage to conduit cap

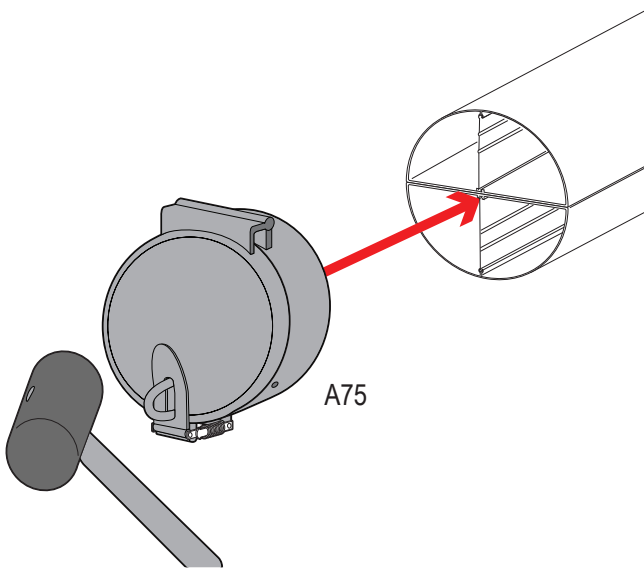
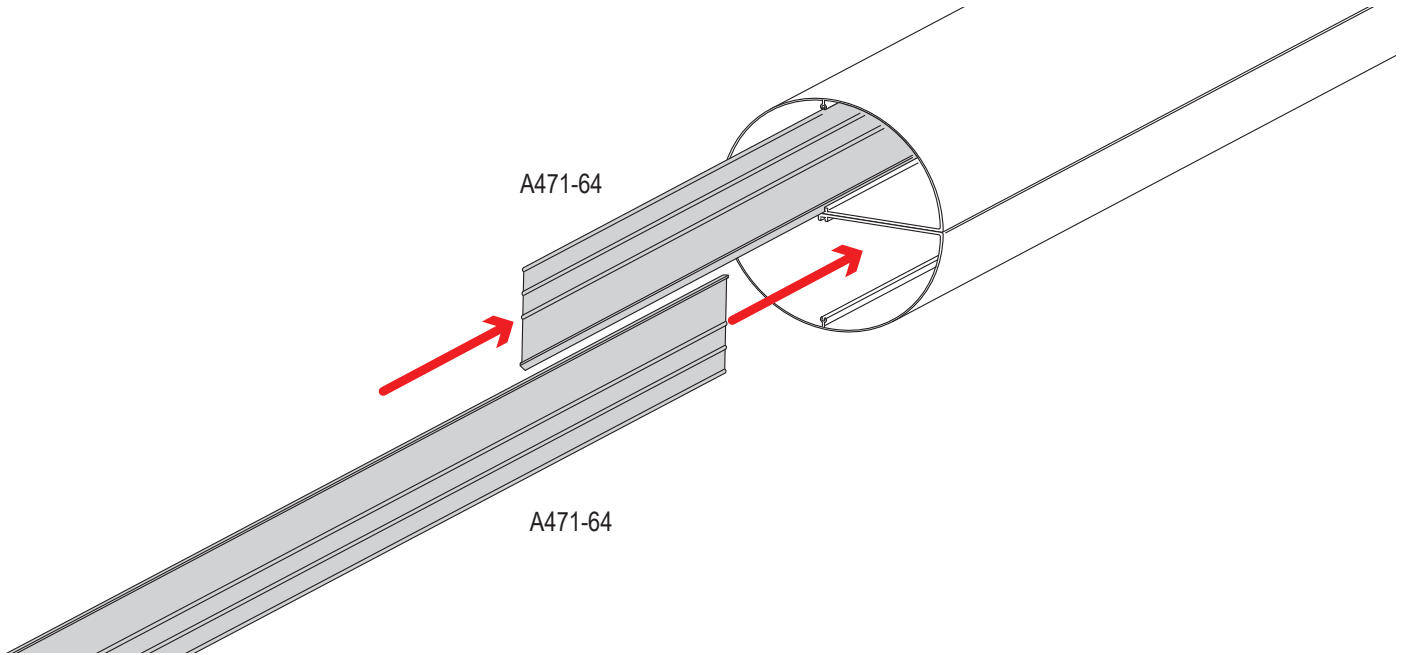
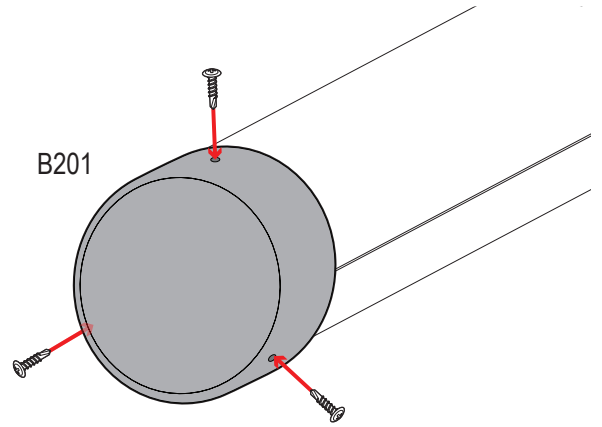

Use a rubber mallet to prevent damage to conduit hatch Rear

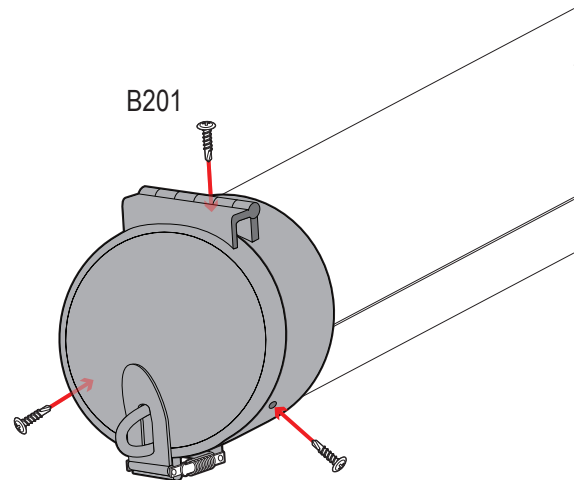

# X2

INSTALL ONTO  
FRONT AND REAR  
CROSS BARS

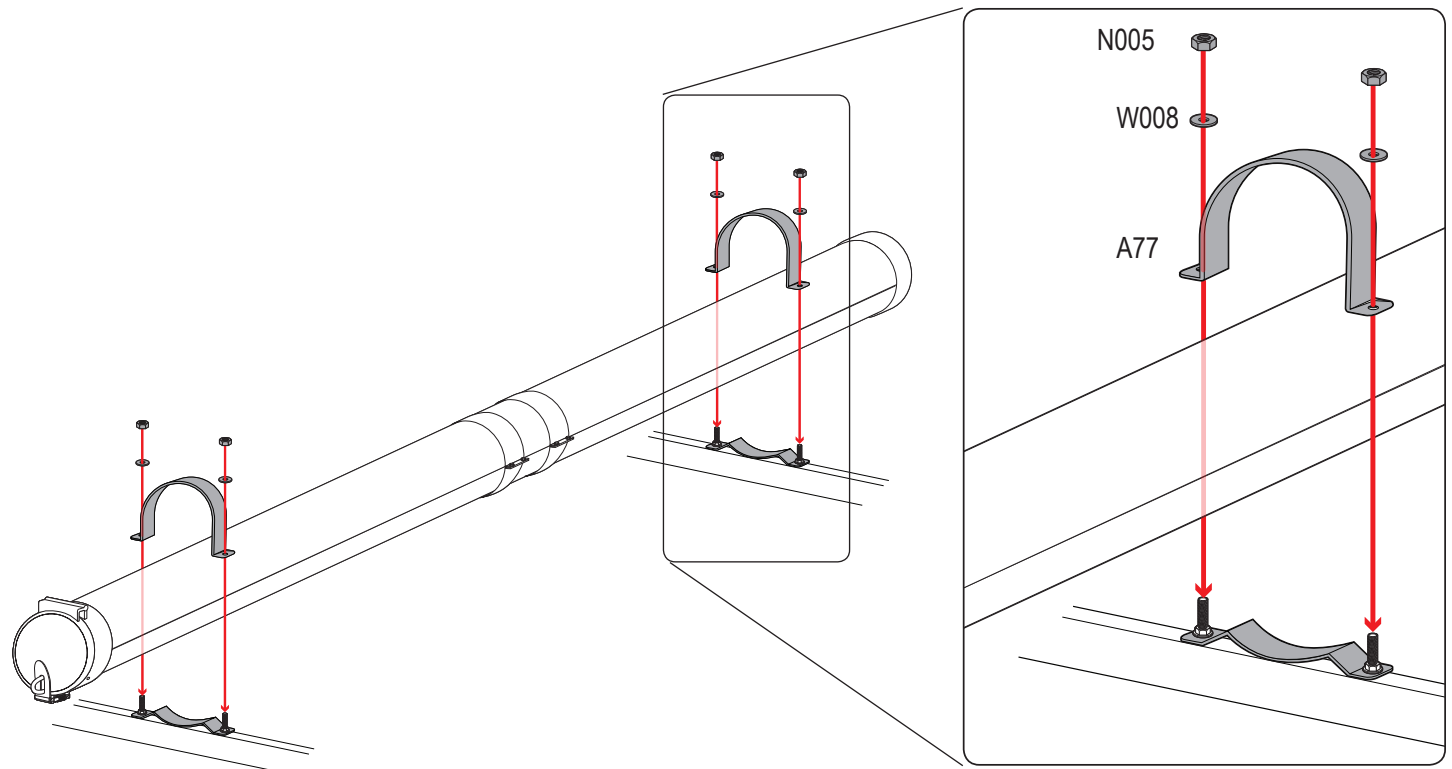
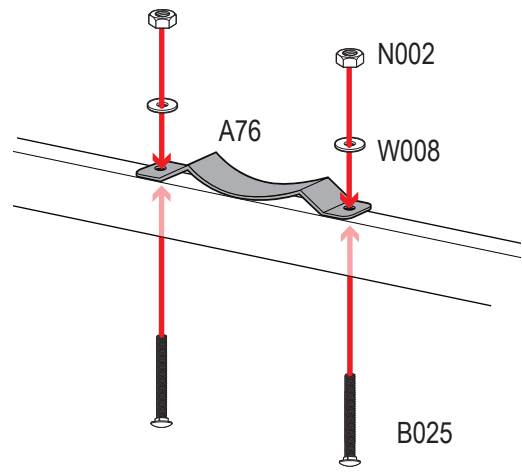
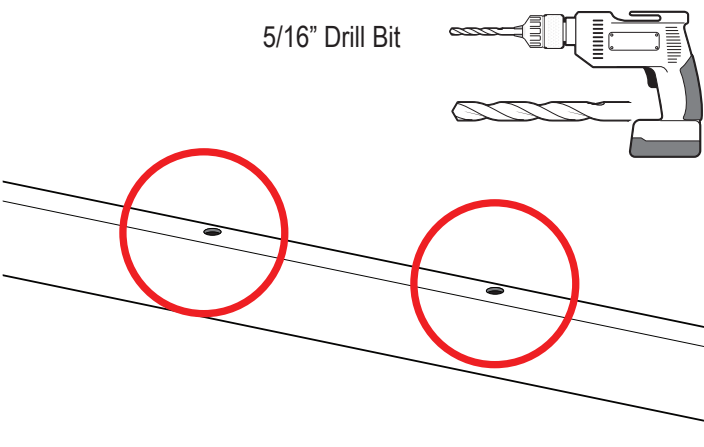
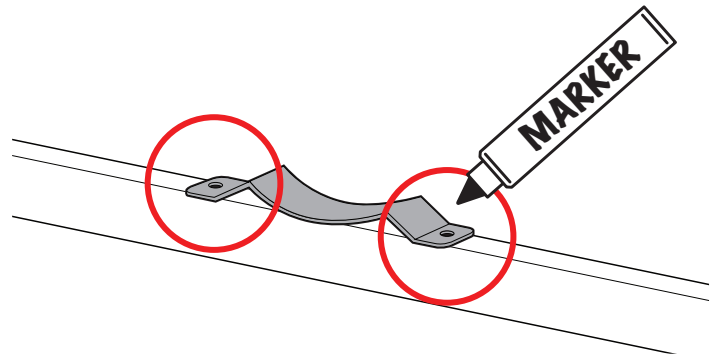
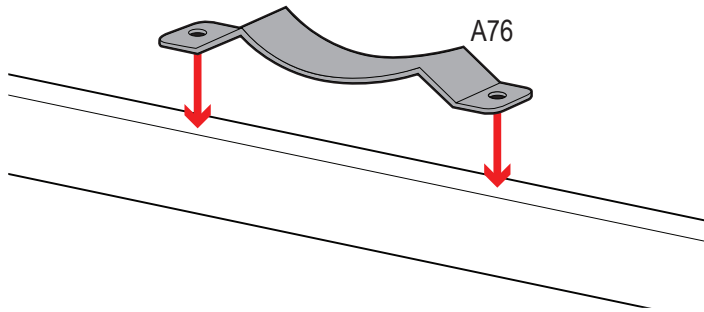

Check out the collection of commercial van equipment we offer.