

## PARTS LIST:

1	Sport Bar	4	12-1.75mm x 35mm Hex Bolts
1	Driver/Left Frame Mounting Bracket	10	12mm x 37mm OD x 3mm Flat Washers
1	Passenger/Right Frame Mounting Bracket	2	12mm Lock Washers
1	Driver/Left Sport Bar Tube Bracket	4	12mm Nylon Lock Nuts
1	Passenger/Right Sport Bar Tube Bracket	4	10-1.25mm x 25mm Hex Bolt ( <b>fine thread</b> )
2	12-1.75mm x 50mm Hex Bolts	4	10mm x 27mm x 3mm Flat Washer
		4	10mm Lock Washer

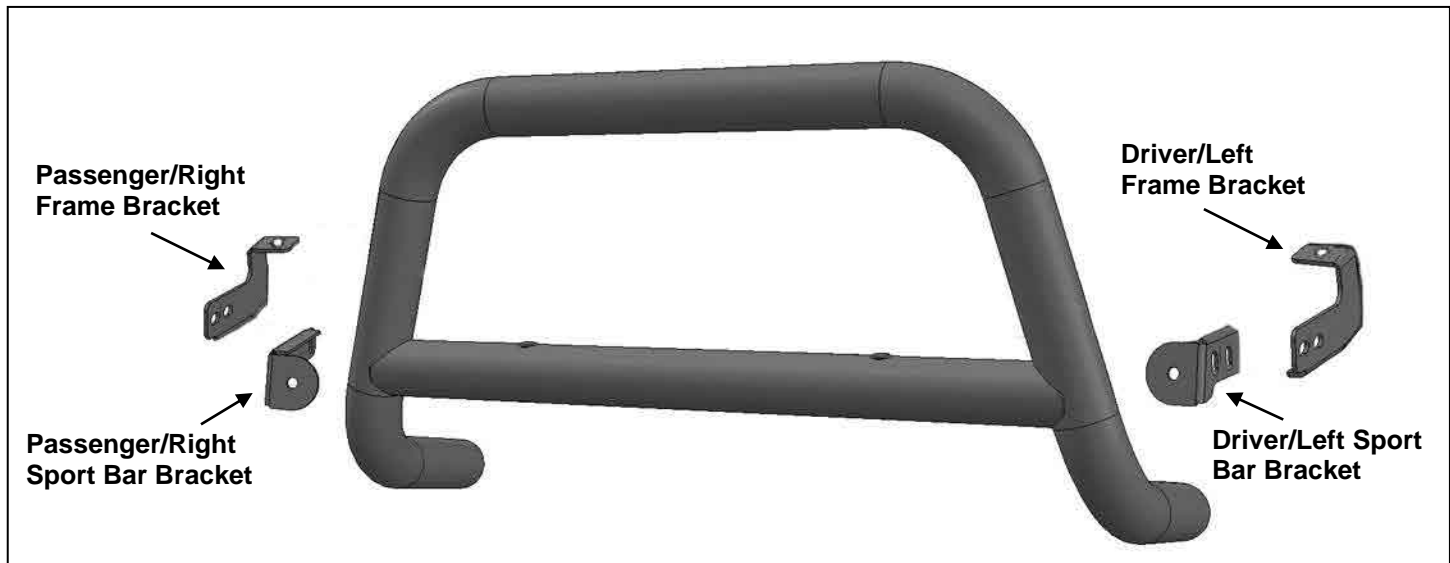

## PROCEDURE:

1. REMOVE CONTENTS FROM BOX. VERIFY ALL PARTS ARE PRESENT. READ INSTRUCTIONS CAREFULLY. CUTTING IS REQUIRED.
2. Select the driver/left Frame Mounting Bracket, (**Figure 1**). Locate the tow hooks welded to the bottom of the subframe, (**Figure 2**). Locate the factory hex bolt directly in front of the driver/left side tow hook, (**Figure 3**). Hold the Bracket up in position against the bottom of the splash guard. Line up the front mounting tab on the Bracket with the hex bolt to check for clearance. The plastic splash guard will require minor trimming to clear the tabs on the Mounting Bracket, (**Figure 4**). Use removable tape (masking tape) to mark the areas to trim. Repeat this Step to mark the passenger side of the splash guard.
3. Remove the splash guard and cut out the areas with a utility knife or hacksaw, (**Figure 4**). Once plastic has been trimmed, reinstall the splash guard with factory hardware. **NOTE:** Cut as little from the splash guard as possible to clear the Brackets. Start with small openings and gradually enlarge cut areas until splash guard clears Brackets. It may be necessary to temporarily reinstall the splash guard several times to check for clearance.
4. Remove the (2) factory hex bolts attaching the crossmember to the bottom of the frame. Snug but do not fully tighten the hardware at this time. **Warning: Do not remove the forward, single hex bolt from the frame. Only loosen hex bolt enough to install Bracket.**
5. Repeat **Step 4** to install the passenger/right Frame Mounting Bracket.
6. Carefully unwrap the Sport Bar and place it on a clean, stable work surface. Select the driver/left Tube Bracket. Attach the Bracket to the end of the Sport Bar with the included 12mm x 50mm Hex Bolt, 12mm Lock Washer and 12mm Flat Washer. Do not tighten hardware. Repeat this Step to attach the passenger/right Tube Bracket to the end of the Sport Bar.

7. Hold the Sport Bar and Brackets up to the (2) Frame Mounting Brackets. Attach the Sport Bar to the inside of the Frame Brackets with the included (4) 12mm x 35mm Hex Bolts, (8) 12mm Flat Washers and (4) 12mm Nylon Lock Nuts.
8. Once the Sport Bar is fully installed, level and adjust the Sport Bar and tighten all hardware.
9. Do periodic inspections to the installation to make sure that all hardware is secure and tight.

**To protect your investment**, wax this product after installing. Regular waxing is recommended to add a protective layer over the finish. Do not use any type of polish or wax that may contain abrasives that could damage the finish.

**For stainless steel:** Aluminum polish may be used to polish small scratches and scuffs on the finish. Mild soap may be used also to clean the Sport Bar.

**For gloss black finishes:** Mild soap may be used to clean the Sport Bar.

### Driver/left Side Bracket Installation Pictured



(Fig 1) Driver/left Frame Mounting Bracket



(Fig 2) Locate the openings for the tow hooks (circled)

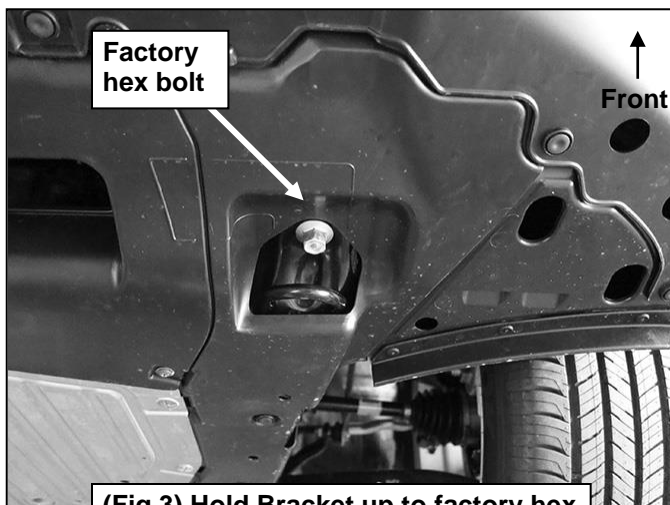

(Fig 3) Hold Bracket up to factory hex bolt to determine approximate area to cut out of splash guard

**Driver/left Side Bracket Installation Pictured**

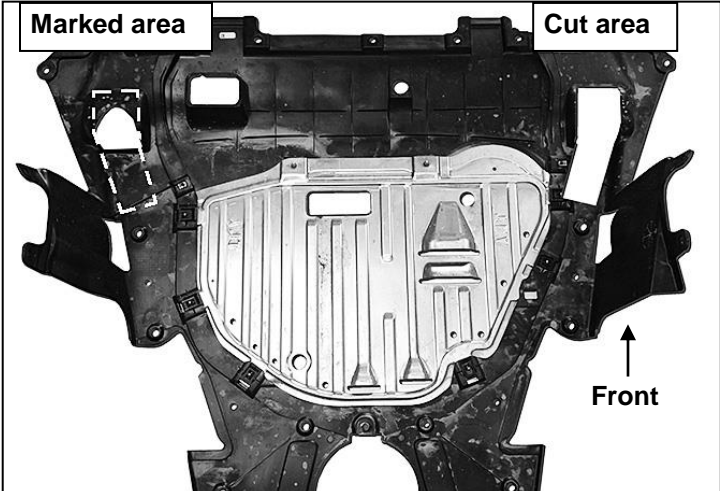

**(Fig 4) Hold Bracket up to factory hex bolt to determine approximate area to cut out of splash guard. Mark location (left) and remove splash guard. Cut out both areas as required to clear Brackets (right). Areas marked and cut pictured for example only**



### Driver/left Side Bracket Installation Pictured

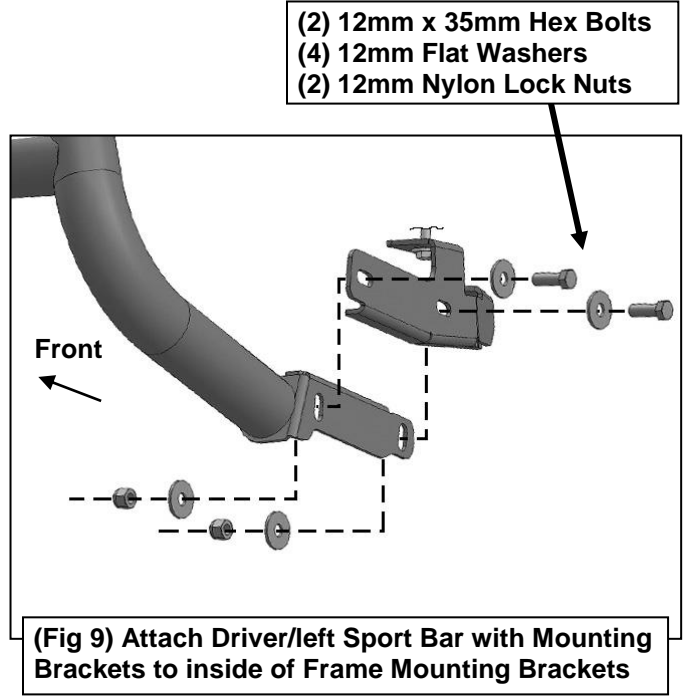
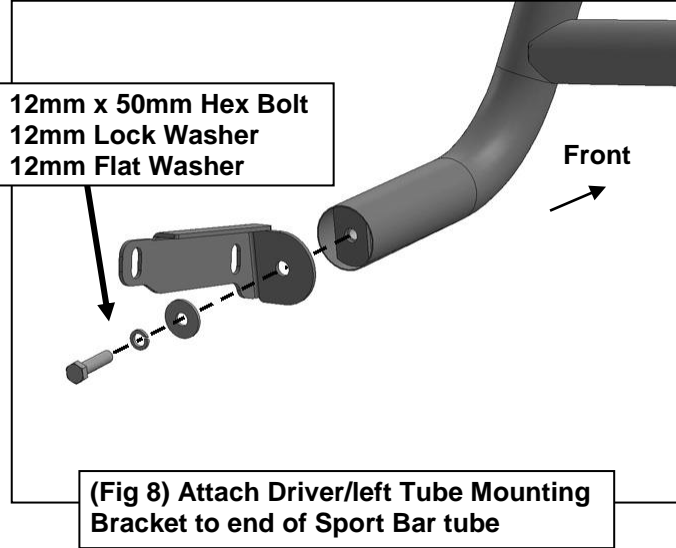

A. Parts List



B. Letters match which slots line up



C. Install as illustrated below

