

PARTS LIST:

1	Top bend	4	12mm Hex Nuts
1	Middle Tube	12	10-1.5mm x 30mm Button Head Bolts
1	Driver/Left Side Bend	12	10.5mm x 25mm OD x 2mm Flat Washers
1	Passenger/Right Side Bend	12	10mm Lock Washers
1	Driver/Left Sub Plate	1	6mm Insert Tool
1	Passenger/Right Sub Plate	2	6-1.0mm Threaded Inserts
1	Sand Baffle Plate	4	6-1.0mm x 25mm Button Head Bolts
1	Driver/Left Frame Mounting Bracket	1	6-1.0mm x 35mm Hex Bolt (use for insert only)
1	Passenger/Right Frame Mounting Bracket	2	6-1.0mm x 25mm Hex Bolts
1	Driver/Left Frame Top Support Brackets	1	6mm x 22mm OD x 2mm Large Flat Washer
1	Passenger/Right Frame Support Brackets	8	6mm x 18mm OD x 1.2mm STD Flat Washers
2	Connecting Bracket	6	6mm Lock Washers
4	12-1.75mm x 30mm Hex Bolts	3	6mm Hex Nut
8	12mm x 30mm OD x 2mm STD Flat Washers	1	6mm Allen key
4	12mm Lock Washers	1	4mm Allen key

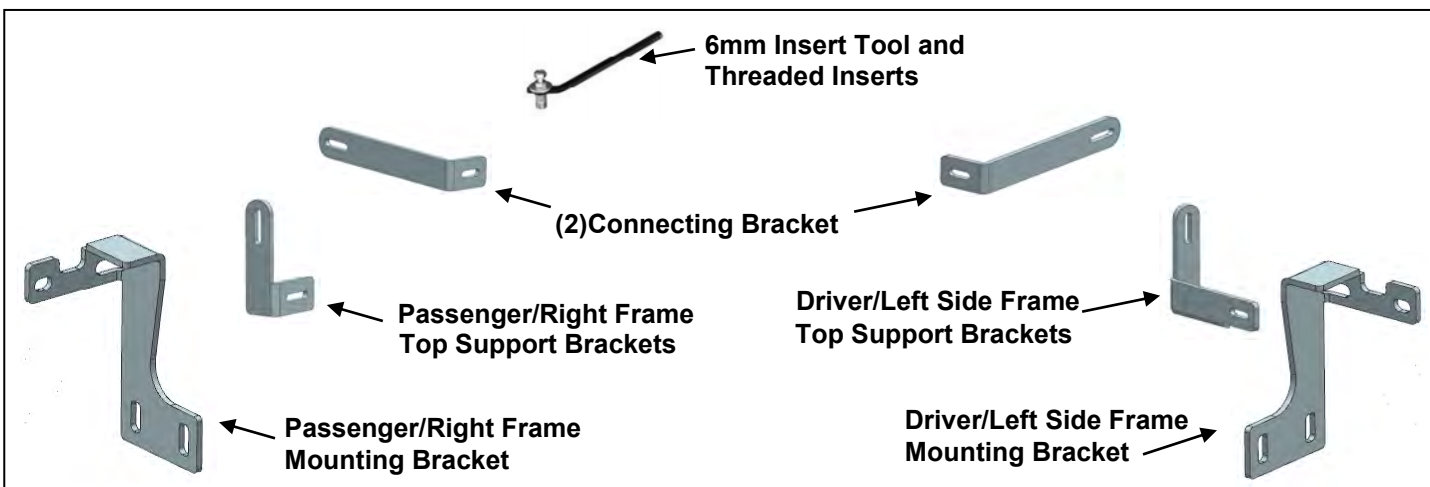

PROCEDURE:

REMOVE CONTENTS FROM BOX. VERIFY ALL PARTS ARE PRESENT. READ INSTRUCTIONS CAREFULLY BEFORE STARTING INSTALLATION. ASSISTANCE IS RECOMMENDED. CUTTING IS REQUIRED.

1. Start installation under the passenger side of the front bumper. Remove the splash guard, **(Figure 1)**.
2. Next, locate and remove the (2) factory lower bumper bracket bolts only, **(Figure 3)**.
3. Select the passenger side Frame Mounting Bracket, **(Figure 2)**. Attach the Bracket to the front of the bumper bracket with the (2) factory hex bolts, **(Figure 3)**. Do not tighten hardware at this time.
4. Repeat **Steps 1—3** to install the driver side Frame Mounting Bracket.
5. Determine if the vehicle is equipped with an oil cooler bolted to the top/back of the steel impact bumper.

Models without oil cooler:

- a. Open the hood. Remove the plastic center section of the 3-piece front bumper cover, **(Figure 4A)**.
- b. Locate the factory holes in the back of the steel impact bumper, **(Figure 4B)**. **IMPORTANT:** The Top Brackets will attach to factory holes offset toward the driver side. Inserts cannot be removed once installed. If necessary, hold the Grille Guard up in position on the outside of the Frame Brackets. Line up the threaded inserts in the bottom of the grille guard with the mounting holes in the back of the bumper, **(see Figures 12 & 13)**.
- c. Mark the correct holes in the bumper before installing inserts.
- d. Select (1) 6mm Threaded Insert, (1) 6mm x 35mm Hex Bolt, (1) 6mm x 22mm Large Flat Washer, (1) 6mm Hex Nut and the Insert Tool, **(Figure 5A)**. Assemble the Tool as shown in **Figure 5B**. Push the Tool and Insert assembly into the correct factory hole in the back of the steel bumper.

- e. Hold the 6mm Hex Bolt in position with a 10mm Wrench and slowly tighten (turn clockwise) the 6mm Hex Nut until the Insert is fully locked in place, **(Figure 6)**. **NOTE:** Do not over tighten or damage to the Insert may occur. Once Insert is fully compressed, remove the Hex Bolt and Tool from the Insert.
- f. Repeat the previous **Steps d & e** to install the second Insert in the driver side, **(Figures 4A—6)**.
- g. Select the (2) Top Mounting Brackets. Attach the Brackets to the Threaded Inserts with (2) 6mm x 25mm Hex Bolts, (2) 6mm Lock Washers and (2) 6mm Flat Washers, **(Figure 7)**.
- h. Snug but do not tighten hardware at this time.
- i. Reinstall the plastic bumper cover.

Models with oil cooler:

- a. From below the bumper, remove the (2) factory hex bolts attaching the brackets on the oil cooler to the back of the impact bumper, **(Figures 8 & 9A)**.
 - b. Insert the Top Brackets between the oil cooler brackets and the bumper, **(Figures 9A—9C)**.
 - c. Attach the Brackets with the included (2) 6mm x 25mm Hex Bolts, (2) 6mm Lock Washers and (2) 6mm Flat Washers, **(Figures 9A—9C)**.
 - d. Snug but do not tighten hardware at this time.
6. With assistance, place the Grille Guard up to the outside of the Frame Brackets. Attach the Grille Guard to the Brackets with (4) 12mm x 35mm Hex Bolts, (8) 12mm x 24mm STD Flat Washers, (4) 12mm Lock Washers and (4) 12mm Hex Nuts, **(Figure 10)**. Snug but do not tighten hardware at this time.
 7. Next, select the driver side outer wing. Attach the wing to the center Grille Guard with (4) 8mm x 30mm Hex Bolts, (8) 8mm Flat washers and (4) 8mm Nylon Lock Nuts, **(Figure 11)**. Tighten the wing hardware at this time. Repeat to attach the passenger side wing to the grille guard.
 8. Line up the Top Brackets with the threaded inserts in the bottom of the crossbar. Attach the Brackets to the crossbar with (2) 6mm x 20mm Button Head Bolts, (2) 6mm Lock Washers and (2) 6mm x 18mm STD Flat Washers, **(Figures 12 & 13)**. Do not fully tighten hardware at this time.
 9. Align and adjust the Grille Guard and fully tighten all hardware at this time.
 10. Hold the plastic splash guard up to the bottom of the passenger side Mounting Bracket, **(Figure 14)**. Trace the location of the Bracket onto the inside of the plastic cover. Use a sharp knife or hacksaw blade to cut out the section from the cover. Reinstall the splash guard.
 11. Do periodic inspections to the installation to make sure that all hardware is secure and tight.

To protect your investment, wax this product after installing. Regular waxing is recommended to add a protective layer over the finish. Do not use any type of polish or wax that may contain abrasives that could damage the finish.

For stainless steel: Aluminum polish may be used to polish small scratches and scuffs on the finish. Mild soap may be used also to clean the Grille Guard.

For gloss black finishes: Mild soap may be used to clean the Grille Guard

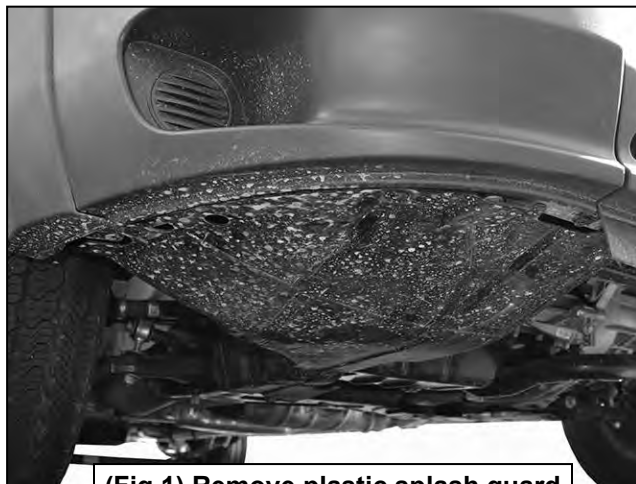

(Fig 1) Remove plastic splash guard



(Fig 2B) Passenger/right side Mounting Bracket

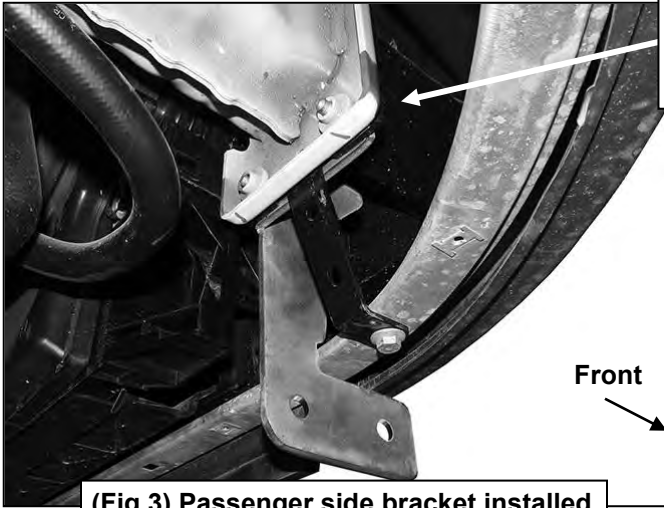

(Fig 3) Passenger side bracket installed

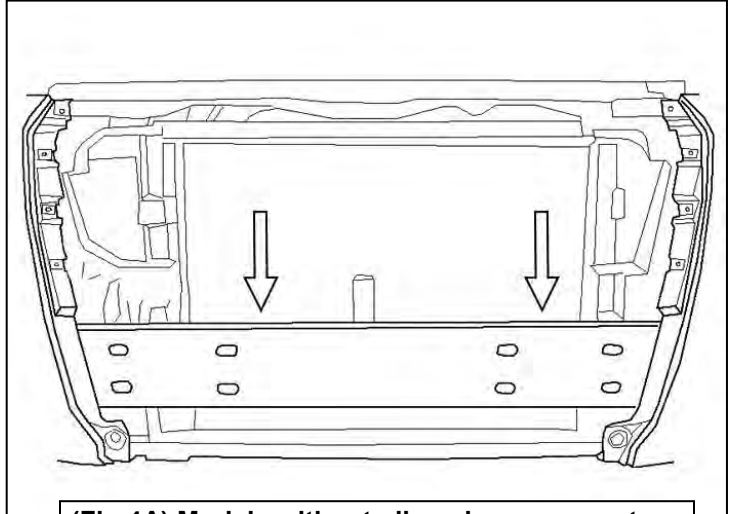

(Fig 4A) Models without oil cooler: once center bumper cover is removed, locate the holes in the back of the steel impact bumper (arrows)

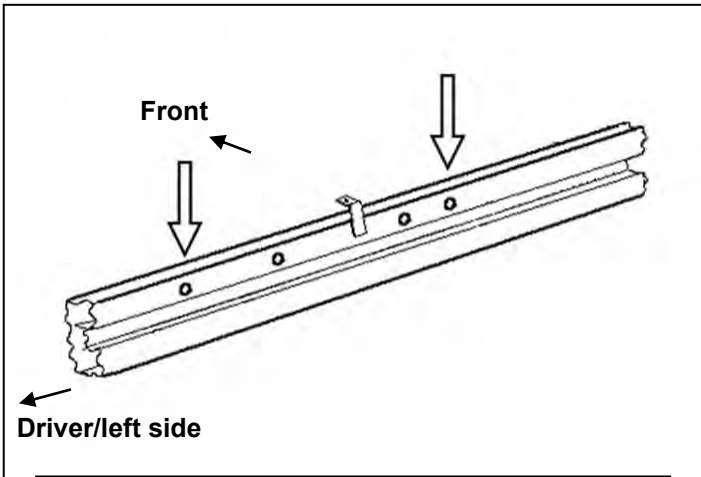

(Fig 4B) Back of steel inner bumper illustrated. NOTE: locate mounting holes offset to left side

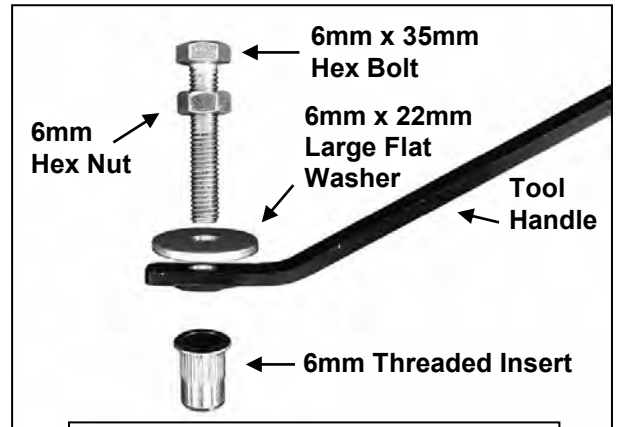

(Fig 5A) Assemble 6mm Insert Tool

Hold 6mm Hex Bolt in position with wrench. Turn 6mm Hex Nut clockwise to "pull" insert



(Fig 5B) Assemble 6mm Insert Tool



(Fig 6) Example of fully installed 6mm Insert

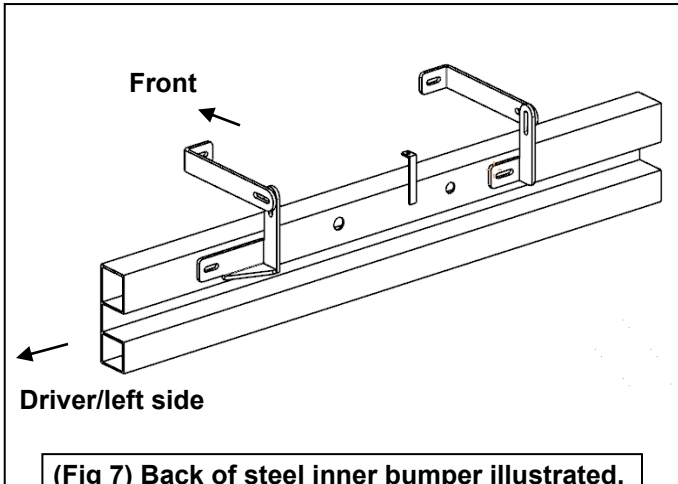

(Fig 7) Back of steel inner bumper illustrated.
NOTE: locate offset mounting holes

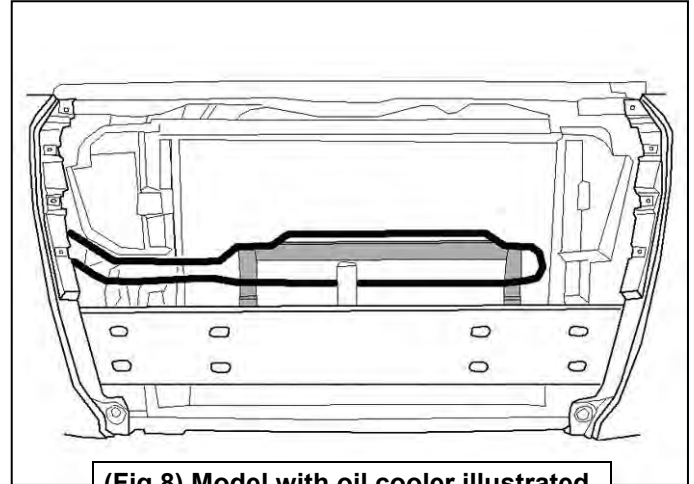

(Fig 8) Model with oil cooler illustrated

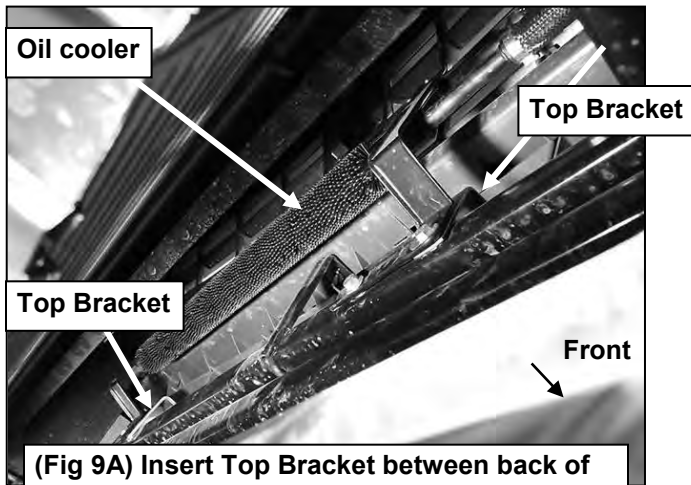

(Fig 9A) Insert Top Bracket between back of impact bumper and oil cooler bracket. Impact bumper pictured from below

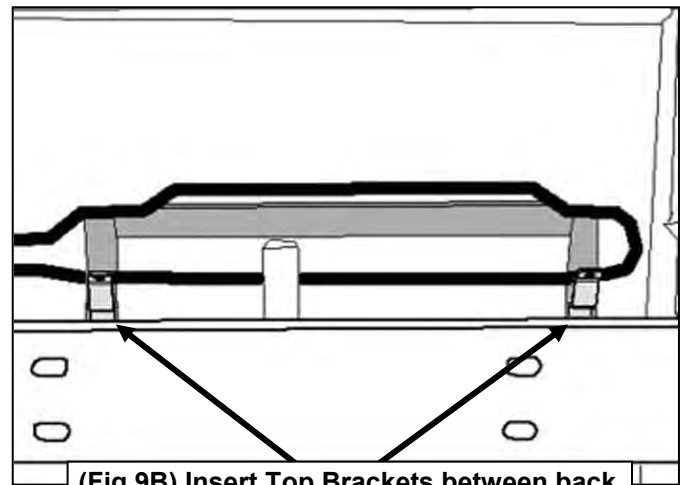

(Fig 9B) Insert Top Brackets between back of impact bumper and oil cooler brackets

- 6mm x 25mm Hex Bolt
- (2) 6mm Flat Washers
- 6mm Lock Washer
- 6mm Hex Nut

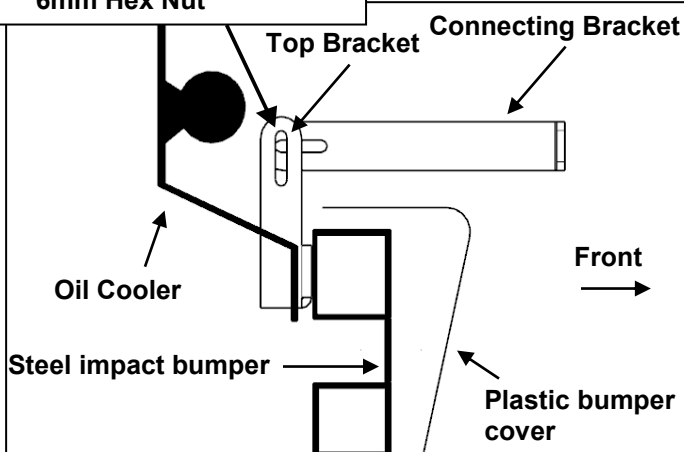

(Fig 9C) Insert Top Brackets between back of impact bumper and oil cooler brackets (side view of bumper)

- (2) 12mm x 35mm Hex Bolts
- (4) 12mm Flat Washers
- (2) 12mm Lock Washers
- (2) 12mm Hex Nuts



(Fig 10) Passenger side pictured

- (2) 6mm Button Head Bolts
- (2) 6mm Lock Washers
- (2) 6mm Flat Washers

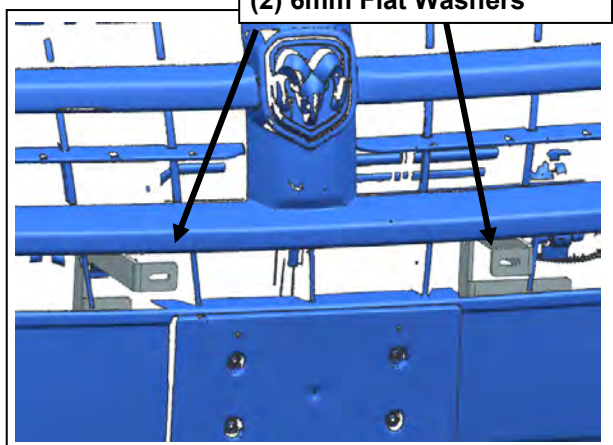

(Fig 11) Top Bracket pictured

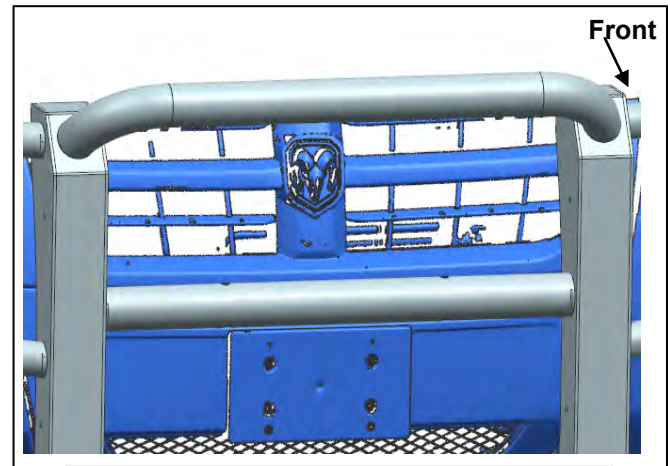

(Fig 12) Top Bracket pictured

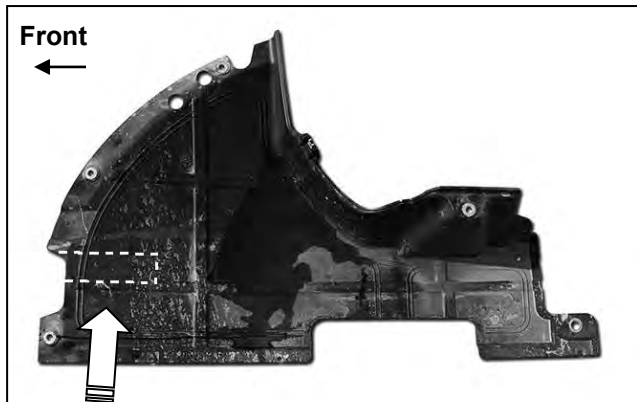

(Fig 13) Trace location of Bracket onto back of the plastic cover (dashed line). Cut as required to clear bracket