

## INSTRUCTIONS for Truck Cap RACK

**WARNING: Do NOT attempt to install or use this rack without following all instructions.**

### **SPECIFICATIONS and SAFE LOADING REQUIREMENTS**

The Model 2010-2 Truck Cap Rack is intended for use only upon pick-up truck camper shell caps that have nearly flat tops and are at least 52" long as measured along the roof from front to rear. This rack is designed to carry ladders, boats, canoes, kayaks, lumber, or other items not exceeding 250 lbs in weight. **This rack is designed to carry loads, which are spread across the width of the rack. It is not designed to carry loads where a weight of over 75 lbs. is concentrated on any space less than 12 inches wide on either crossbar or where more than 125 lbs is carried on either crossbar.** U.S. Rack does NOT warranty any automotive product and does not warranty canopies or trucks against damage caused by the weight of excessive loads being applied to them when the rack is installed on a vehicle. **U.S. Rack is not responsible for injury or property damage resulting from the rack being improperly installed or maintained.**

**BE SAFE:** The Truck Cap Rack is designed to carry cargo in a manner where the load is spread evenly between all four crossbars. All loads must be tied securely to the rack to prevent loads from vibrating or sliding forward, backward, laterally or being blown off or broken by the wind. **Carrying any load can be hazardous. U.S. Rack is not responsible for injury or property damage resulting from loads falling or being blown off a vehicle as a result of being improperly loaded or secured. Make sure all parts of all loads are securely tied down against unexpected winds, vibrations, or shock caused by road hazards such as potholes. Check daily and each time you install and/or load the rack to ensure that all nuts and bolts are tight.** Ensure that loads are not top-heavy. High loads must be transported with GREAT CAUTION to prevent loads from tipping during stops, turns, or high winds. Also **ensure that your canopy is attached to the vehicle securely**, as loads carried on the rack may increase air lift and blow the canopy off.

## INVENTORY

The Truck Cap Rack consists of **6 main parts**: A. Right Leg (x4); B. Female Crossbar (x2); C. Male Crossbar (x2); D. Left Leg (x4); and E. Cargo bumper (x4).

**Additional hardware:** 5/16-18 x 1.75" button head hex cap screws (x10); 5/16-18 nylon lock nuts (x10); 5/16-18 x 2" carriage bolts (x4); Plastic knob lock nuts (x4); black nylon washers (x10); 7/8" OD metal washers (x14); Allen wrench for 5/16-18 button head screw (x1); Small cable kit including 9' lengths of cable (x2) and 3/32" cable clamps (x4)

Fig. 1

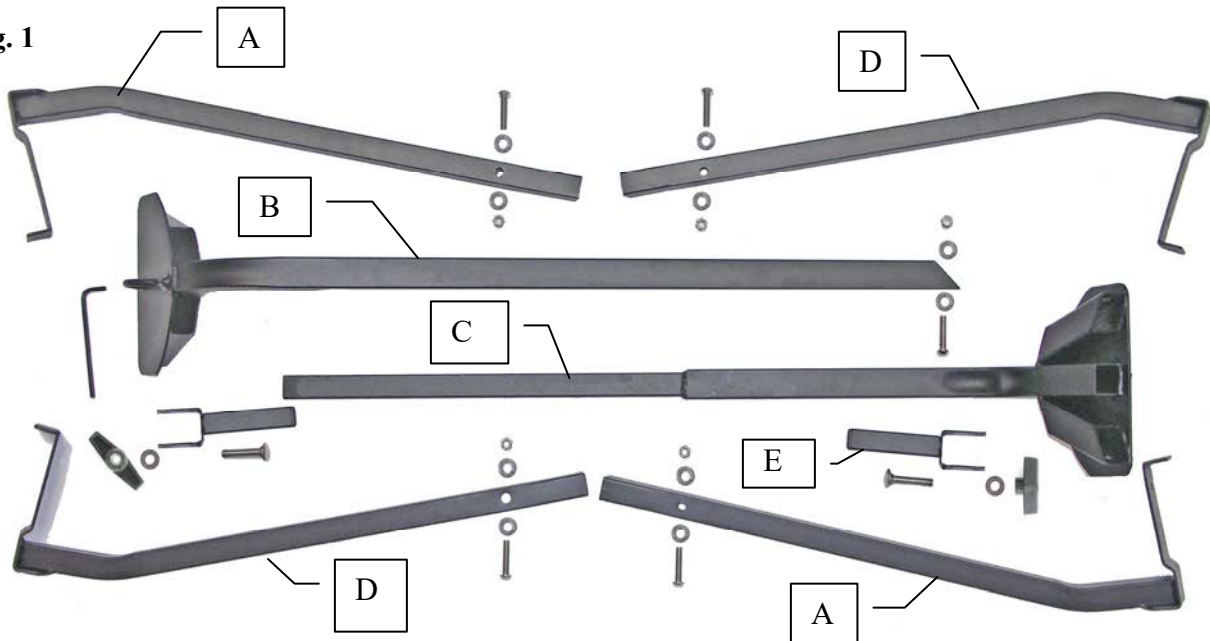

**NOTE:** Some models of trucks have wider bedrails in the front than in the back of the bed. If you received legs with feet of two different lengths, the legs with the **LONGER** feet will be mounted at the **FRONT** of the bed.

## ASSEMBLY

Read **ALL** instructions through once **BEFORE** you do anything!



**IMPORTANT:** Coat the threads of **ALL** SCREWS with a small amount of grease **BEFORE** ASSEMBLY TO MAKE ASSEMBLY EASIER AND TO HELP PREVENT THEM FROM CORRODING OR SEIZING-UP DURING ASSEMBLY AND DISASSEMBLY.

1. **Your safety is paramount.** Before assembling the rack, inventory and inspect all parts. Visually check each part to ensure it corresponds to the inventory list and check all welds for signs of cracking or weakness. If you do not have all the correct parts or if any parts appear to be defective, **STOP**. Do **NOT** install the rack.

2. **Insert the Legs (A and D) to the Crossbars (B and C).** Examine the Male and Female Crossbars. Notice that the long end of each Male Crossbar can be inserted into the long end of each Female Crossbar. Examine the Legs and notice they form pairs of left and right legs. Notice also that the top end of the Legs can insert into the short tubes welded to the inside of the Union Plate.

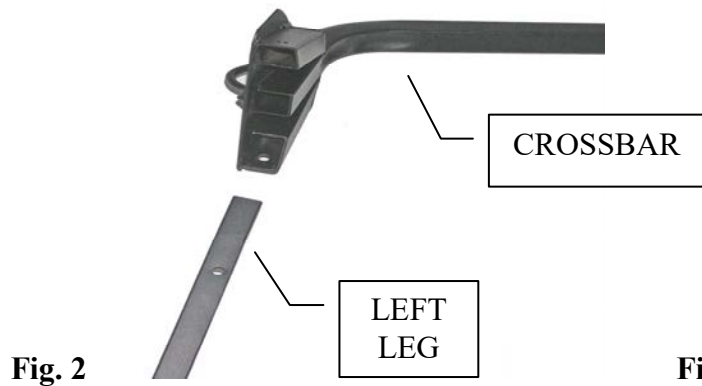

As shown in Figs. 2 and 3, insert the top of one the Left Legs into the left tube of the Union Plate, so that the holes in the top of the Leg and the Union Plate align. Place a black nylon washer onto a button-head cap screw and insert it into the hole from the outside until the end passes all the way through; then place a metal washer and a nylon lock nut on the screw and tighten firmly as shown in Fig. 4. Attach a right leg in a similar manner so that when completed, the feet should point in the same direction and should stand flat as shown in Fig. 5.

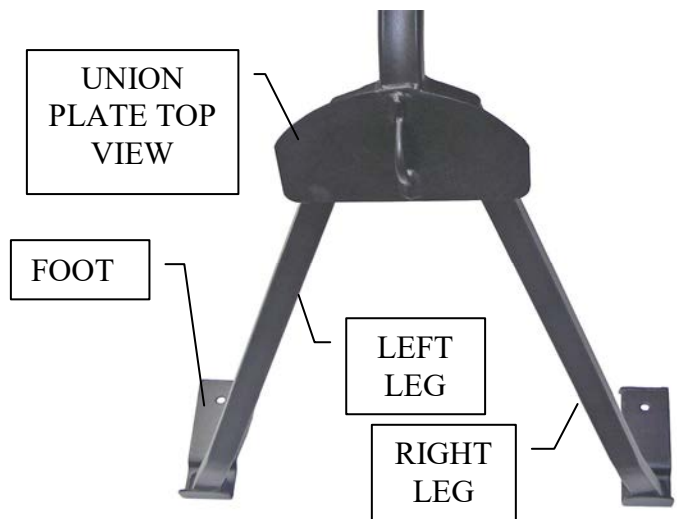
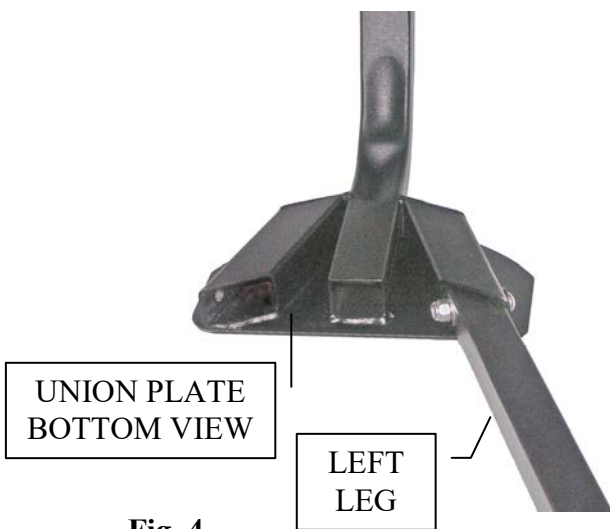

Fig. 4

Fig. 5

**3. Attach Cargo Bumpers.** The Cargo Bumper Assembly consists of the Cargo Bumper carriage bolt, a washer and a plastic locking knob. After looping the “U” around the crossbar, insert the carriage bolt down through the square hole and then through the round hole. Place the metal washer over the end of the screw and then twist on the plastic knob. Tighten as needed to prevent the cargo bumper from sliding on the bar.

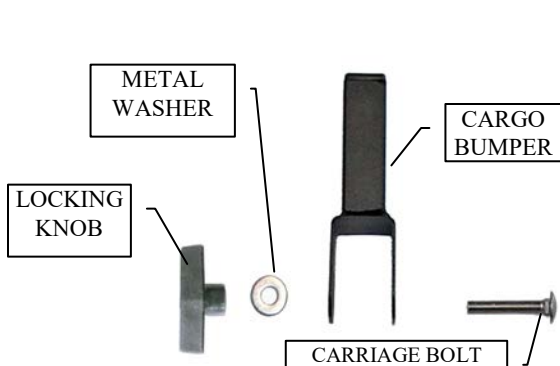
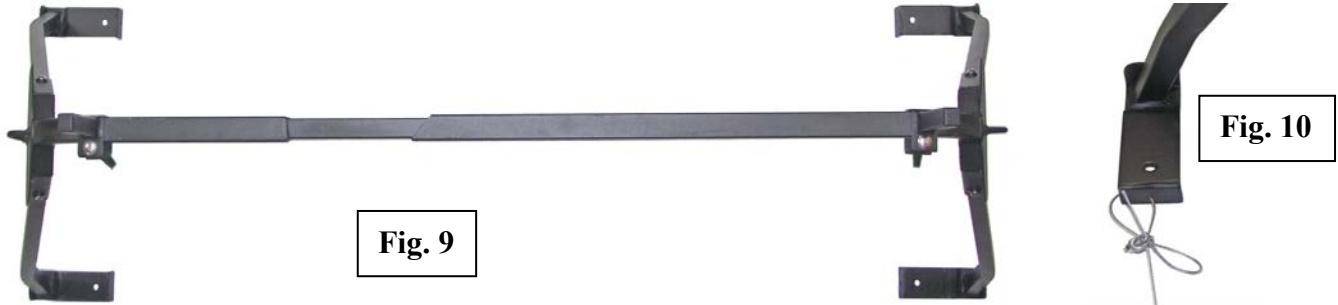

Fig. 6

Fig. 7

Fig. 8

4. **Assemble the rack.** After attaching the Legs and the Cargo Bumpers to the Crossbars, assemble the male and female crossbars together as shown in Fig. 9, below. If you do not intend to bolt the rack down to the bedrail of the truck, attach one end of the cable to one of the holes in the feet on each end of the crossbar that you have decided will be the one closest to the tailgate. Loop the cable through the hole in the end of the foot and pass it through the cable tie as shown in Fig. 10. Tighten the cable tie firmly so the cable will not slip.



## INSTALLATION

5. **Mount one side of the rack.** Loosen the clamps or screws on both sides of the truck cap. Raise one side of the cap so it is at least 1 inch above the bedrail. Insert a wooden block or other object to keep the cap elevated as shown in Fig. 11. Disassemble each section of the rack into two sections. Pick up the female side of the rack and slide the feet under the cap and place them on the truck bedrail near the tailgate. Ensure that both feet are sitting firmly on the bedrail in front of the tailgate, that the lip at the end of each foot had slid down over the inside lip of the bedrail, and that the loose end of the cable is on the inside of the truck bed. If you were to look at the foot on the bedrail without the cap on the truck, it should be positioned as in Fig. 12. You may lower the cap onto the feet as shown in Fig. 13 or you may elevate the front portion of the cap and install the female side of the front portion of the rack on the bedrail.



6. **Mount other side of the rack.** Raise the other side of cap and slide the male side of the rack onto the bedrail, except that when you slide the feet under the cap, simultaneously feed the male end of the crossbar into the female side of the rack. When completed the other set of feet should appear as in figure 14 and the crossbar should appear above the cap as shown in figure 15.





7. **Bolting together the male and female sides of Crossbar.** When connecting the male and female parts of the crossbar, note that the female side has a pre-drilled hole near the end. Also notice that the end of the female tube is cut at an angle so that when the fastener is applied it firmly draws the male tube against the inside wall of the female to reduce rattle. After the rack has been properly positioned on the bedrails on both sides pull the two sides together gently and push down with moderate force to take any slack out of the assembly. This force should be enough to take out the slack but not so much that it forces the rack against the sides of the cap or pulls the feet away from the bedrail. After the slack has been removed, make a mark on the male crossbar through the hole in the female crossbar. Using an electric drill, make a hole straight through the male crossbar at the mark as shown in Fig. 18.

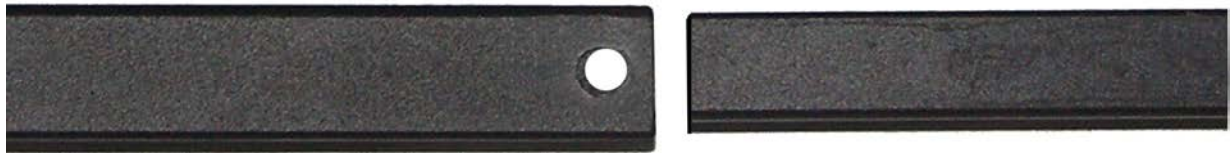

Fig.16

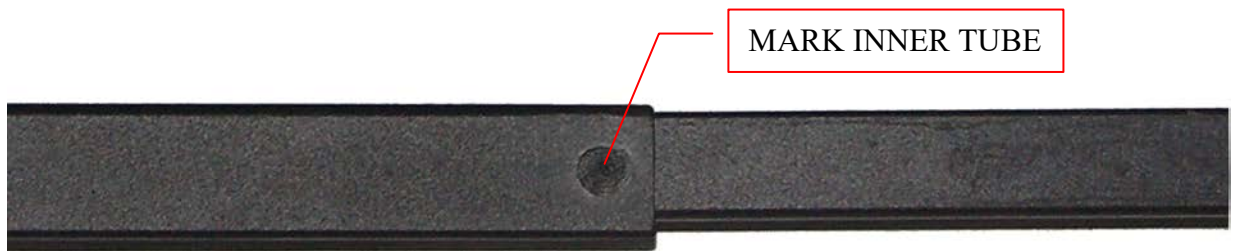

Fig. 17

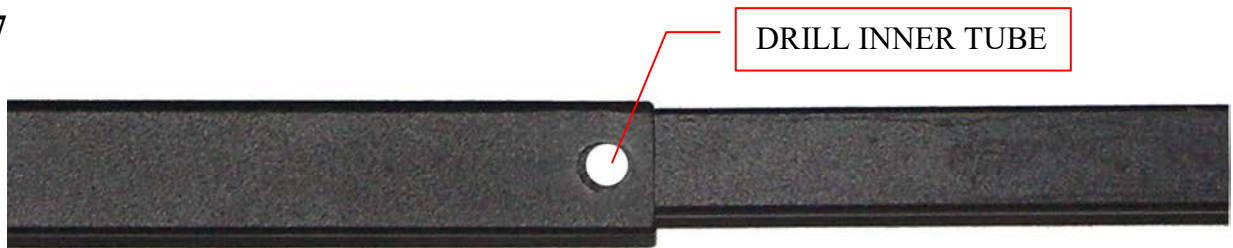

Fig. 18

Place a nylon washer on the head of a button-head cap screw and insert it through the hole. Place a metal washer and nylon lock nut on the other end. Tighten firmly as shown in Figs. 19 and 20.



Fig. 19



Fig. 20

8. **Secure Rack.** After installing the rack, position the camper shell clamps so that they are between the feet of each section of the rack and tighten securely so that the rack cannot move. Note that there is a hole in the top and the front of each foot of the rack. After assembling the rack, take the loose ends of the cables and pass them through the OEM tie-down at the front of the bed or some other secure anchor and attach securely using a cable tie as shown in Fig. 21. Ensure that the slack is taken out of the cable and that it is tight enough, so that even if the cap were to become loose, the rack could not possibly vibrate free and slide off the back end of the truck.

Remember that the attachment of the rack to the bed is only as strong as the attachment of the cap to the truck bedrail. Each time before you use the rack, ensure that all fasteners are tight and that each section of the rack is properly seated between the top of the bedrail and the bottom of the cap.

Frequently check during use to ensure that all rack fasteners as well clamps or screws holding down the cap remain tight. When properly installed your rack should appear as in Fig. 22 and provide you excellent service in hauling up to 250 lbs. of cargo

9. **Permanent Mounting.** For permanently mounting the rack to a truck with metal bedrails it is possible to attach the feet by drilling through the top or the lip of the bedrail and securing with screws and nuts. An OPTIONAL hardware kit is available for this purpose. Install screws firmly with the head on the outside and a washer and nylon locknut on the under or back side.



Fig. 21



Fig. 22