

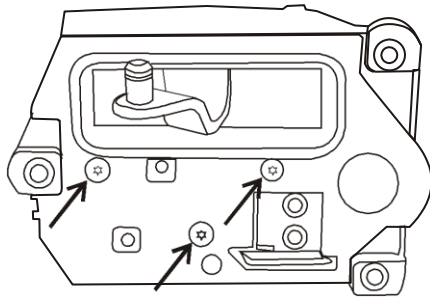

Mercedes W215/220 Shift Lever Repair Kit*

Standard factory workshop manuals and procedures should be followed to R&R the shifter assembly facilitating this repair.

Step 1 – Remove base plate attached by (3) T25 Torx screws.



Step 2 – Remove outer aluminum cover attached by (3) T20 Torx screws.

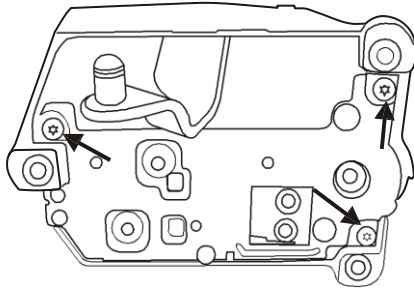

Step 3 – Remove upper shift cover (steel) attached by (2) T10 & T20 Torx screws.

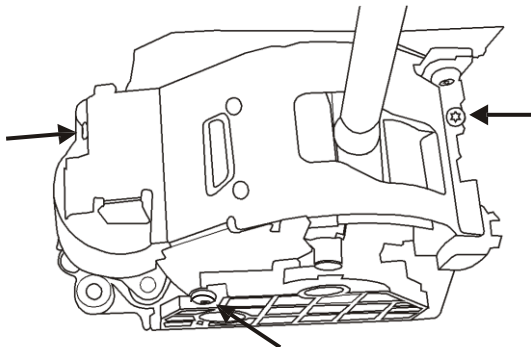

Step 4 – Remove plastic side cover attached by (3) T20 Torx screws. Note: Broken plastic shift lever pieces should be visible; remove all loose pieces and discard.

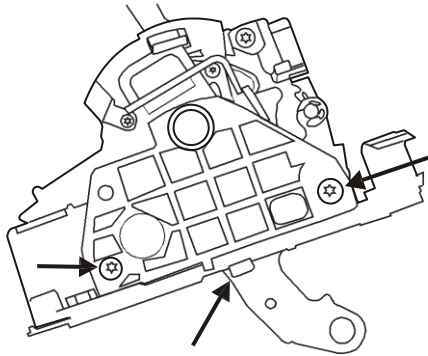

Step 5 – Remove park solenoid attached by (2) T25 Torx screws. Note: Two rivets may require drilling out in some instances; new ones are supplied in kit.

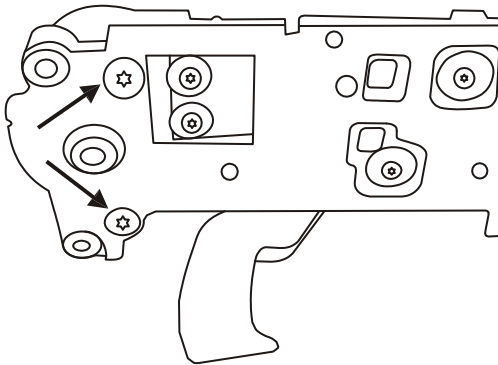

Step 6 – Using a suitable drift, remove fulcrum pin on remaining piece of broken plastic shift lever.

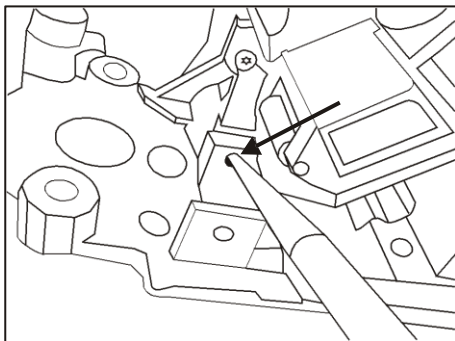

Step 7 – Swap spring from plastic lever to new aluminum lever; may require gentle twisting to remove and install.



Step 8 – Reinstall new lever and reverse all procedures to reassemble shifter. Reinstall repaired shifter assembly per factory workshop manual following all procedures.

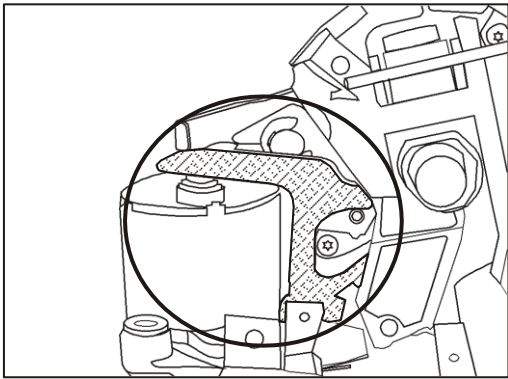

*Note: there are 2 styles of shift park levers which are differentiated by the width of the hinge pivot base. Either a 5mm or an 11mm base may be fitted. This is a running change and not defined by a specific year or chassis. A quick inspection of the existing plastic lever in the shifter may be required before ordering the correct part.