



# AIR DITCHER

AIR TO COIL CONVERSION KIT

## 1990-2002 Lincoln Towncar



This product is intended to modify your vehicle and replace the existing air controlled suspension components with a passive coil and shock system. The system has been designed and extensively tested to provide the same ride quality and height as the O.E.M. system.



This conversion kit requires the removal of the stock coil spring, which may be under compression. Proper procedure must be followed to minimize risk of personal injury and product damage.

### General Precautions

When servicing any vehicle be sure to follow all safety procedures.

First, make sure that when lifting the vehicle that you are using the appropriate jack for the weight of the vehicle.

Make sure before going underneath any vehicle that it is properly supported with sturdy jack stands and on level ground so that the vehicle doesn't fall or slide off of the jack and onto you.

As with any automotive repair, make sure you have the appropriate tools to do the job so you don't damage any parts on the vehicle. There is a list of tools needed included in these instructions.

Safety glasses and mechanic gloves should also be worn for your protection.

Be sure to follow the instructions in the order that they are given. The instructions are in a certain order for a reason and improper installation could lead to damage to your vehicle or the parts. Keep in mind that if you damage the parts during installation you will be responsible for the replacement parts.

### Included In This Conversion Kit



### Minimum Tools Needed For This Installation



Metric Hand Tools (Sockets/Wrenches)



Jack and Jackstands



Wire Cutters



## WARNING

Our complete strut assemblies are completely assembled from the factory. These units contain a coil spring under compression. DO NOT ever loosen the top mount main bolt for prevention of both physical harm and vehicle damage.

## CAUTION

To avoid injury you MUST turn the air suspension service switch to the OFF position. This switch is located in the trunk on the left hand side in front of the left taillight.

# Removal (Coil Spring)

1. Position a hoist under the rear axle housing,  
Place jackstands under frame side rails.
2. Remove rear stabilizer bar.
3. Disconnect the lower studs of the two shock absorbers from the mounting brackets on the rear axle assembly.
4. Unsnap the parking brake rear cable and conduit from upper arm retainer before lowering the rear axle housing.
5. Lower the hoist and axle housing until the rear springs are released.
6. Remove rear spring and rear spring center mounting

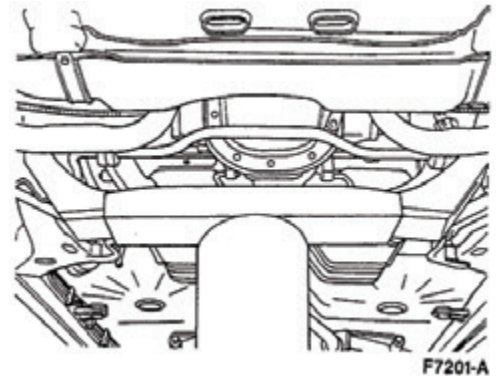

# Removal (Shock)

1. For shock absorbers using a plastic dust tube, place an open end wrench on the hex stamped into the dust tube's metal cap. For shock absorbers with a steel dust tube, simply grasp the tube to prevent stud rotation when loosening the retaining nut.

3. Remove the shock absorber retaining nut, washer, and insulator assembly from the stud on the upper side of the frame. Compress the shock absorber to clear the hole in the frame

4. Remove the self-locking retaining nut and disconnect the shock absorber lower stud from the mounting bracket on the rear axle tube.

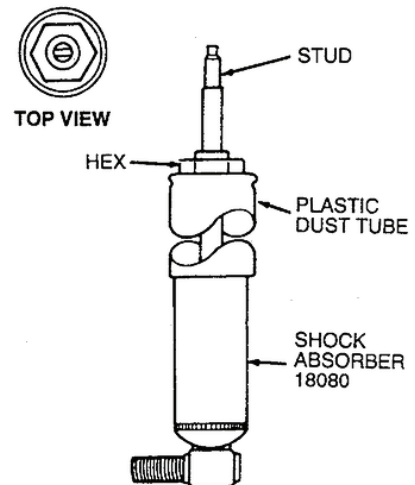

## Torque Specifications

Wheel Lug Nut.....	98 ft. lbs
Strut (Knuckle) Mounting Nut.....	81 ft. lbs.
Strut (Tower) Mounting Nut .....	48 ft. lbs.

# Suspension Light Disable

1. Find the air suspension module located behind the glovebox on the right side of the vehicle.

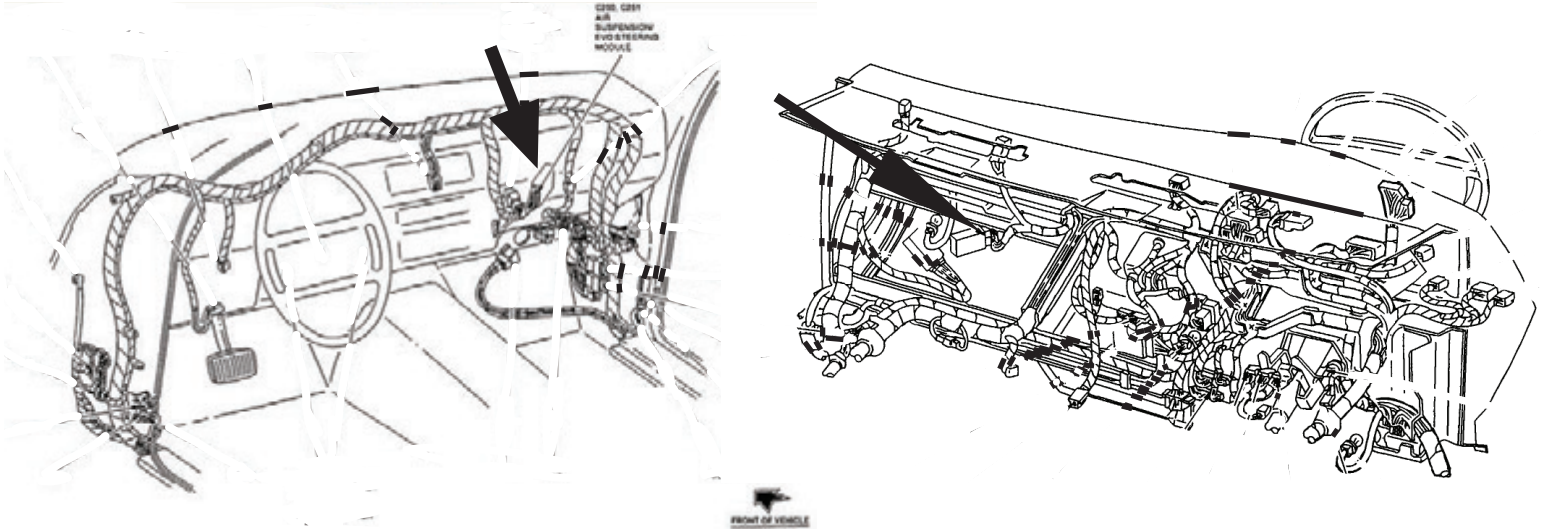

2. Behind the glove box, mounted to the heater plenum is a connection with two plugs, one GRAY, one BLACK, or both GRAY, each about 2". On the BLACK or TOP connector, midway, is a DARK GREEN/LIGHT GREEN wire (this is pin #11). Cut this wire to disable the "Check Air Suspension" light. Cut as far from the plug as you can should it ever need to be reconnected/spliced. Reattach the glove box.

