

UNDERCOVER LED KIT USER MANUAL

CONTENTS

6LED KIT
w/ Split Color

LIGHTHEAD x 2pcs



EXTENSION CABLE



FLASHER & CABLE



FLANGE OPTION x 2pcs



LIGHT ASSEMBLY INSTALLATION

1. Remove the Corner/Head/Tail light from vehicle.
2. Select location to mount lighthouse.
3. Drill 1 inch diameter hole to the light assembly.
4. Insert lighthouse into hole.
5. Apply silicone (user-supplied) for better fit.

WARNING: Do NOT cover heat sink with silicone. It may cause damage to the product and void warranty.

OPERATIONS

To +VDC (fuse @2A) for Color1 activation.....**RED**

To Chassis Ground.....**BLACK**

To +VDC (fuse @2A) for Color2 activation.....**WHITE**

For Synchronization & Flash Patterns.....**YELLOW**

Connect YELLOW wires of all Kits together for synchronization

*All kits must be set at the same pattern

For Simultaneous or Split Flash (single head):

1. Apply +VDC to RED and YELLOW wires simultaneously to enter Mode selection; lighthouse will display single flash.
2. Remove YELLOW wire from +VDC and momentarily apply to +VDC to change Mode: Mode1 = Simultaneous Flash, Color1 and Color2 LEDs flash together.
(default)
Mode2 = Split Flash, Color1 LEDs alternate with Color2 LEDs.

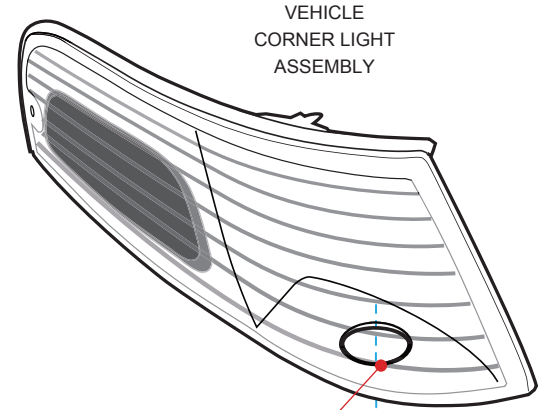

1 inch dia. hole

Lighthouse

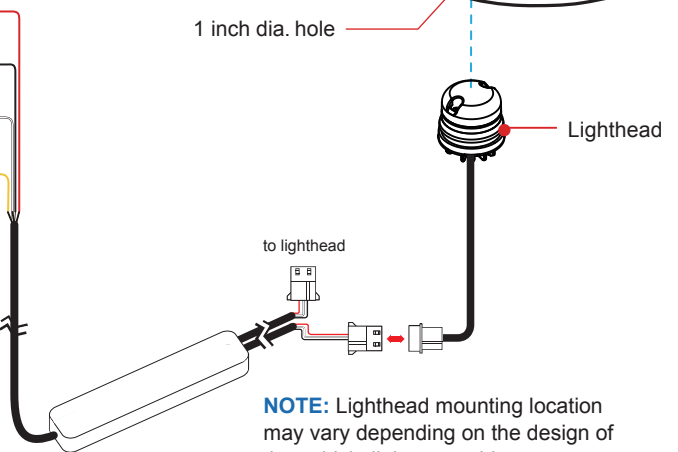

NOTE: Lighthouse mounting location may vary depending on the design of the vehicle light assembly.

Mode1 (Simultaneous Flash) (Suitable for Single-Color Heads)		Flash	Head1	Head2
			Color1 Color2	Color1 Color2
Flash Patterns #1~9	Color1 & 2 flash together, Head1 alternate Head2	1st	on on	off off
		2nd	off off	on on
Flash Patterns #10~17	Color1 & 2 flash together, Head1 & 2 flash together	1st	on on	on on
		2nd	off off	off off
Flash Pattern #18	Steady Half	1st	on on	on on
		2nd	on on	off off

Mode2 (Split Flash) (Suitable for Split-Color Heads)		Flash	Head1	Head2
			Color1 Color2	Color1 Color2
Flash Patterns #1~9	Color1 alternate Color2	1st	on off	off on
		2nd	off on	on off
Flash Patterns #10~17	Color1 flash together, Color2 flash together	1st	on off	on off
		2nd	off on	off on
Flash Pattern #18	Steady Half	1st	on on	on on
		2nd	on off	on off

For Flash Pattern change, momentarily apply +VDC to **YELLOW** wire: · once for next pattern · quickly three times for reset

Flash Patterns			
1	Random	11	Double (all)
2	Single (split)	12	Quad (all)
3	Double (split)	13	Quint (all)
4	Quad (split)	14	Mega (all)
5	Quint (split)	15	Ultra (all)
6	Mega (split)	16	Single-Quad (all)
7	Ultra (split)	17	Single H/L (all)
8	Single-Quad (split)	18	Steady Half
9	Single H/L (split)	19	Steady All
10	Single (all)		

NOTE: This unit may not be factory set at FP# 1.

FLANGE MOUNT INSTALLATION (for kits with Flange option only)

1. Remove Original Base Plate from lighthead base.

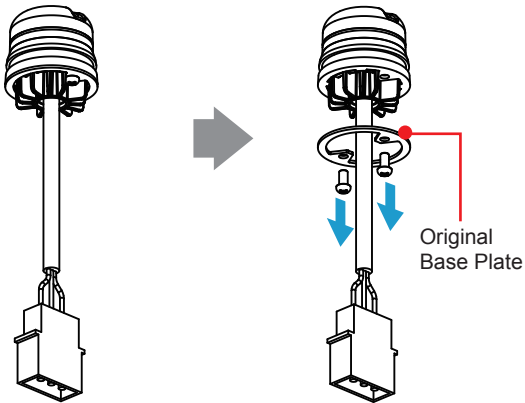

2. Secure Flange Plate to lighthead base with screws.

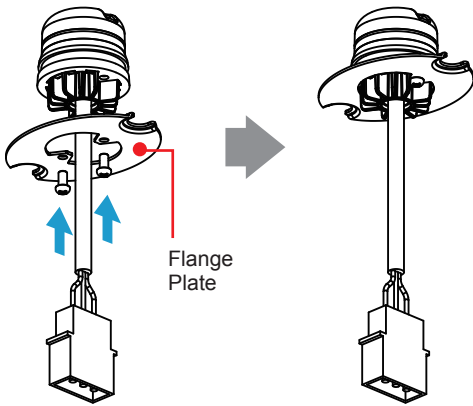

3. Use mounting flange to mark wire and screws holes.
4. Drill marked holes accordingly.
5. Insert lighthead pigtail into wire hole.
6. Place foam, lighthead, and flange in line with the mounting holes, and secure with supplied sheet metal screws.

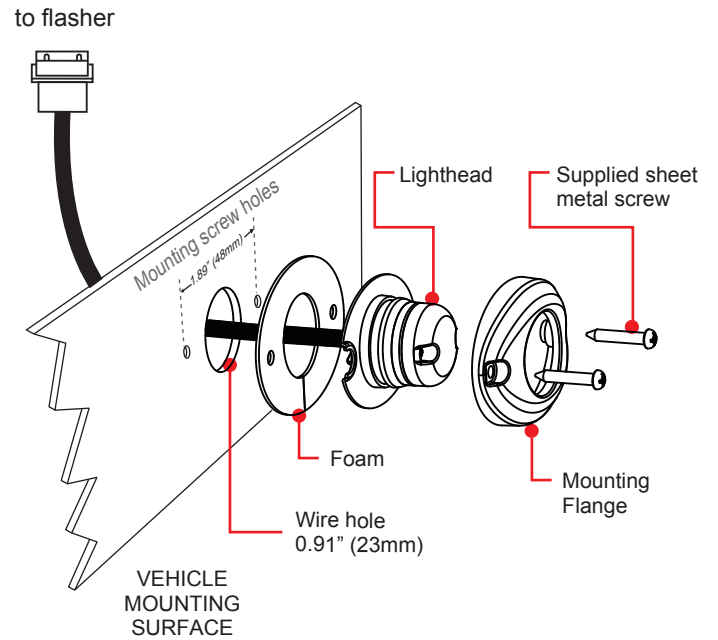

WARNING: Make sure to use the foams when mounting lighthead.

WIRING TO EXISTING STROBE CABLES

In this configuration, existing strobe extension cables are used to facilitate installation.

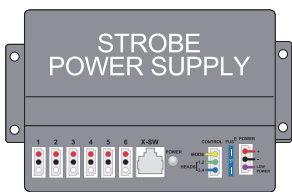

1. Disconnect strobe extension cables from strobe power supply.

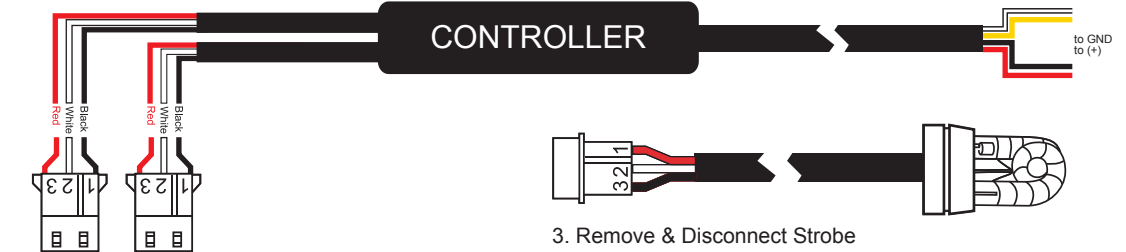

2. Connect LED Kit connectors to strobe extension cables.

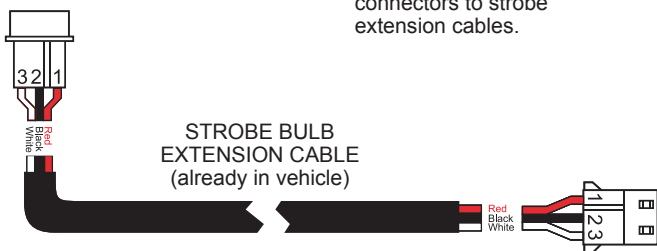

NOTE: Wire colors of LED Kit do not need to match wire colors of extension cables.



3. Remove & Disconnect Strobe bulbs from extension cables.



4. Insert & Connect LED Lighthead to strobe extension cables.

WARNING: Do not connect LED lighthead directly to strobe power supply. It will cause damage and void the warranty.