

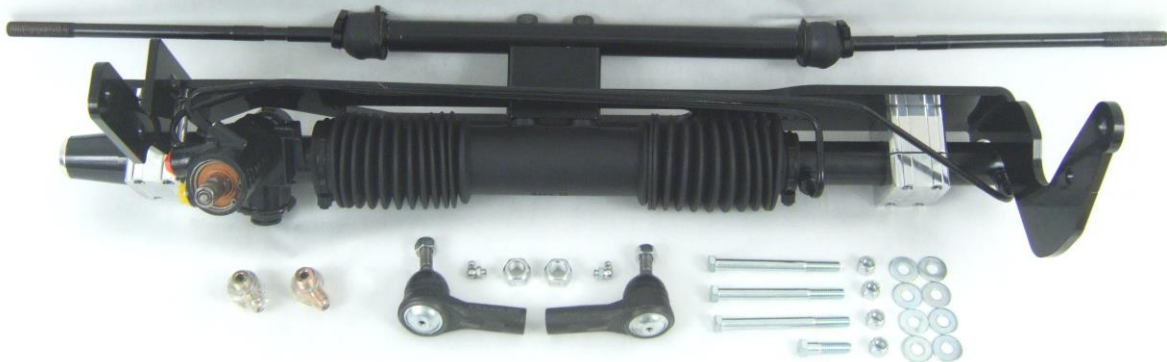

'63-'82 Corvette Power Rack & Pinion Kit Instructions

8011540

Unisteer offers a limited warranty against all manufacturer defects of their kits and supplied parts. Unisteer will not honor any warranty on any parts that have been modified or improperly installed. Full refund will NOT be granted to any kits that are damaged, scratched, or altered in any fashion. Unisteer will not reimburse any labor money to the customer to change out the part even under a warranty repair.



***USE ONLY POWER STEERING FLUID IN SYSTEM. DO NOT USE ATF.**

***ALTHOUGH THIS KIT IS FAIRLY SIMPLE TO INSTALL, SOME MODIFICATIONS MAYBE NECESSARY.**

***BEFORE STARTING INSTALLATION, PLEASE BE AWARE OF THE MODIFICATIONS THAT ARE NEEDED TO INSTALL.**

***ALSO BE AWARE THAT THERE ARE APPLICATION/PROVISIONS NEEDED IN ORDER TO INSTALL. PLEASE READ ALL INSTRUCTIONS FIRST.**

***DUE TO VARIABLES OUTSIDE OUR CONTROL THESE KITS MAY NOT FIT ALL APPLICATIONS. ALSO, PLEASE VERIFY KIT WILL FIT YOUR APPLICATION BEFORE ALTERING VEHICLE.**

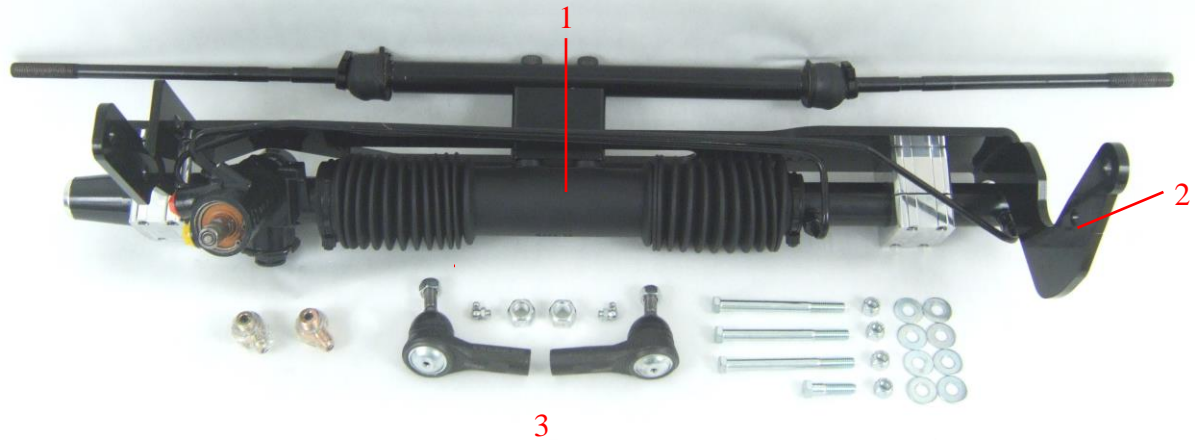

KIT CONTENTS:

#	Part Number	Description	Qty	Inspected By / Date
1	8011580	Power Rack & Pinion	1	
2	8025700	Mounting Bracket	1	
3	621930	Install Kit	1	
	--120230	- Jam Nut	2	
	--120490	- 3/8" -16 Lock Nut	4	
	--200990	- 3/8" x 1" Washer	8	
	--231490	- 3/8" -16 x 1 1/2" Hex Bolt	1	
	--231490	- 3/8" -16 x 4 1/4" Bolt	3	
	--8020940	- Outer Ends	2	

1963-1982 Corvette Rack and Pinion Installation

1. Perform the directions in the shaft kit first then move onto step 2 here.
2. From under the vehicle, install the new rack and pinion assembly between the frame rails. Fasten the rack bracket to the chassis using the supplied 3/8" bolts. Driver side uses 2 long bolts and passenger side uses 1 long and 1 short. Short bolt goes into the top hole in the bracket. Torque bolts to 45 ft lbs.

Note: Make sure rack bracket is perpendicular to the ground.

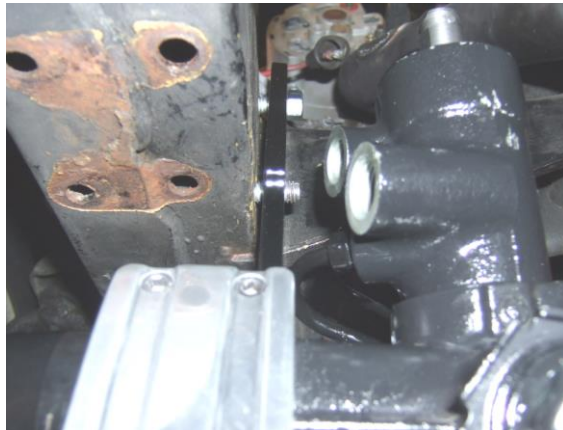

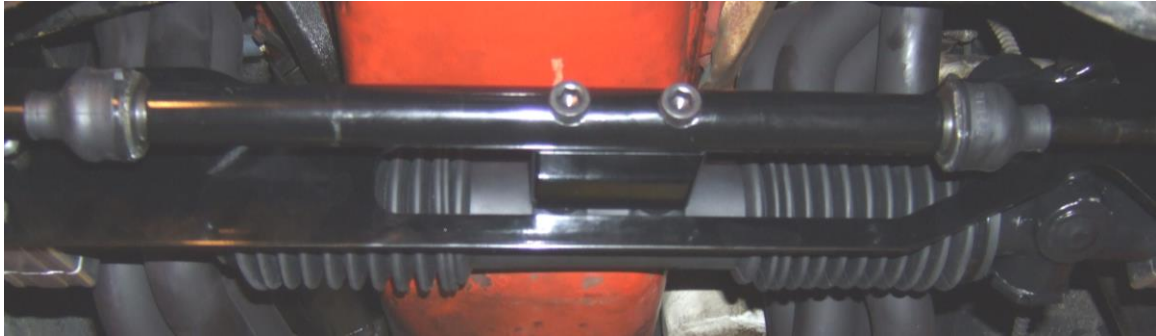
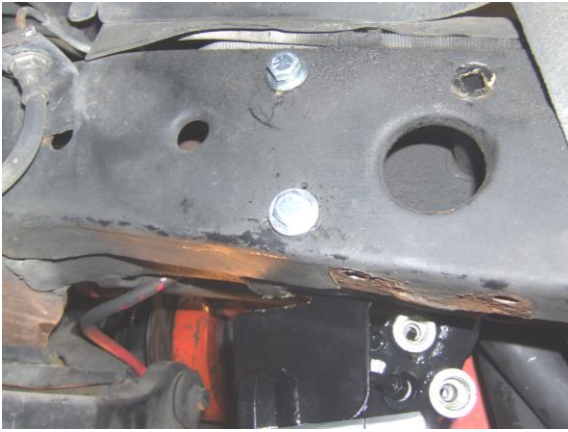

3. Thread lock nuts and tie rod ends onto the inner tie rods.



4. Fasten tie rod ends to spindles and tighten locking nuts to 50 ft lbs.

5. Tighten all pinch bolts on u=joints to 45 ft lbs.



Note: For Steering Pump 8061080 & 8061090 Instructions, consult manual 657440.

Note: For Shaft Kit 8052090 Instructions, consult manual 656260

Note: For Shaft Kit 8052080 & 8052110 Instructions, consult manual 656270

1963-1982 Corvette Final Steps

6. Top off power steering fluid level in pump reservoir.
7. Start the car and let idle for 10 seconds, "do not turn wheel during this period". Turn off vehicle. Top off power steering fluid. Restart car, turn wheel slowly, lock to lock. Check fluid once more, top off if needed.
8. Vehicle will need to be aligned properly after install.

UNISTEER® *Performance Products*

No part of these materials can be reproduced or utilized in any form or by any means, electronic or mechanical, including photocopying, recording or by any information storage and retrieval system, without permission in writing from Maval Manufacturing Corporation.