

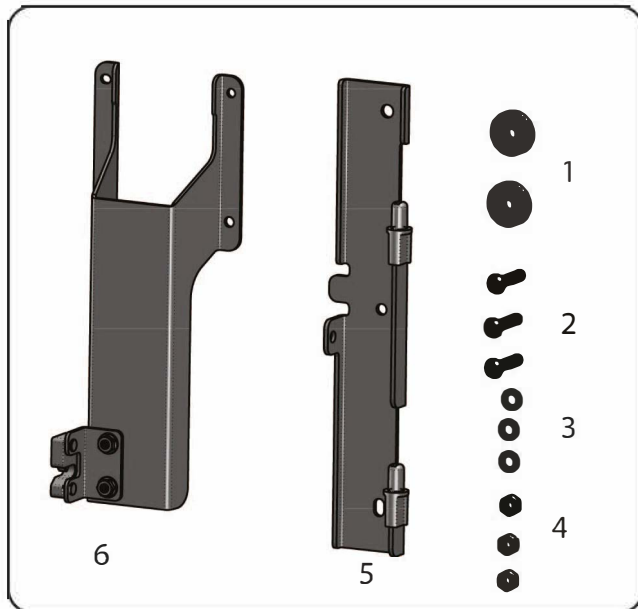

Installation Guide

SC203P - Passenger Side Ford F150 2015



Hardware Included

1. Aluminum Spacers (qty 2)
2. Torx Bolts T40 (qty 3)
3. Lock Washers (qty 3)
4. Assembly Nuts 1/2 Hex" (qty 3)
5. Truck Bracket (qt 1)
6. Striker Bracket (qty 1)

TRUCK BRACKET INSTALLATION - Remove the tailight by removing the two(2) 8mm hex bolts and pulling the tailight towards the rear of the truck. Remove the wiring harness connector. Set tailight to side.

1. **TRUCK BRACKET INSTALLATION (figure 1)**- Line up the truck bracket according to the drawing.

2. **TRUCK BRACKET INSTALLATION (figure 2)** - Attach the bracket to the truck. Starting with the middle hole, insert a

torx bolt through the truck bracket and the truck, place lock washer and assembly nut on bolt and hand tighten only. Use a torx bolt on the top hole followed by an alluminum spacer, lock washer and assembly nut (Note: the spacer should be positioned with the grooves against the truck bed). Do not tighten at this time. Repeat this procedured for the bottom hole and tighten all three.

3. **STRIKER BRACKET INSTALLATION (figure 3)** - Remove the four(4) T30 torx bolts from the Box Link plate. Using the existing hardware, install the striker bracket over the top of the Box Link plate (Note: The tie down can remain attached to the plate). Reinstall the tailight.

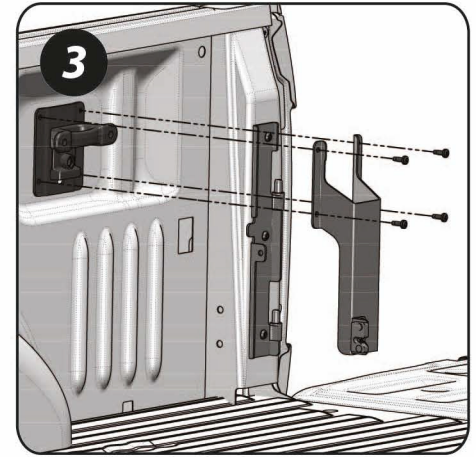
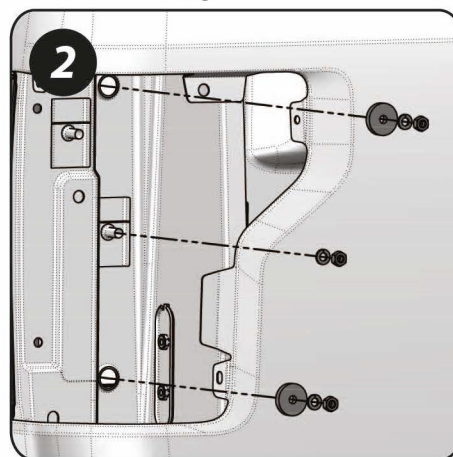
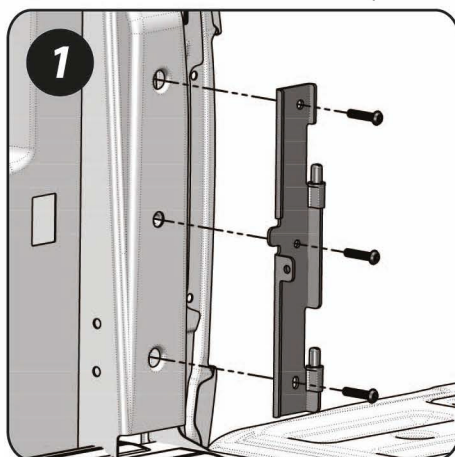



Installation Guide - Continued

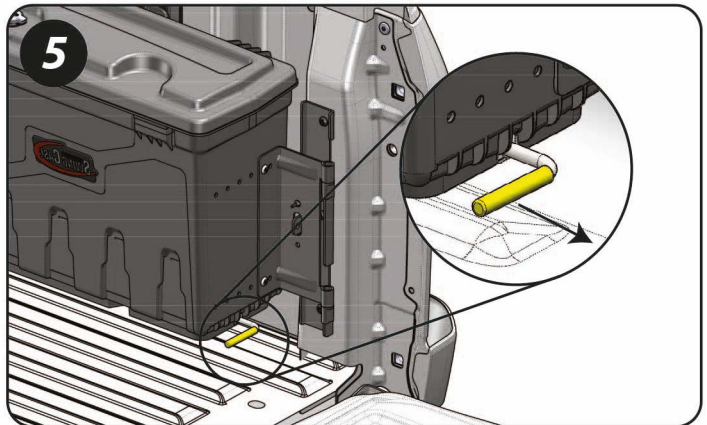
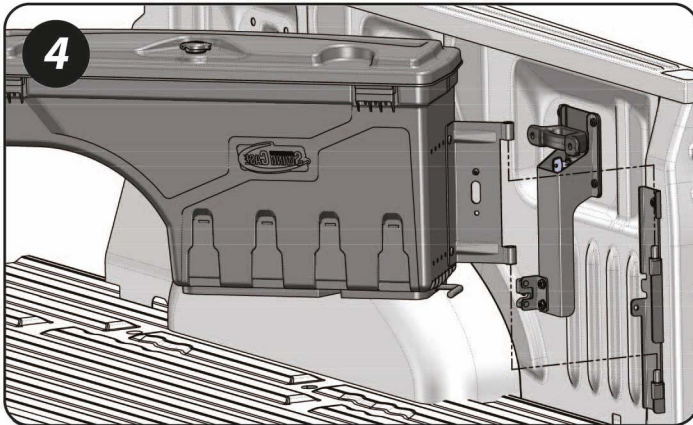

4. INSTALLING SWING CASE

Lower the box onto the hinge pins and gently push the box to the stowed position.

5. OPERATION AND ADJUSTMENT

Pull the latch rod and swing through the full motion making sure it operates freely and latches easily. Do not slam the box to stow it, if it will not latch easily it may be necessary to make some minor adjustments. The latch has slotted holes, just loosen the two bolts and adjust as needed.

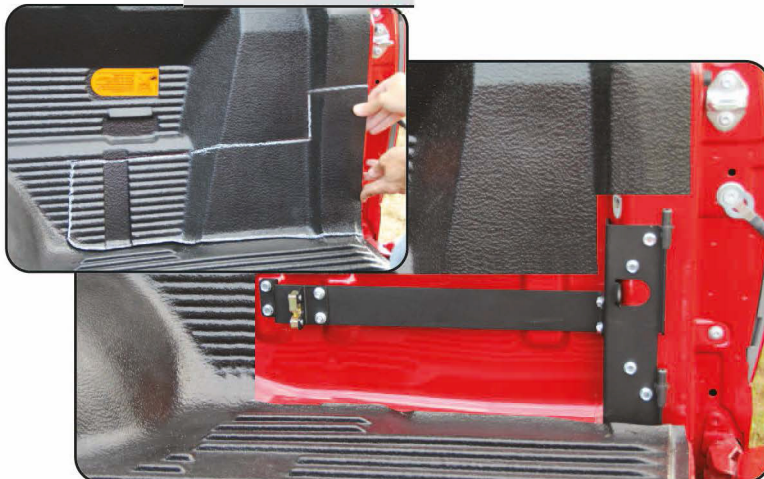

• FOR TRUCKS WITH PLASTIC BED LINERS

For trucks with plastic bed liners it will be necessary to trim the liner. **DO NOT INSTALL THE BRACKETS ON TOP OF THE BEDLINER.** The brackets will not fit over the plastic bedliner, the brackets must be attached directly to the sheet metal. Hold the brackets up against the bedliner in their approximate location. Using a grease pencil, mark lines to indicate where to cut the bedliner. Once you have finished trimming your bedliner, install the brackets per the instructions in Steps 1 through 5. Due to the fact that all the brands of bed liners fit differently we can not provide exact instructions as how much of your liner to trim. These pictures are only an example and may not accurately depict your specific situation.

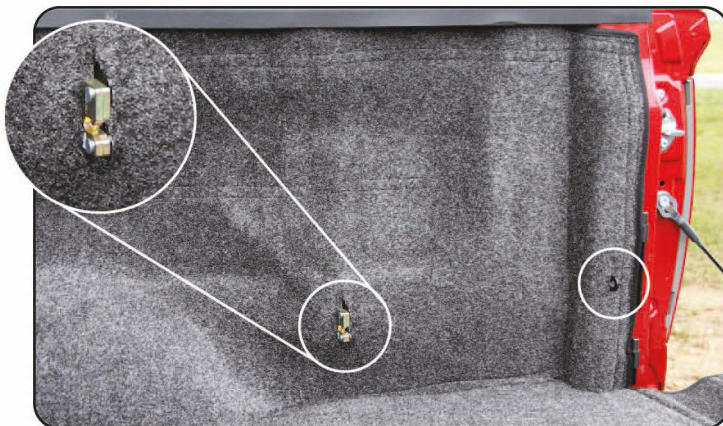

• FOR TRUCKS WITH BED RUGS

For trucks with Bed Rugs it will be necessary to cut slots in the material. **WE DO NOT RECOMMENDED TO INSTALL THE BRACKETS ON TOP OF THE BED RUG.** Most of the brackets will fit under the bed rug, pull the Bed Rug loose from the corner, remove any hook and loop strips that may be in the way of the brackets, and install the brackets per instructions in Steps 1 through 5. Push the rug around the latch bracket and cut a slot to allow it to stick through. Push the rug around the pad lock piece and cut a slot to allow it to stick through. It may be necessary to remove the rubber bumper from the bracket assembly. You will need to re-attach the Bed Rug to the truck bracket at the light well using the existing hook and loop strips.