

Caliper Numbering and Boxing Guidelines

All *UCX* caliper part numbers conform to the following standard:

- Last digit even (0,2,4,...) - Left or Driver Side caliper (see exceptions below).
- Last digit odd (1,3,5,...) - Right or Passenger Side caliper (see exceptions below).
- All caliper part numbers have a "10-" prefix.
- All unloaded calipers have four (4) numeric digits.
- All semi-loaded part numbers are the unloaded number with an "S" suffix.
- All loaded single part numbers have five (5) numeric digits comprised of a leading number (either "1" or "2") followed by the four digit unloaded number.
- All loaded set part numbers have six (6) numeric digits comprised of the four digit left unloaded number followed by the last two digits of the right unloaded number

These standards are based on the most common caliper design of left and right calipers being mirror images of each other (exceptions to this design are described below). In this design, determining if a caliper is left or right depends on how the OEM mounted the caliper on the rotor. There are two possible mounting positions: Rear Mount and Front Mount (see illustrations below). In both cases the caliper bleeder screw must be situated in the up position on the rotor with the hydraulic chamber facing the engine (if the caliper is mounted with the bleeder down, you cannot bleed the air out of the system). *UCX* strongly recommends that calipers be replaced in pairs. However, if you are replacing only one caliper, you must know the mounting position to determine right and left.

Exceptions to the Mirror Image Caliper design:

- In some instances, the OEM will mount the caliper on the rear rotor edge on one model and the front rotor edge on another model. In this case, *UCX* will box it based on the most common mounting position. For those models using the less common mounting position, *UCX* will reverse the numbers in the catalog.
- In some instances, the caliper is "universal". This means that the design is such that the caliper can be mounted either on the left or right. This caliper design takes two forms:
 - The casting has identical bleeder and hose holes drilled on opposite ends of the caliper. In this case *UCX* ships the bleeder loose in the box and the technician installs the bleeder in the correct hole depending on which wheel is being serviced.
 - The caliper mounts on the front rotor edge on one side of the vehicle and on the rear rotor edge on the other side of the vehicle. In this case the same caliper is used on both sides of the vehicle.On "universal" calipers, *UCX* will show the same part number for both left and right in the catalog.

Front Mount Caliper

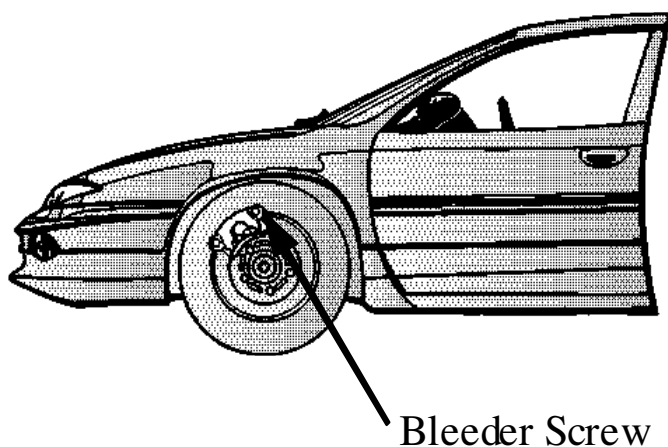

Rear Mount Caliper

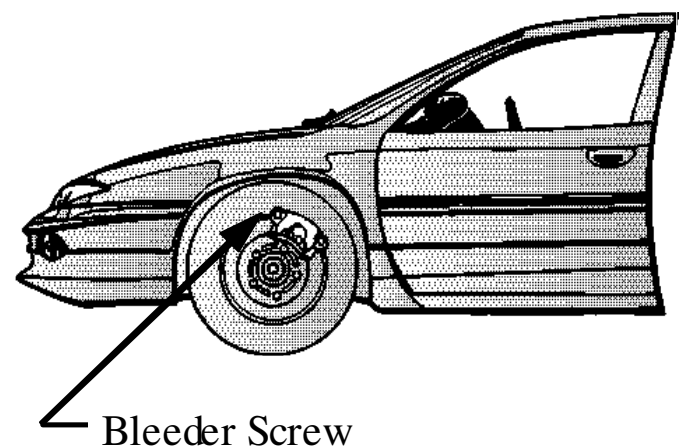



UCX Caliper Numbering and Boxing Guidelines (cont)

To help insure proper boxing and control warranty, *UCX* includes certain information on the box label. As described on the previous page, in most cases, all even numbered parts are left/drivers side and odd numbered parts are right/passenger side. To get the proper caliper in the box, you must know rotor mounting position and bleeder location. *UCX* has developed a boxing indicator for each part number that can be used to quickly determine what caliper goes in what box. (see Box Indicator Example below). A counter person can quickly check a mis-box warranty by referring to this indicator. A Lot # and Production Code are also included on the label to allow *UCX* to track and correct warranty problems when they occur (see descriptions below).

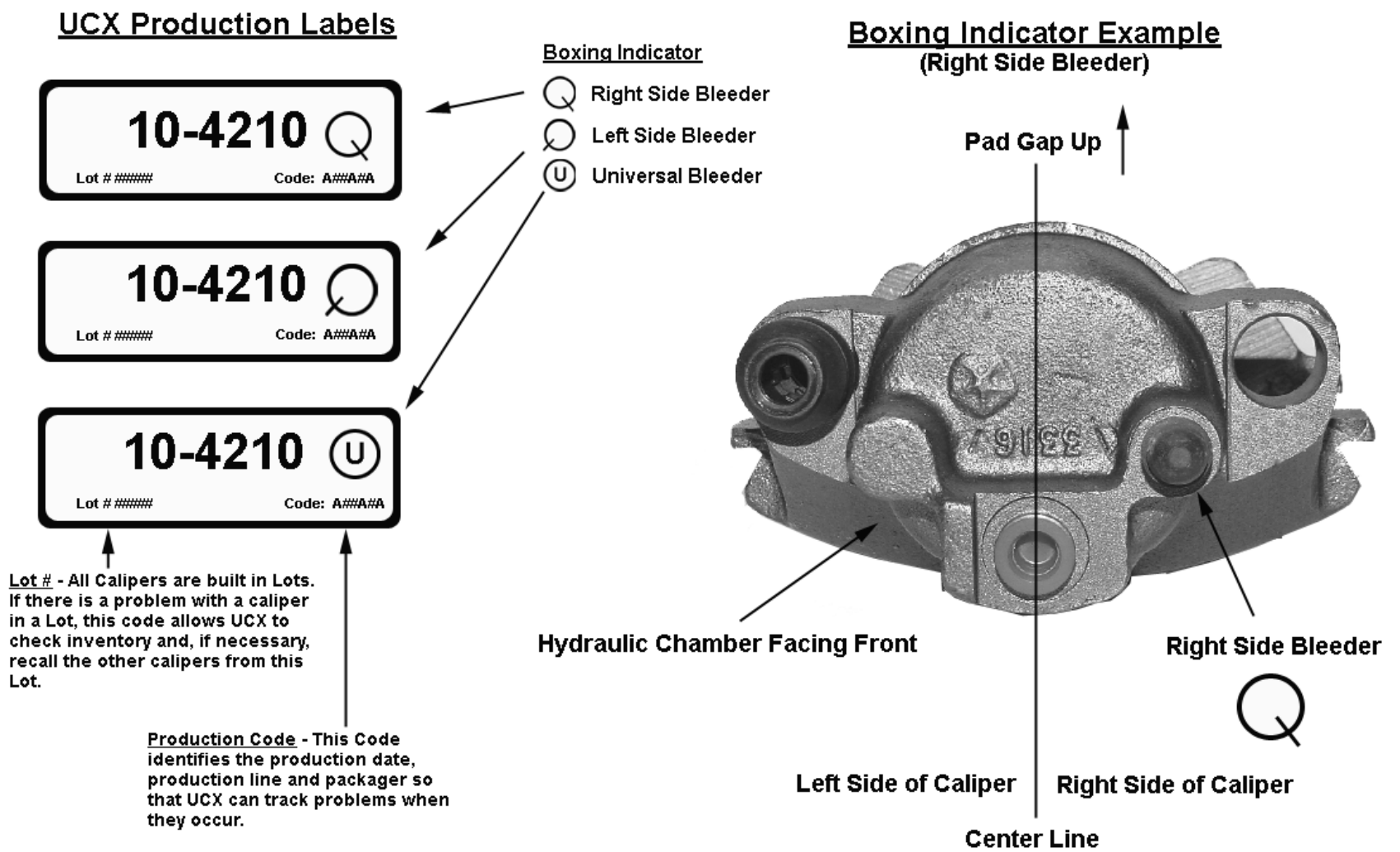

UCA

Precision Designed with the Technician in Mind™

DIAGNOSING A LOW, SPONGY OR DROPPING BRAKE PEDAL

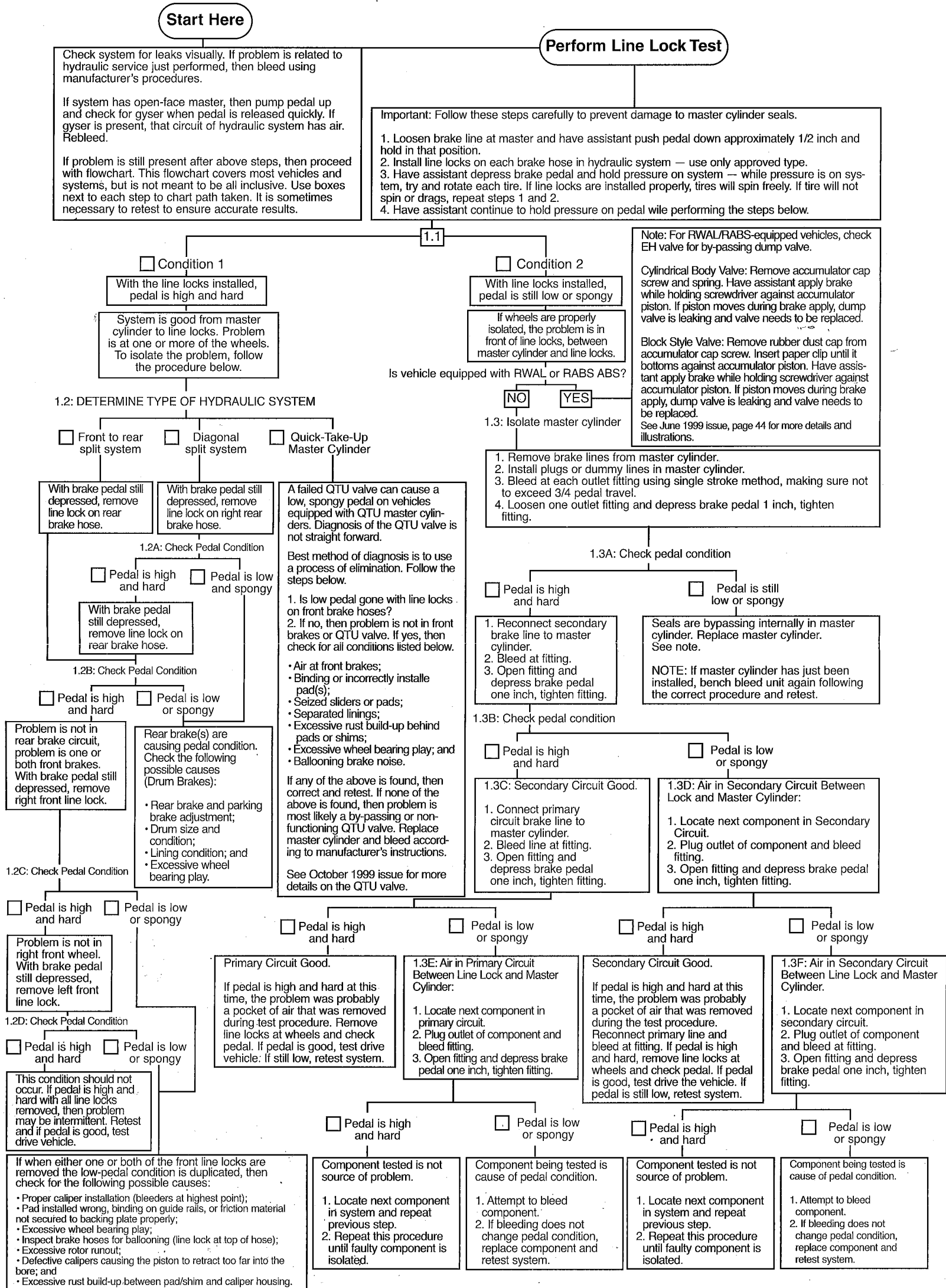

UCX.

*Precision Designed with
the Technician in Mind™*

Understanding Pad Wear Patterns

The Basics of Disc Brake Systems

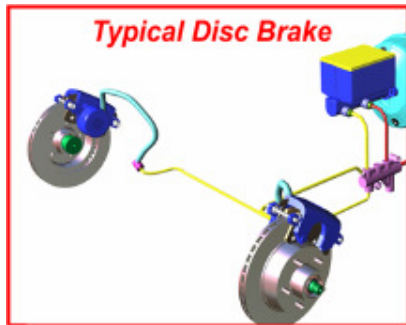

Disc brakes are found on the front of all modern vehicles. Because of their advantages over drum brakes they are also being used on the rear of many vehicles.

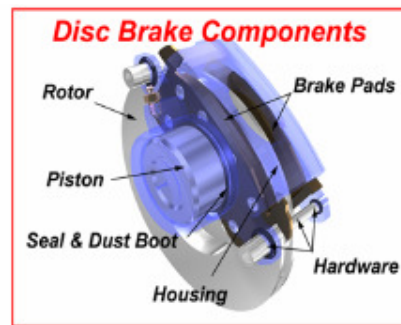

The figure above shows the main parts of the disc brakes. Each part in the disc brakes performs an important function. If any of the parts above are not working properly then problems will arise.

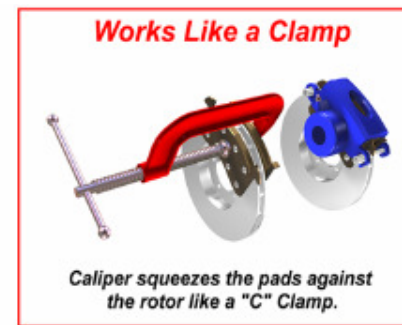

Caliper squeezes the pads against the rotor like a "C" Clamp.

Disc brakes work by squeezing the brake pads against the rotor. The way they do this is similar to a "C" clamp. As the pads are squeezed against the rotor it creates friction which stops the rotor. Because the brake pads are rubbing against the rotor when the brakes are applied they will wear. Brake pad replacement is the most common repair on disc brakes.

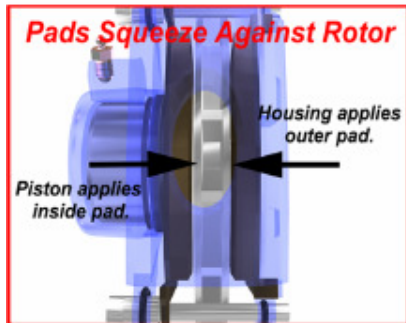

The piston is responsible for applying the inside pad. The pressure from the master cylinder pushes it out. The same pressure causes the caliper housing to move in towards the center of the vehicle (to the left in the above figure). The housing "floats" on the caliper hardware. This applies the outside pad. The result is that the pads squeeze against the rotor bringing it to a stop.



The square cut seal is a rubber "spring". It releases the brakes when the pedal is released.

A special seal inside the caliper performs some very important functions. First it prevents any brake fluid from leaking out. It also performs another critical job - it is what releases the brakes after you take your foot off the brake pedal. When the brakes are applied it is stretched. Because it is rubber, when the brakes are released it returns to its original shape. As it does this, it pulls the piston back in which release the brakes.



If the caliper hardware is not working properly the pads may wear prematurely.

The caliper hardware is what allows the caliper housing to move in and out. This is how the outside pad is applied and released. If the hardware is corroded or not lubricated properly then the caliper will not work correctly causing premature pad wear.

Condition 1

Outboard pad worn, all others normal

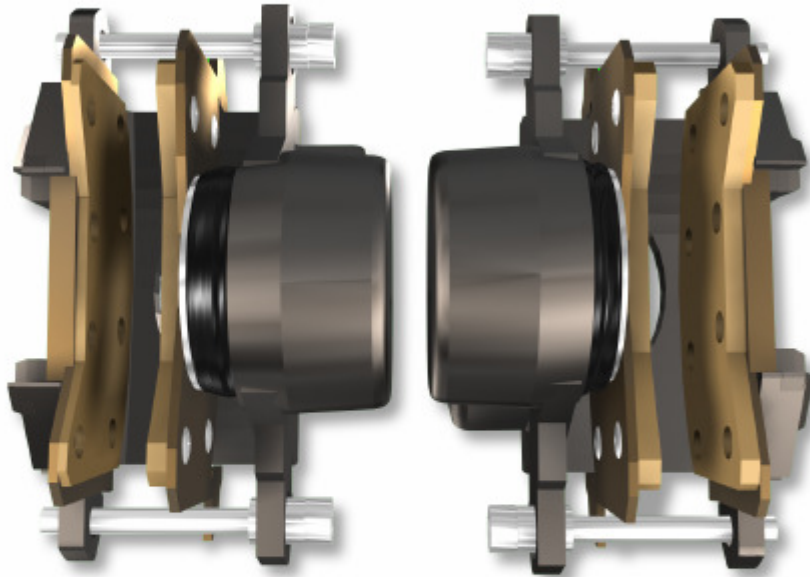

This is one of the most common pad wear conditions. Most vehicles use floating or sliding calipers. In these design calipers the housing is allowed to move in order to apply the outboard pad. If anything happens to prevent the smooth movement of the housing the outboard pad will wear faster than the other pads.

Top Figure: Rust is by far the most common cause of outboard pad wear. The rust doesn't allow the housing to move freely.

Middle Figure: Ripped dust boots allow moisture and salt to enter around the slider pins. This allows corrosion to occur which prevents smooth housing movement.

Bottom Figure: Lack of lubrication or the wrong lubrication will cause the housing to stop moving freely. This will cause the outboard pad to wear.

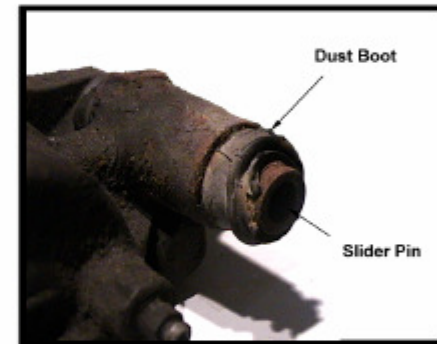

Condition 2

*Inboard pad worn,
all others normal*

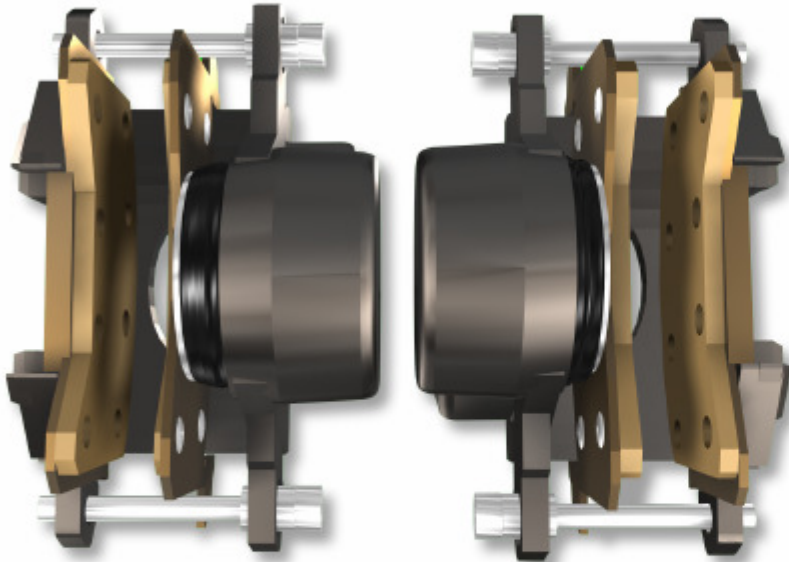

Most people think when the inboard pad wears before the outboard pad on the same caliper the caliper piston is sticking. This is incorrect. If the piston does not release or releases too slowly, both pads will be affected. The outboard pad cannot release until the inboard does. Usually inboard pad wear is caused by seized sliders. The caliper housing can no longer move due to corrosion.

Top Figure: If the plating on the slider pins corrodes it can seize the caliper housing preventing it from moving.

Middle Figure: Many calipers use rubber sleeves and bushings to allow the caliper to slide. Rust around these parts "squeezes" the slider pin.

Bottom Figure: If the wrong type of lubricant is used on the metal to rubber parts the rubber will swell preventing the caliper from moving.

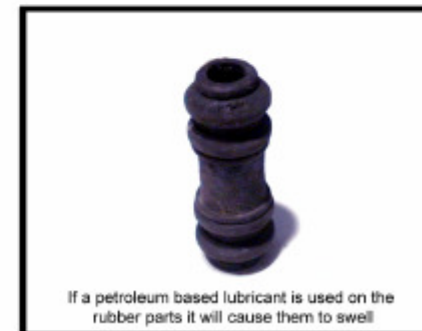
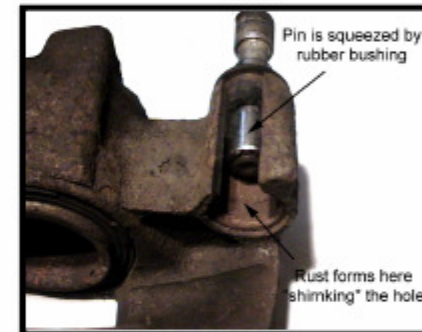
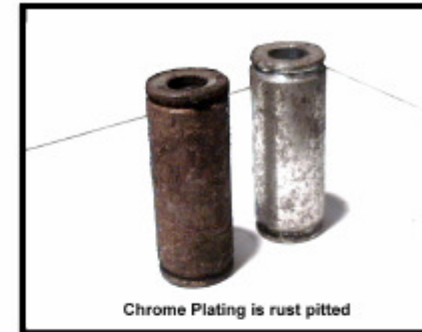

Condition 3

Both pads on one caliper worn, other caliper normal

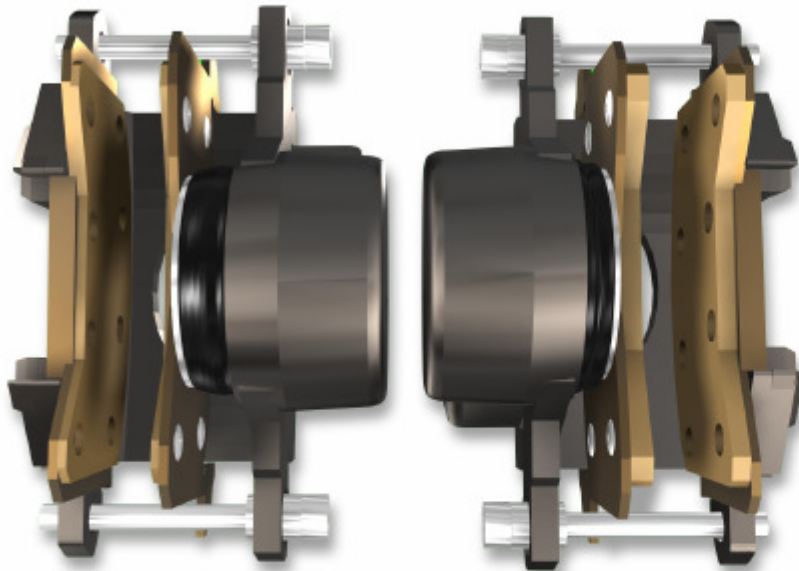

When the pads on one caliper wear faster than the other caliper it is either a problem with the caliper or an imbalance condition caused by a problem somewhere else in the system.

Top Figure: Before condemning the caliper check the condition of the piston by pulling back the dust boot. If the piston is severely corroded it can cause both pads to wear on that caliper.

Middle Figure: Brake hoses can fail in a manner that could cause this wear pattern. The hose on the left could have a "check valve" condition preventing the caliper from releasing. The right hose could be restricted preventing the right caliper from doing its share of the work.

Bottom Figure: If the vehicle is a FWD there could be a diagonal imbalance where the right front and left rear are doing their share of the work.

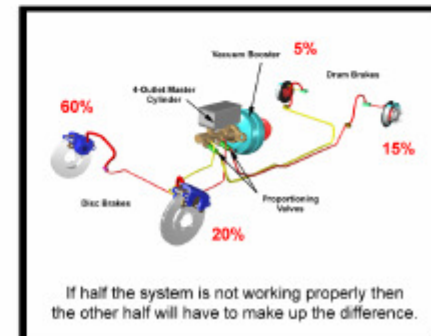
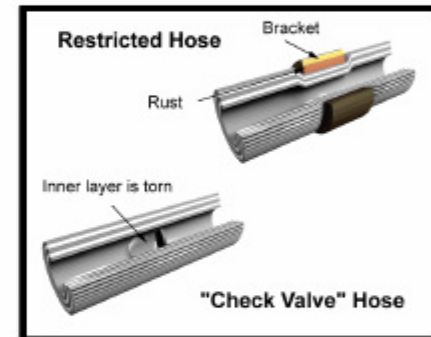

Condition 4

*All pads worn evenly
but prematurely*

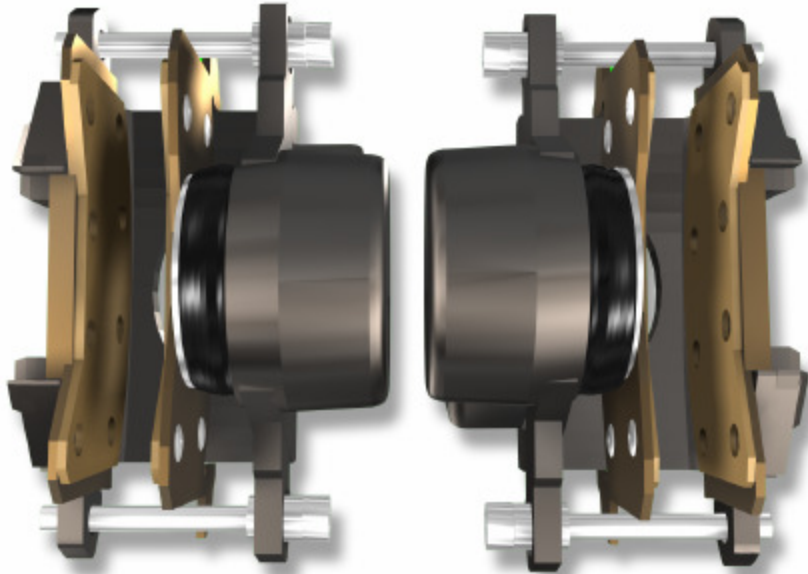

There are a number of different causes of rapid front pad wear. A thorough inspection of the brake system is necessary to determine the exact cause.

Top Figure: If the rear brakes are not working properly then the front brakes will be overworked resulting in premature wear.

Middle Figure: A restricted vent port in the master cylinder will cause the front brakes to drag when they get hot resulting in premature wear.

Bottom Figure: The customer's driving habits may be responsible for the premature wear. "Two footed" driving normally results in premature wear of the front brakes.

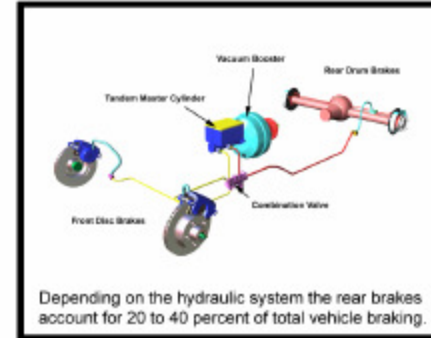

Depending on the hydraulic system the rear brakes account for 20 to 40 percent of total vehicle braking.



As the brakes get hot the brake fluid in the calipers expands. If it cannot return to the reservoir through the vent port it will cause brake drag.



Drivers who rest their left foot on the brake pedal can cause the same problems as a restricted vent port.



Levered REAR Caliper Piston Adjustment

For almost all brake calipers that have an internal parking brake mechanism (parking brake lever arm), it may be necessary to manually adjust the piston prior to installation to assure proper hand brake operation.

These directions are general for all levered style brake calipers and are intended to alert the installer that manual piston adjustment may be necessary, but be sure to consult the OE manufacturer's directions if needed.

1. Using the appropriate piston adjustment tool (that matches the piston face style. See below), turn the piston inward (Clockwise) until it is at bottom of bore and the piston locating notch will align with any dimple on the brake pad plate.
2. With a marker, make a locating mark on the piston face notch and the caliper so you can use this as a reference point.
3. Screw outward (Counter Clockwise) the piston until one full rotation of the reference point is achieved.

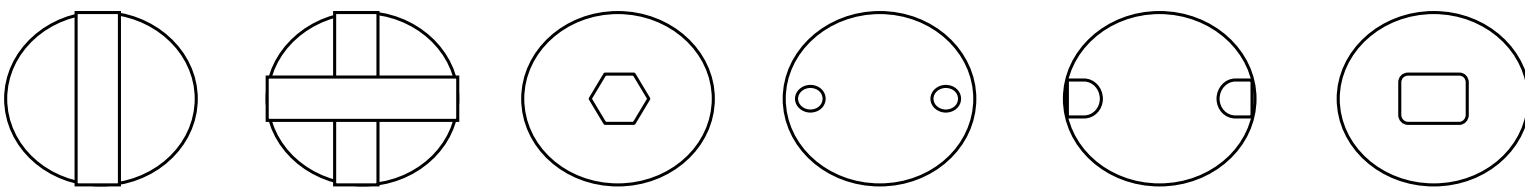



Aluminum Caliper Corrosion Alert

Starting in about 1997 many auto makers began to use aluminum instead of cast iron for their disc brake calipers. Aluminum is 65% lighter than iron and aluminum forgings and alloys can have the same structural strength as iron components. The auto makers liked the weight reduction because it helps boost gas mileage. However, they did not count on the problem posed by galvanic corrosion.

Galvanic corrosion occurs when there is contact between dissimilar metals in the presence of an electrolyte. One of the metals becomes the anode that gives up electrons and corrodes faster than it would alone. The other metal becomes the cathode that accepts the electrons and corrodes more slowly than it would alone.

For galvanic corrosion to occur, three conditions must be present: 1) Electrochemically dissimilar metals must be present; 2) the metals must be in electrical contact and 3) the metals must be exposed to an electrolyte. This type of corrosion often occurs between radiators, engine blocks and aluminum housings on water pumps.

In the case of aluminum disc brake calipers, galvanic corrosion occurs at the inlet and bleeder. At the inlet, you have the aluminum casting, the steel banjo bolt and hose block and the copper washers used to seal the banjo bolt and hose block. The electrolyte is a mixture of sodium chloride (salt) and water. At the bleeder you have the same situation between the aluminum casting and the steel bleeder screw.

The galvanic corrosion on aluminum disc brake calipers occurs most frequently on the sealing surface around the inlet hole on the aluminum casting. The aluminum is the anode and loses electrons to the copper washer and steel hose block and banjo bolt. The result is excessive pitting around the inlet potentially causing a break in the seal (and possible leak) between the copper washer and the aluminum casting.

In many cases, aluminum castings cannot be rebuilt because of the excessive pitting around the inlet. Technicians need to do a close inspection of the calipers coming off the vehicle to determine if the sealing surface around the inlet is pitted resulting in a scrap (unrebuildable) core. If the core is scrap, no core credit will be forthcoming from the supplier of the replacement caliper. Additionally, Technicians should inspect the castings on the replacement unit. If the rebuilder is not conscientious about inspecting the aluminum casting before shipping, he/she will end up with a hose block that will not seal upon installation on the vehicle.

All vehicles that use aluminum calipers will have the problem of galvanic corrosion. Some common vehicles to be aware of are:

- The front calipers on the Chevy Malibu 1997-2005, Olds Alero 1999-2004, Olds Cutlass 1997-1999 and Pontiac Grand Am 1999-2005.
- The rear calipers on the Chevy Blazer 1998-2005, Chevy S-10 Pickup 1998-2004, GMC Sonoma 1998-2004, GMC Jimmy 1997-2001, Isuzu Hombre 1998-2000 and Olds Bravada 1997-2001.

UCX

*Precision Designed with
the Technician in Mind™*

Some Facts About Brake Fluid Flushing **It's the Most Neglected Fluid in the Vehicle**

—by Larry Hammer

The purpose of the brake fluid is to transfer force under pressure from the master cylinder to the calipers/wheel cylinders. Non-contaminated fluid is imperative in order to maintain good brakeability, and to retain a high boiling point to prevent gassing and brake pedal fade.

Brake fluid is the most important and yet the most neglected fluid in the vehicle. No attention is given to it until a brake problem or a system overhaul occurs. The fluid extracted may be only a fraction of the system's total capacity. Some vehicle manufacturers specify a mileage or time interval for a brake fluid flush. Others state "as required," or "when system contamination occurs."

The industry accepted standard for a system flush is two years or 24K miles. Some new technology that allows field testing of the fluid may just change the way we think, as well as the customer's decision to have the brake system flushed.

SYSTEM CONTAMINATION

Most consider moisture to be the single contaminating element in the braking system. Considering the hygroscopic nature of the brake fluid, moisture is definitely a problem. Moisture may enter the system through the hoses, seals, master cylinder cover, etc. It is imperative that you keep the brake fluid container tightly sealed when not in use. The system can absorb 2% of its volume in moisture in 12 months. Just leaving the container open on the bench may result in the fluid failing a moisture test. A Dot 3 brake fluid with a 3% moisture accumulation encounters a 25% drop in the boiling point. A Dot 4 fluid has a higher dry boiling point than the Dot 3 fluid, but the wet boiling point may fall more rapidly than the Dot 3 when subjected to moisture.

Dot 3 fluids are comprised of mixtures of glycols and glycol ethers. Dot 4 fluid contains the same mixtures as Dot 3 fluid, but includes borate esters. Both fluids are compatible with the systems and the internal components, but may behave differently when subjected to moisture. A Dot 4 fluid will require more frequent flushes than a Dot 3 fluid. Fluid with a 3% moisture content or higher may not exhibit a braking concern under normal braking. The brake system may perform perfectly when cold, and then encounter pedal fade under aggressive braking. This is due to the fluid in the calipers or wheel cylinders being exposed to high heat, causing the fluid to boil and vaporize. The vapor is a gas and is compressible. The result is a spongy pedal, or in some cases a total loss of pedal. When the system cools, the vapor reverts to a liquid, and normal braking is restored. Moisture in the system may not be evident until periods

of aggressive, heavy or extended braking, and that's not the time to encounter a spongy or dropping pedal.

Moisture creates another major problem in the system, to which little attention has been given, and that is internal corrosion. Until recently, there has been no means of field testing for corrosion. If corrosion inhibitors are present in the fluid, a 5% moisture accumulation will not cause corrosion in the system. However, that level of moisture will deteriorate the corrosion inhibitors in the fluid. Once they are exhausted, a minute amount of moisture will promote corrosion. Studies show that 91% of the corrosion

inhibitors may be lost in 36 months. The brake fluid is exposed to a minimum of six different types of metals, rubber components, plastic, and a wide range of temperatures. The fluid must be compatible with these materials and maintain stable performance characteristics over a broad range of temperatures.

FIELD TESTING FOR CONTAMINATION

Field testing of brake fluid has been limited to testing for the presence of moisture. By the time the fluid fails a moisture test, chances are major damage has already been incurred. The moisture depletes the corrosion inhibitors in the fluid, resulting in corrosion damage to the components. Caliper bores, wheel cylinders, the master cylinder and ABS components become pitted, resulting in sticking and binding components and seal leakage. A new technology named FASCAR (Fluid Analysis by Stimulation of Copper Alpha Reactions) has made field testing for fluid contamination simple. The test involves dipping a test strip (Strip Dip) into the brake fluid in the master cylinder reservoir for one second and then waiting for 30-120 seconds for the test results. The reaction zone on the test strip will change color in relation to the condition of the fluid. Compare the color on the test strip to the color graph provided. The presence of copper indicates that system corrosion is occurring. The copper alloy in the brake lines will be the first metal susceptible to the corrosive elements. Fluid that measures 200 PPM (parts per million) of copper or higher should be removed with a system flush.

Mileage has nothing to do with the age of the fluid. Fluid in a 10K mile vehicle may have aged more than a like vehicle with 30K miles. The condition of the fluid is determined by factors such as the customer's braking habits, pulling or hauling a heavy load, high brake temperatures, mountainous driving, etc., all of which accelerate the breakdown of the corrosive inhibitors. Brake fluid wears out and should be changed, just like antifreeze must be replaced to restore the cooling system's corrosive inhibitors. ■



FRANTICALLY PUMPING HIS BRAKES, WALTER SAYS HELLO TO THE FULLY-LOADED MANURE SPREADER, RECALLING WITH PARTICULAR SADNESS HOW HE IGNORED THE WARNING OF CONTAMINATED BRAKE FLUID.



Brake Inspection & Maintenance Checklist

Modern brakes stop you amazingly well...that is, when they're working. Unfortunately, today's brake systems are very complicated. There are numerous and frequent problems that can affect not only the pleasure of your customers' drive, but also their safety and their very survival.

So, you need to follow these steps at least once a year:

ROAD TEST

- Brake lights work?
- Pull to one side?
- Excessive pedal effort?
- Pedal low?
- Pedal spongy?
- Pedal sinks to floor?
- Pedal pulsation?
- Pedal grabs?
- Dragging?
- Parking brake holds/releases?
- Brake warning light on?

NOISE:

- Squealing/squeaking?
- Grinding?
- Clunking?

INSPECTION ITEMS

Hydraulic System:

- Brake fluid level
- Brake fluid contamination
- Brake hose condition
- Leaks at calipers/wheel cylinders
- Frozen bleeder screws

ABS:

- Warning light
- Pedal pulsation

Vacuum Booster:

- Vacuum hose condition
- Vacuum hose connections
- Check valve condition

Hydraulic Booster:

- Power steering fluid level
- Power steering pump noise
- Power steering pump belt condition/tightness
- Power steering hose condition
- Fluid tightness at booster, accumulator, connections

Disc Brakes:

- Lining thickness
- Lining condition
- Pad fit in caliper
- Rotor surface
- Rotor run-out and parallelism
- Rotor thickness
- Caliper bushing, guide pin, pad retainer condition
- Caliper mounting tightness
- Rear disc parking brake operation/adjustment
- Wheel bearing condition, lubrication, and adjustment
- Wheel bearing grease seal condition

Drum Brakes:

- Lining thickness
- Lining condition
- Drum surface
- Drum roundness
- Drum diameter
- Self-adjuster operation
- Condition of self-adjuster cable, hold-down and return springs

- Condition of backing plate shoe contact points
- Tightness of wheel cylinder to backing plate
- Lining-to-drum clearance adjustment
- Wheel bearing condition, lubrication, and adjustment
- Wheel bearing grease seal condition

Parking Brake:

- Cable condition
- Cable adjustment

Tires/Wheels:

- Tire inflation
- Tire condition
- Tire size/type match
- Wheel run-out
- Lug nut torque

MAINTENANCE ITEMS

- Flush/refill hydraulic system
- Free up bleeder screws, apply anti-seize to threads
- Lubricate star wheel adjusters
- Lubricate/adjust parking brake cables
- Repack/adjust wheel bearings
- Inflate tires to specs
- Rotate tires