



TYGER RIDER®

TG-SS2J35258

BEFORE INSTALLATION

READ INSTRUCTIONS CAREFULLY BEFORE STARTING INSTALLATION. REMOVE CONTENTS FROM BOX AND VERIFY ALL PARTS ARE PRESENT. FAILURE TO IDENTIFY DAMAGE BEFORE INSTALLATION COULD LEAD TO A REJECTION OF ANY CLAIM. IF MISSING PARTS OR ANY DAMAGE FOUND, PLEASE TAKE A PICTURE FOR THE CLAIM PURPOSE.

TORQUE VALUES

Fastener Size	Class 8.8 Torque (ft-lbs)	Class 10.9 Torque (ft-lbs)
6mm	6-7	6-7
8mm	15-16	22-23
10mm	31-32	44-45
12mm	54-55	78-79
14mm	87-88	125-126

- x1 Driver/Left Tyger Rider
- x1 Passenger/Right Tyger Rider
- x1 Driver/Left Front Mounting Bracket
- x1 Passenger/Right Front Mounting Bracket
- x1 Driver/Left Center Mounting Bracket
- x1 Passenger/Right Center Mounting Bracket
- x1 Driver/Left Rear Mounting Bracket
- x1 Passenger/Right Rear Mounting Bracket
- x1 Driver/Left Front Support Bracket
- x1 Passenger/Right Front Support Bracket
- x2 Driver/Left Center/Rear Support Brackets

Parts List

- x2 Passenger/Right Center/Rear Support Brackets
- x6 10-1.5mm x 30mm Hex Bolts
- x12 10mm x 24mm OD x 2.2 Flat Washers
- x6 10mm Nylon Lock Nuts
- x6 8—1.25mm x 35mm Hex Bolts
- x12 8-1.25mm x 25mm Combo Bolts
- x6 8mm Lock Washers
- x6 8mm x 23mm OD x 3mm Flat Washers
- x12 6-1.0mm x 25mm Hex Bolts
- x24 6mm x 22mm OD x 2mm Flat Washers
- x12 6mm Nylon Lock Nuts

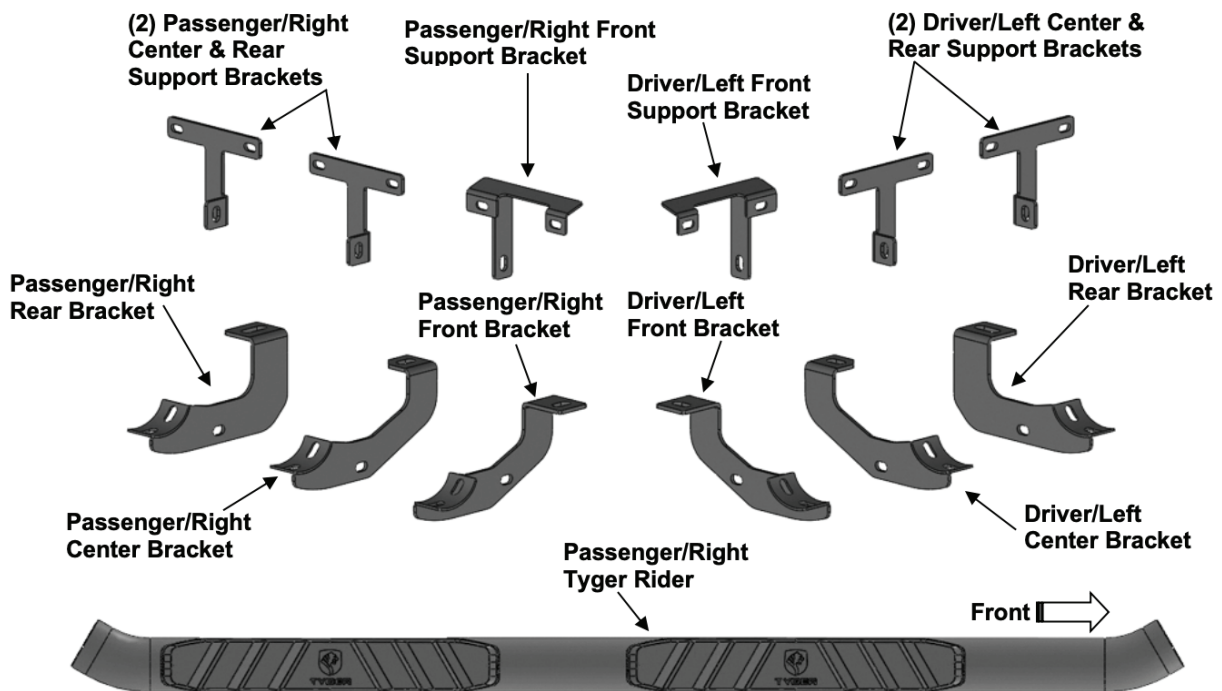



STEP 1

REMOVE CONTENTS FROM BOX. VERIFY ALL PARTS ARE PRESENT. READ INSTRUCTIONS CAREFULLY BEFORE STARTING INSTALLATION. SIDE STEPS OR RUNNING BOARDS MUST BE REMOVED BEFORE INSTALLATION.

STEP 2

Start installation on the Passenger/Right front of the of the vehicle. Find the front threaded insert located in between the first pair of holes along the pinch weld (Fig 1).

Passenger /Right Side Installation Pictured

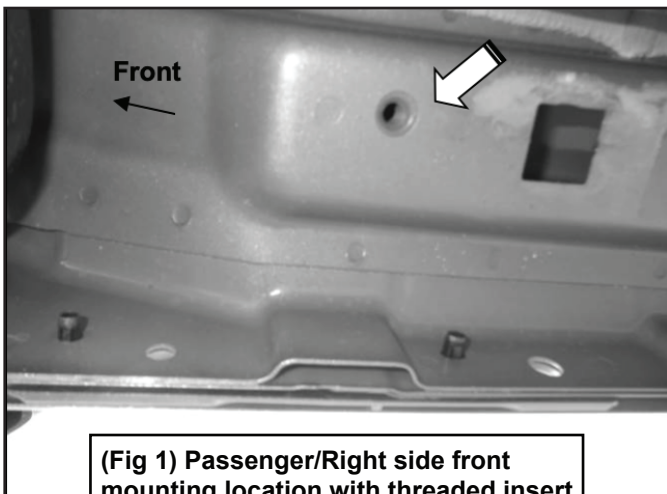

(Fig 1) Passenger/Right side front mounting location with threaded insert

STEP 3

Select the Passenger/Right Front Mounting Bracket.

IMPORTANT: Use the illustration above to properly identify the Mounting Bracket. Attach the Mounting Bracket to the threaded insert using (1) 8mm Hex Bolt, (1) 8mm Lock Washer and (1) 8mm Flat Washer (Figs 2 & 3). DO NOT tighten hardware at this time.

Passenger /Right Side Installation Pictured

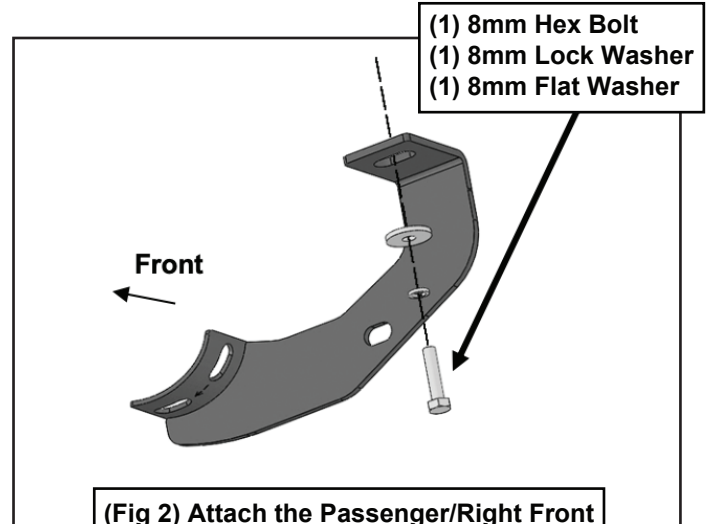

(Fig 2) Attach the Passenger/Right Front Mounting Bracket to the front location

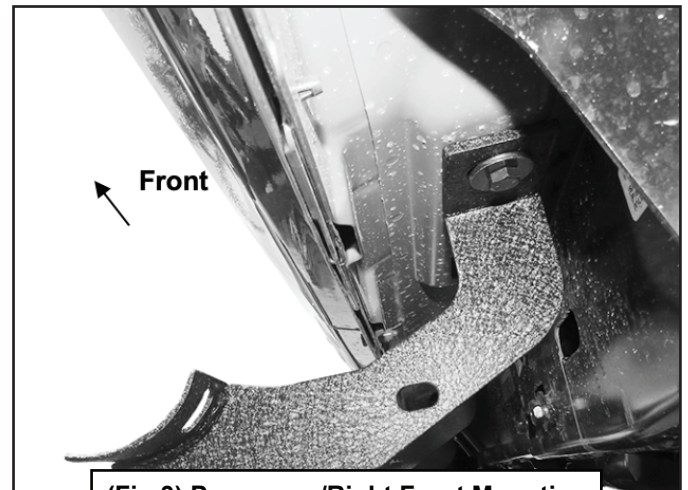

(Fig 3) Passenger/Right Front Mounting Bracket attached to the front location

STEP 4

Select the Passenger/Right Front Support Bracket.

IMPORTANT: Use the illustration above to help identify the correct Support Bracket. Attach the Support Bracket to the pinch weld using (2) 6mm Hex Bolts, (4) 6mm Flat Washers and (2) 6mm Nylon Lock Nuts (Fig 4).

NOTE: Insert bolts from the outside of the pinch weld. Attach the Support Bracket to the Mounting Bracket with (1) 10mm Hex Bolt, (2) 10mm Flat Washers and (1) 10mm Nylon Lock Nut (Figs 4 & 5). DO NOT tighten hardware at this time.



Passenger /Right Side Installation Pictured

(Fig 4) Attach the Passenger/Right Front Support Bracket to the pinch weld

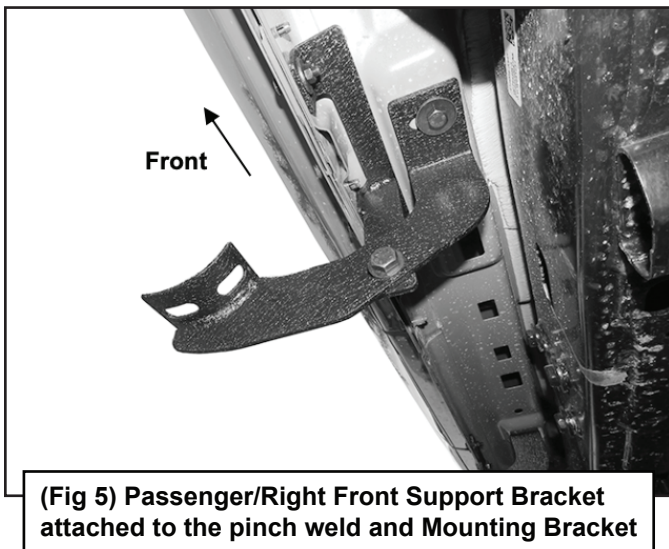
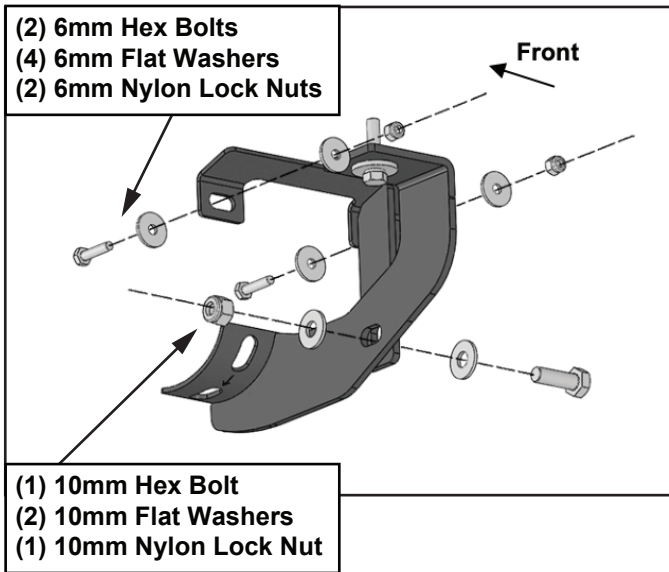

STEP 5

Move to the center mounting location and locate the threaded insert and pair of holes in the pinch weld (Fig 6). Repeat **STEPS 3 & 4** to attach (1) Passenger/Right Center Mounting Bracket and (1) Center Support Bracket (Figs 6-8).

NOTE: The Center and Rear Mounting Brackets look similar but each one is unique. The Center Mounting Bracket Bracket has a notch in the mounting tab (Fig 7). **DO NOT** tighten hardware at this time.

Passenger /Right Side Installation Pictured

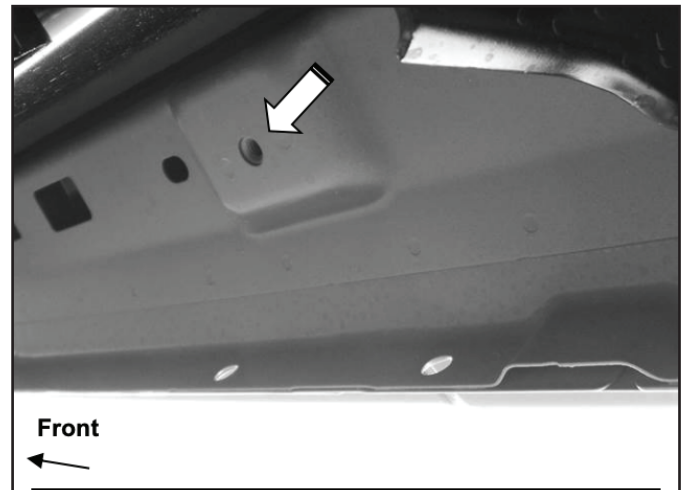

(Fig 6) Passenger/Right center mounting location

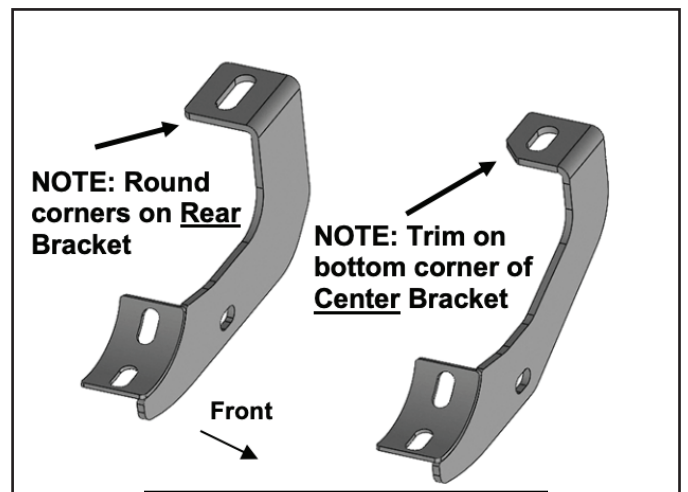

(Fig 7) Passenger/Right Center & Rear Mounting Brackets

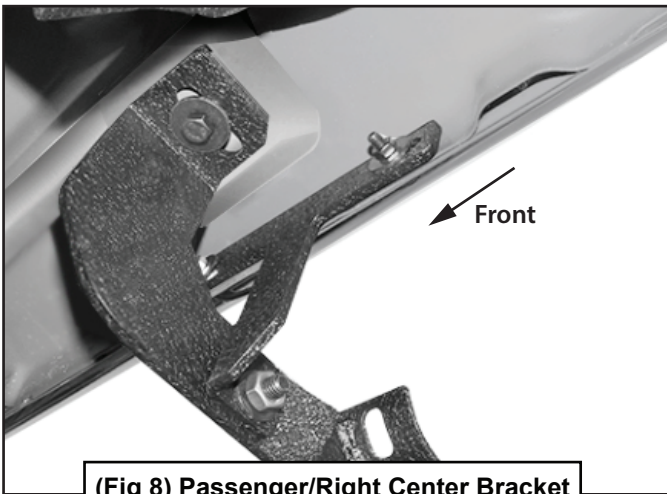

(Fig 8) Passenger/Right Center Bracket attached to Center Support Bracket

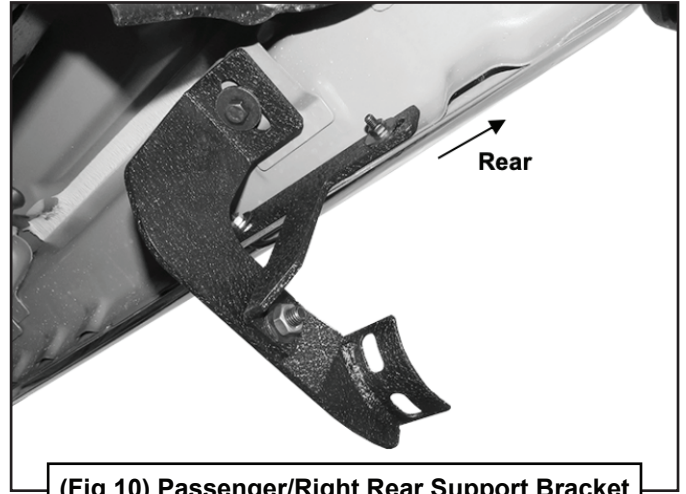

(Fig 10) Passenger/Right Rear Support Bracket attached to pinch weld and Mounting Bracket

STEP 6

Move to the rear mounting location on the rocker panel and locate the threaded insert and pair of holes in the pinch weld (Fig 9). Repeat **STEPS 3 & 4** to attach (1) Passenger/Right Rear Mounting Bracket and (1) Rear Support Bracket (Figs 9 & 10). **DO NOT** tighten hardware at this time.

Passenger /Right Side Installation Pictured

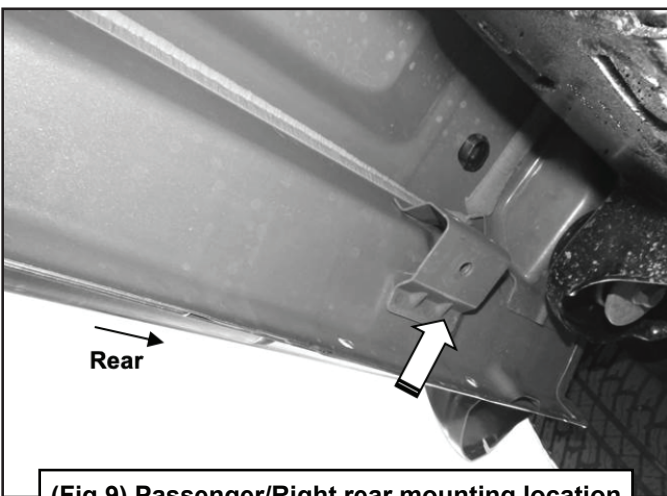

(Fig 9) Passenger/Right rear mounting location

STEP 7

Select the Passenger/Right Sidebar. Use the illustration above to select the correct Sidebar. Carefully position the Sidebar onto the (3) Mounting Brackets.

IMPORTANT: **DO NOT** slide, (front to back or rotate), the Sidebar on the Brackets or damage to the finish on the Sidebar may result. Attach the Sidebar to the Mounting Brackets with (6) 8mm x 25mm Combo Bolts (Figs 11-14). **DO NOT** tighten hardware at this time.

Passenger /Right Side Installation Pictured

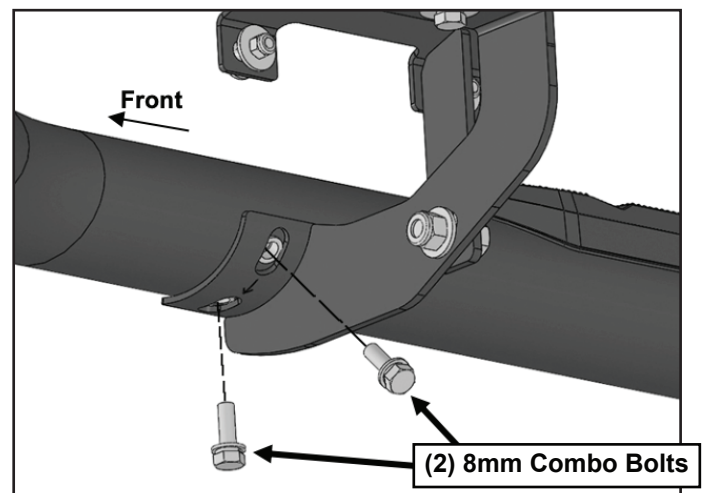

(Fig 11) Attach the Passenger/Right Tyger Rider to the Mounting Brackets

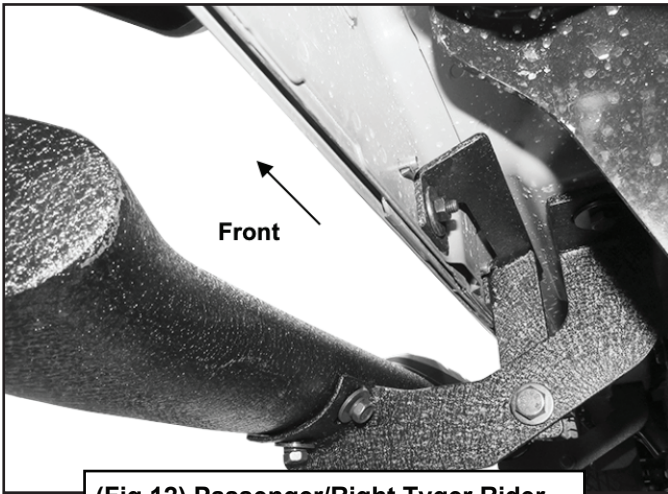

(Fig 12) Passenger/Right Tyger Rider attached to the Front Mounting Bracket

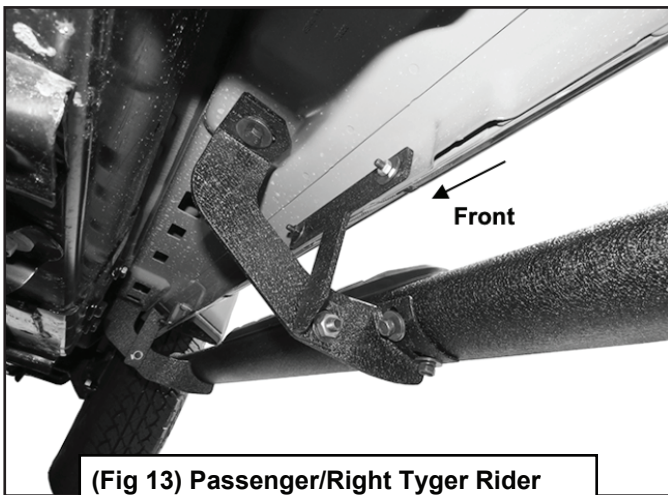

(Fig 13) Passenger/Right Tyger Rider attached to the Center Mounting Bracket

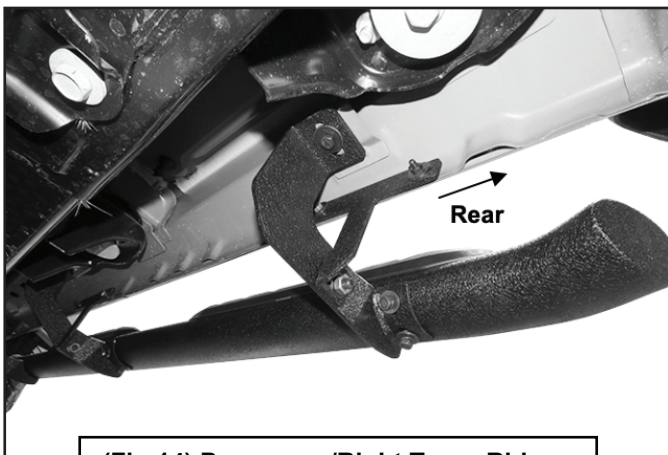

(Fig 14) Passenger/Right Tyger Rider attached to the Rear Mounting Bracket

STEP 8

Level and adjust the Sidebar and tighten all hardware.

STEP 9

Repeat **STEPS 1—8** for Driver/Left Sidebar installation.

STEP 10

Do periodic inspections to the installation to make sure that all hardware is secure and tight.