



TYGER®

TYGER RIDER®

TG-SS2J35238

BEFORE INSTALLATION

READ INSTRUCTIONS CAREFULLY BEFORE STARTING INSTALLATION. REMOVE CONTENTS FROM BOX AND VERIFY ALL PARTS ARE PRESENT. FAILURE TO IDENTIFY DAMAGE BEFORE INSTALLATION COULD LEAD TO A REJECTION OF ANY CLAIM. IF MISSING PARTS OR ANY DAMAGE FOUND, PLEASE TAKE A PICTURE FOR THE CLAIM PURPOSE.

TORQUE VALUES

Fastener Size	Class 8.8 Torque (ft-lbs)	Class 10.9 Torque (ft-lbs)
6mm	6-7	6-7
8mm	15-16	22-23
10mm	31-32	44-45
12mm	54-55	78-79
14mm	87-88	125-126

Parts List

- x1 Driver/Left Tyger Rider
- x1 Passenger/Right Tyger Rider
- x1 Driver/Left Front Mounting Bracket
- x1 Passenger/Right Front Mounting Bracket
- x1 Driver/Left Center Mounting Bracket
- x1 Passenger/Right Center Mounting Bracket
- x1 Driver/Left Rear Mounting Bracket
- x1 Passenger/Right Rear Mounting Bracket
- x3 Driver/Left Support Brackets
- x3 Passenger/Right Support Brackets
- x6 10-1.5mm x 35mm Hex Bolts
- x6 10-1.5mm x 30mm Hex Bolts
- x18 10mm x 30mm OD x 2.5mm Flat Washers
- x12 10mm Lock Washers Passenger/Right Front Mounting Bracket
- x6 10mm Hex Nuts
- x6 10mm Nut Plates
- x6 8-1.25mm x 35mm Hex Bolts
- x12 8-1.25mm x 25mm Combo Hex Bolts
- x6 8mm Lock Washers
- x6 8mm x 28mm OD x 3mm Flat Washers
- x12 6-1.0mm x 25mm Hex Bolts
- x24 6mm x 22mm x 2mm Flat Washers
- x12 6mm x 22mm x 2mm Flat Washers

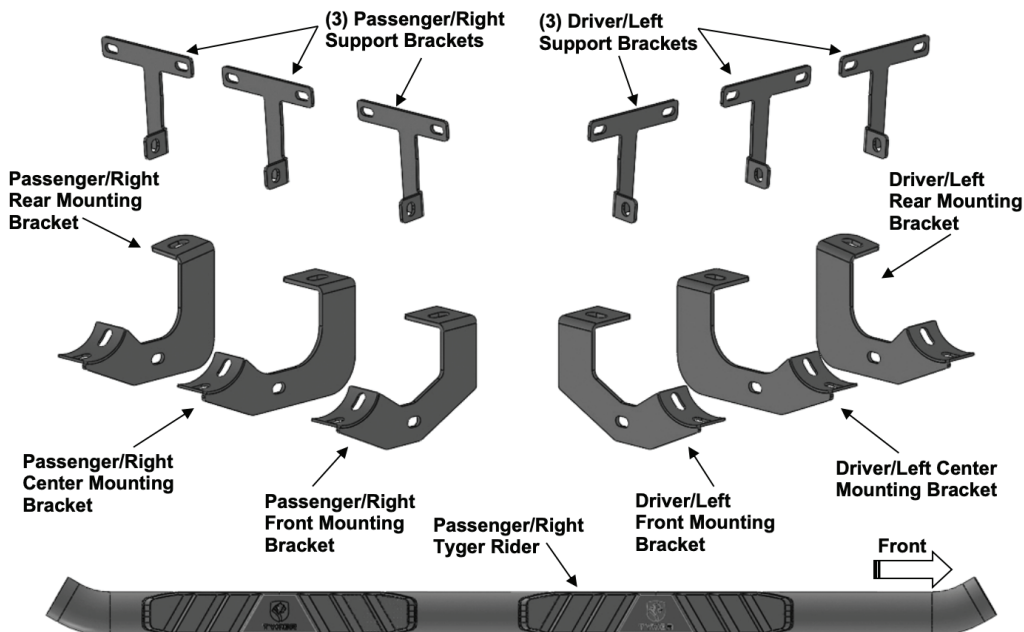

V201030



STEP 1

REMOVE CONTENTS FROM BOX. VERIFY ALL PARTS ARE PRESENT. READ INSTRUCTIONS CAREFULLY. FACTORY INSTALLED OR AFTERMARKET PRODUCT MUST BE REMOVED.

STEP 2

Start installation toward the front of the Passenger/Right side of the vehicle (Fig 1).

Passenger/Right Side Installation Pictured

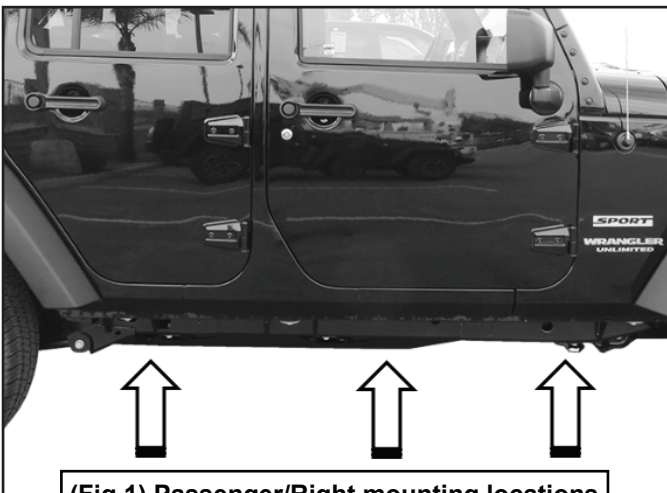

STEP 3

IMPORTANT: The Mounting Brackets look similar but are all unique. The Front Mounting Bracket has an angled back. The Center Mounting Bracket has a rounded back. The Rear Mounting Bracket has a rounded mounting tab and shorter bottom section (Fig 3).

Passenger/Right Side Installation Pictured

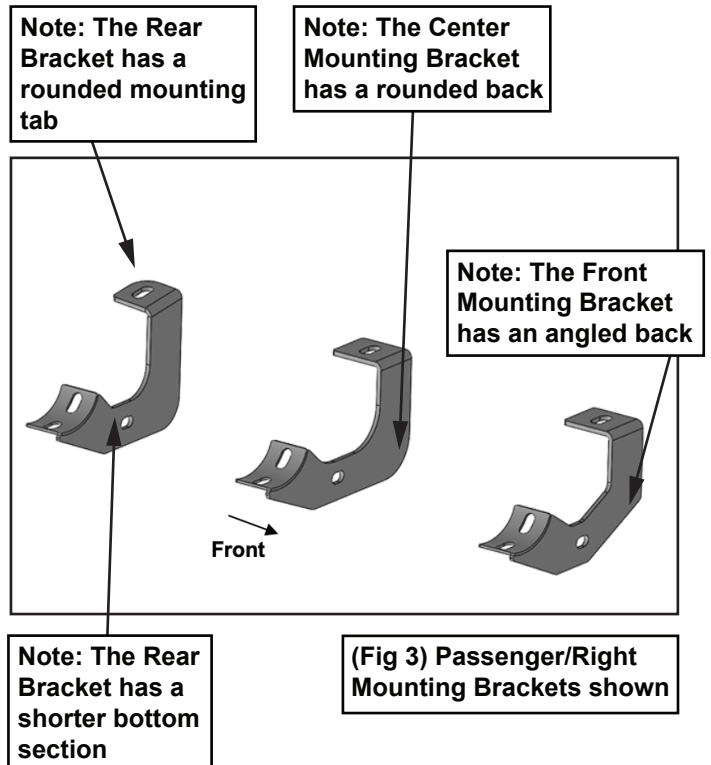

STEP 4

Determine if vehicle is equipped with threaded mounting inserts

Vehicles without threaded inserts:

- a. Insert (1) 10mm Nut Plate into the large square opening in the floor panel. Line up the threaded nut with the hole in between the pair of holes on the pinch weld (Figs 2A & 2B).

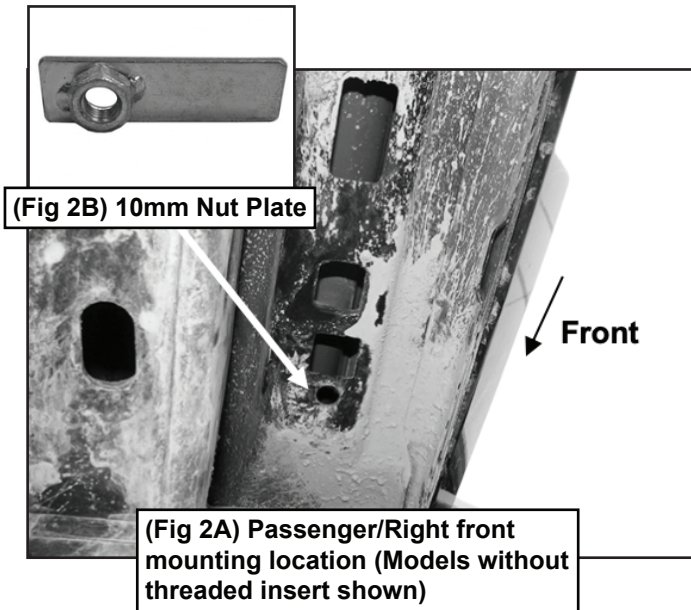

b. Select the Passenger/Right Front Mounting Bracket.

c. Attach the Bracket to the Nut Plate with (1) 10mm Hex Bolt, (1) 10mm Lock Washer and (1) 10mm Flat Washer (Fig 4). DO NOT tighten hardware.

10mm x 35mm Hex Bolt
10mm Lock Washer
10mm Flat Washer
10mm Nut Plate

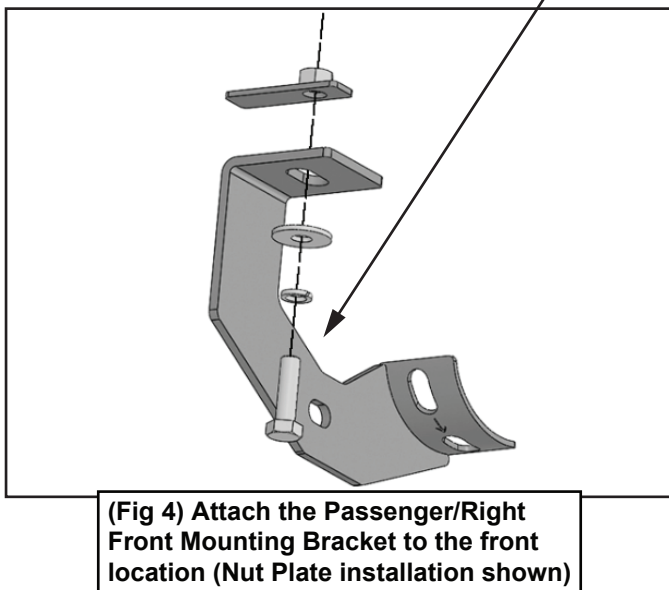

Vehicles with factory threaded hole in floor panel:

a. Locate the front, center and rear mounting locations (Fig 1)

b. Select the Passenger/Right Front Mounting Bracket.

c. Attach the Bracket to the front mounting location with (1) 8mm Hex Bolt, (1) 8mm Lock Washer and (1) 8mm Flat Washer (Fig 5). DO NOT tighten hardware.

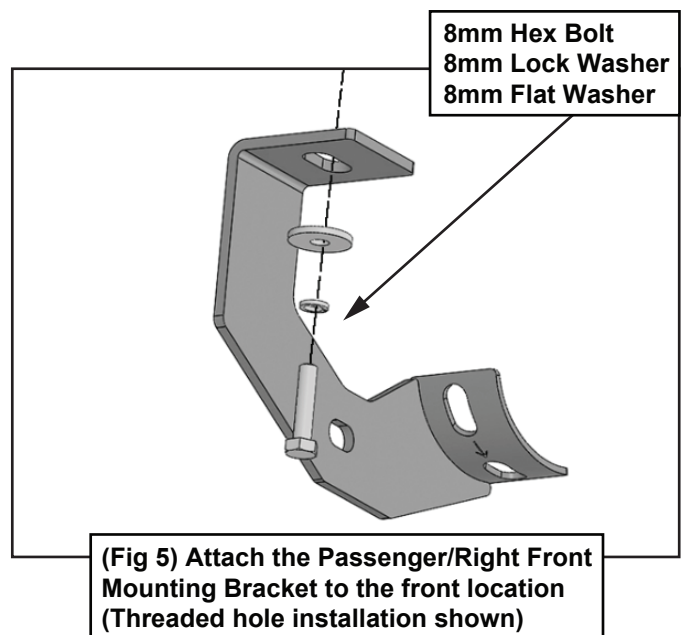

STEP 5

Select (1) Passenger/Right Support Bracket. Attach the Bracket to the pinch weld with (2) 6mm Hex Bolts, (4) 6mm Flat Washers and (2) 6mm Nylon Lock Nuts (Fig 6). DO NOT tighten hardware.

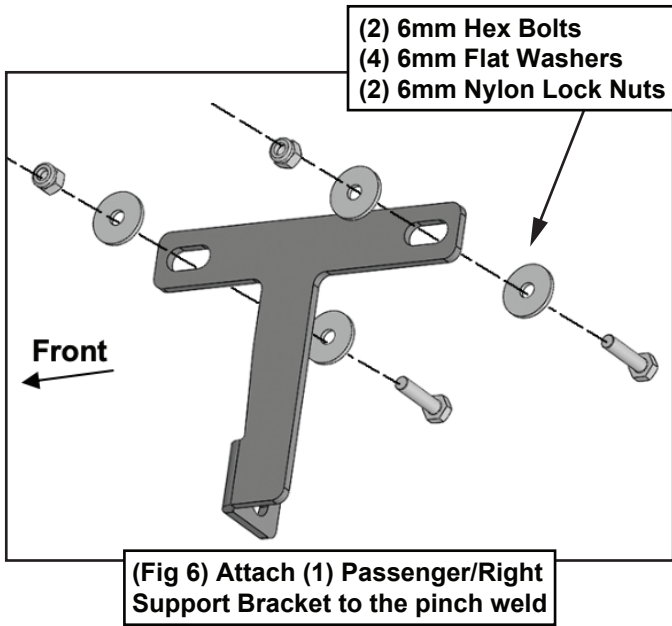

STEP 7

Repeat **STEPS 3—6** to attach the Bracket assemblies to the center and rear locations (Figs 8A, 8B & 9). **DO NOT** tighten hardware.

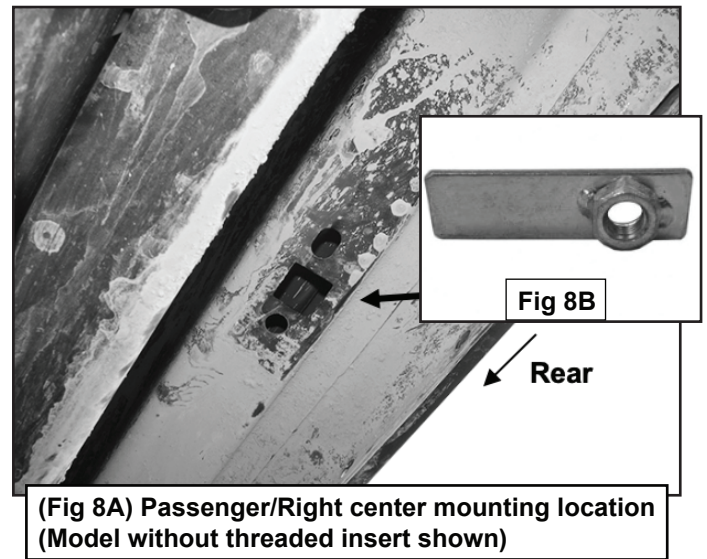

STEP 6

Attach the Support Bracket to the Mounting Bracket with (1) 10mm x 25mm Hex Bolt, (2) 10mm Flat Washers, (1) 10mm Lock Washer and (1) 10mm Hex Nut (Fig 7). **DO NOT** tighten hardware.

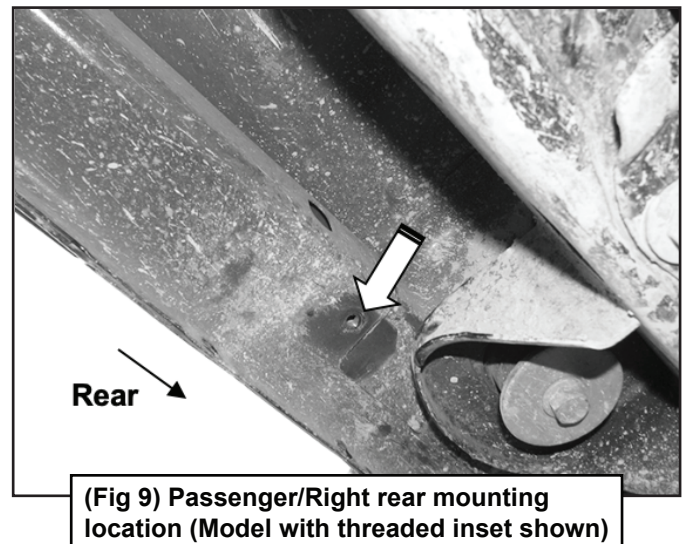
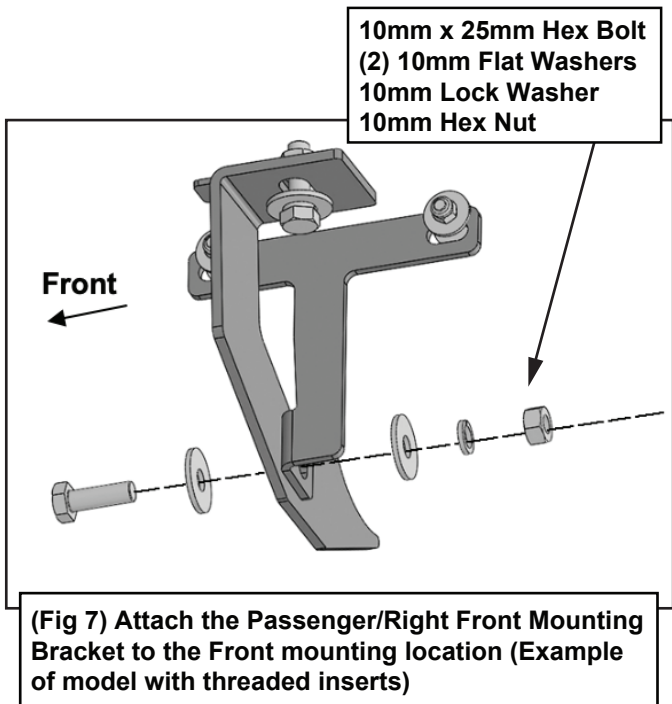



STEP 8

Select the Passenger/Right Tyger Rider. Carefully place Sidebar on the brackets.

IMPORTANT: DO NOT slide or rotate Sidebar on cradles, or damage to the finish may result. Attach Sidebar to the Mounting Brackets with (6) 8mm Combo Bolts (Fig 10). DO NOT tighten hardware.

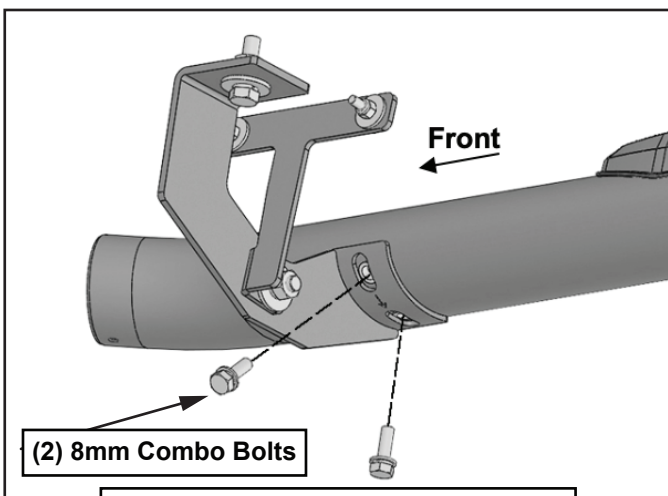

(Fig 10) Attach the Passenger/Right Tyger Rider to the Mounting Brackets

STEP 9

Level and adjust the Sidebar and tighten all hardware.

STEP 10

Move to the driver/left side of the vehicle. Repeat **STEPS 1—9** for driver/left Sidebar installation.

STEP 11

Do periodic inspections to the installation to make sure that all hardware is secure and tight.