



# TYGER®

## TYGER RIDER®

TG-SS2J35198

### BEFORE INSTALLATION

READ INSTRUCTIONS CAREFULLY BEFORE STARTING INSTALLATION. REMOVE CONTENTS FROM BOX AND VERIFY ALL PARTS ARE PRESENT. FAILURE TO IDENTIFY DAMAGE BEFORE INSTALLATION COULD LEAD TO A REJECTION OF ANY CLAIM. IF MISSING PARTS OR ANY DAMAGE FOUND, PLEASE TAKE A PICTURE FOR THE CLAIM PURPOSE.

### TORQUE VALUES

Fastener Size	Class 8.8 Torque (ft-lbs)	Class 10.9 Torque (ft-lbs)
6mm	6-7	6-7
8mm	15-16	22-23
10mm	31-32	44-45
12mm	54-55	78-79
14mm	87-88	125-126

## Parts List

- x1 Driver/Left Tyger Rider
- x1 Passenger/Right Tyger Rider
- x1 Driver/Left Front Mounting Bracket
- x1 Passenger/Right Front Mounting Bracket
- x1 Driver/Left Center Mounting Bracket
- x1 Passenger/Right Center Mounting Bracket
- x1 Driver/Left Rear Mounting Bracket
- x1 Passenger/Right Rear Mounting Bracket
- x1 Driver/Left Front Support Bracket
- x1 Passenger/Right Front Support Bracket
- x1 Driver/Left Center Support Bracket
- x1 Passenger/Right Center Support Bracket

- x1 Driver/Left Rear Support Bracket
- x1 Passenger/Right Rear Support Bracket
- x6 10-1.5mm x 30mm Hex Bolts
- x12 10mm x 24mm OD x 2.2mm Flat Washers
- x6 10mm Nylon Lock Nuts
- x6 8-1.25mm x 35mm Hex Bolts
- x12 8-1.25mm x 25mm Combo Bolts
- x6 8mm Lock Washers
- x6 8mm x 28mm OD x 3mm Flat Washers
- x12 6-1.0mm x 25mm Hex Bolts
- x24 6mm x 22mm OD x 2mm Flat Washers
- x12 6mm Nylon Lock Nuts

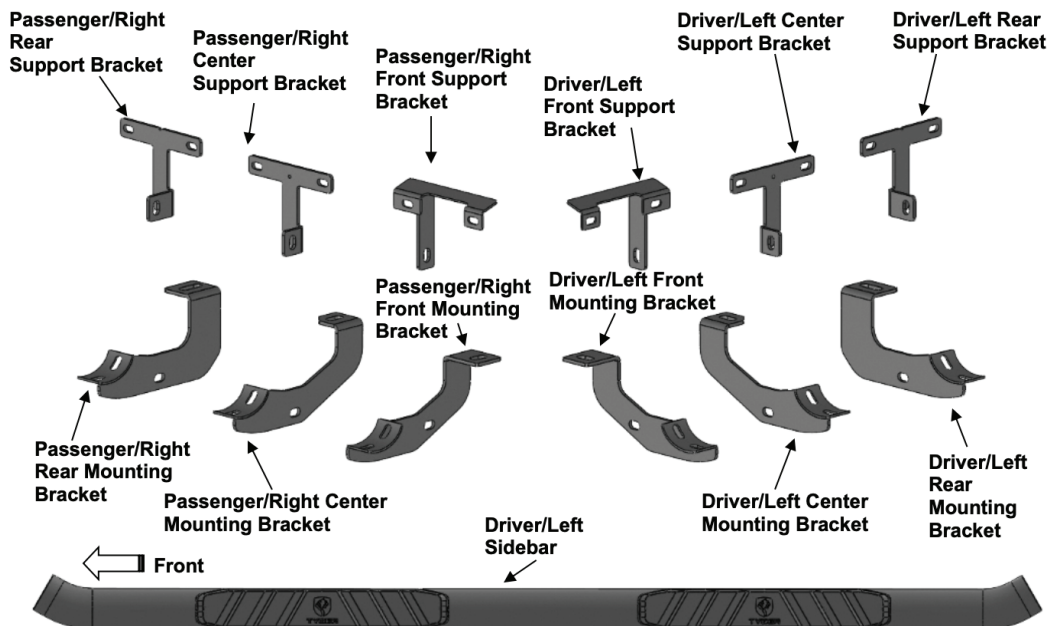

V201030



## STEP 1

REMOVE CONTENTS FROM BOX. VERIFY ALL PARTS ARE PRESENT. READ INSTRUCTIONS CAREFULLY BEFORE STARTING INSTALLATION. SIDE STEPS OR RUNNING BOARDS MUST BE REMOVED BEFORE INSTALLATION.

## STEP 2

Start installation on the Driver/Left front of the vehicle. Find the front threaded insert located in between the first pair of holes along the pinch weld (Fig 2). Installation will use the 1st, 2nd and 4th mounting locations (Fig 1).

Driver/Left Side Installation Pictured

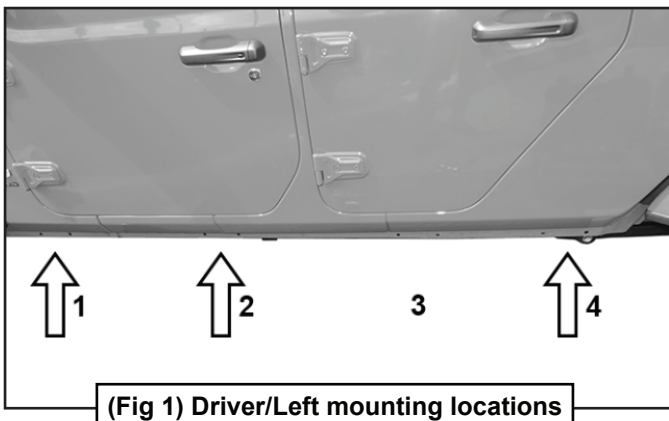

(Fig 1) Driver/Left mounting locations

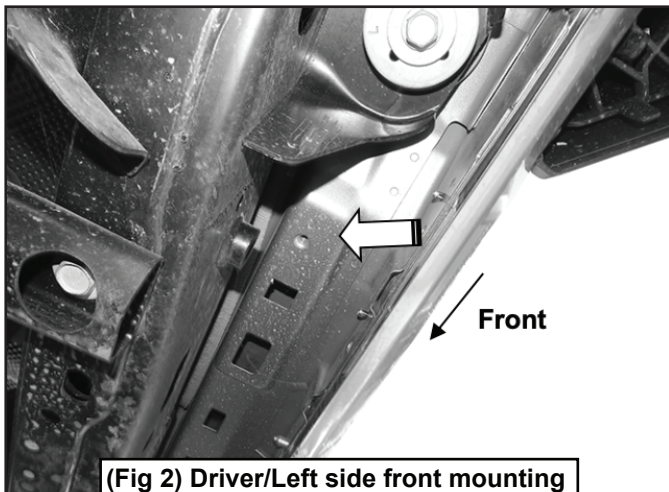

(Fig 2) Driver/Left side front mounting location with threaded insert

## STEP 3

Select the Driver/Left Front Mounting Bracket (Fig 3).

**IMPORTANT:** Use the illustration above and (Fig 3) to properly identify the Mounting Bracket. Attach the Mounting Bracket to the threaded insert using (1) 8mm Hex Bolt, (1) 8mm Lock Washer and (1) 8mm Flat Washer (Figs 4 & 5). DO NOT tighten hardware at this time.

Driver/Left Side Installation Pictured

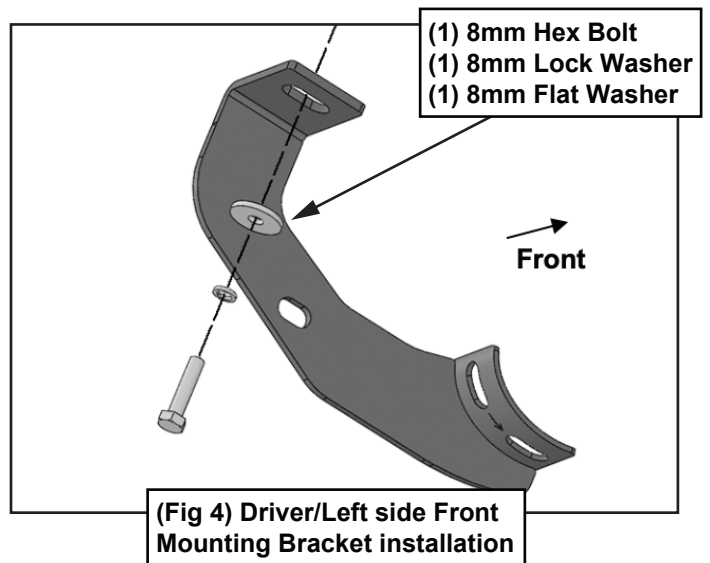
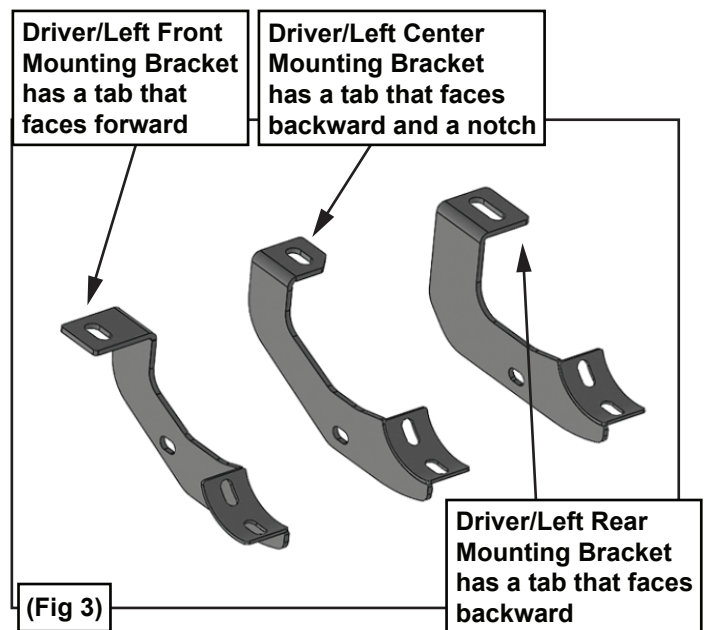

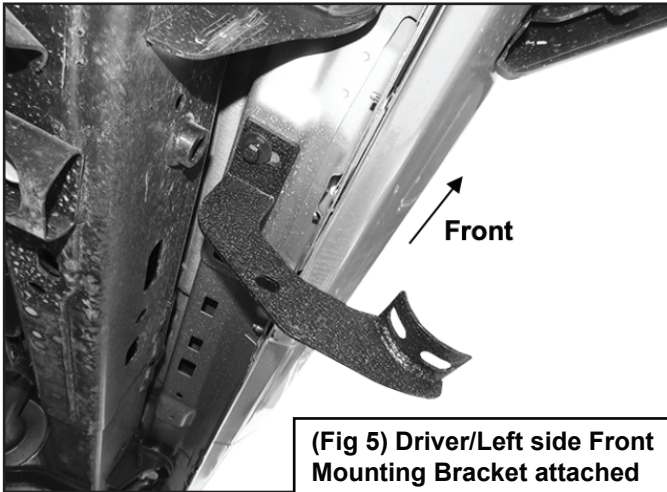

(Fig 5) Driver/Left side Front Mounting Bracket attached

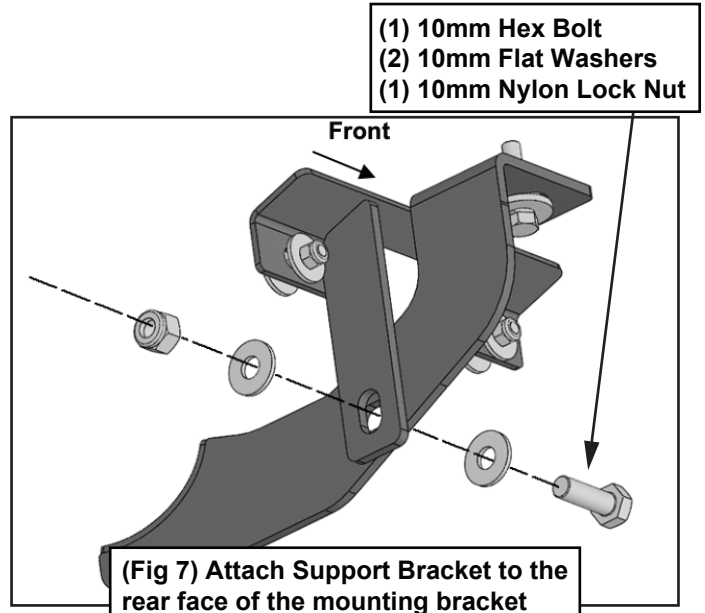

(Fig 7) Attach Support Bracket to the rear face of the mounting bracket

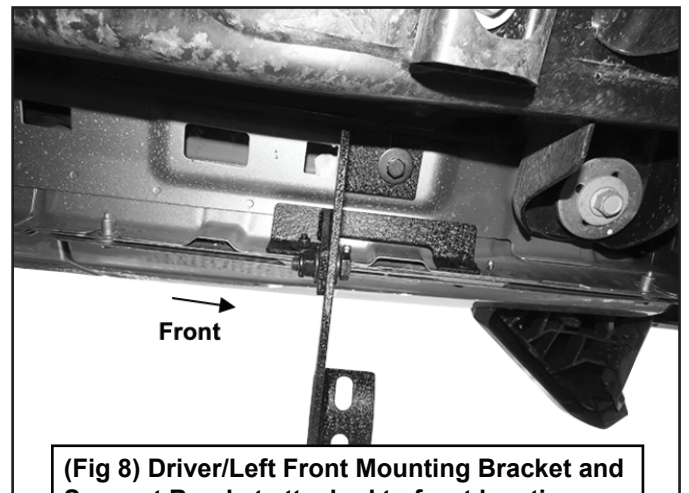

(Fig 8) Driver/Left Front Mounting Bracket and Support Bracket attached to front location

## STEP 4

Select the Driver/Left Front Support Bracket.

**IMPORTANT:** Use the illustration above to help identify the correct Support Bracket. Attach the Support Bracket to the pinch weld using (2) 6mm Hex Bolts, (4) 6mm Flat Washers and (2) 6mm Nylon Lock Nuts (Fig 6).

**NOTE:** Insert bolts from the outside of the pinch weld and through the Bracket. Attach the Support Bracket to the Mounting Bracket with (1) 10mm Hex Bolt, (2) 10mm Flat Washers and (1) 10mm Nylon Lock Nut (Figs 7 & 8). DO NOT tighten hardware at this time.

### Driver/Left Side Installation Pictured

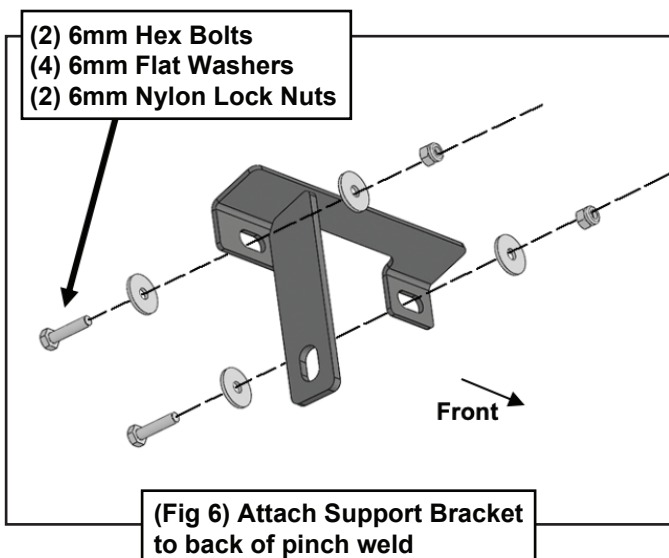

(Fig 6) Attach Support Bracket to back of pinch weld

## STEP 5

Move to the 2nd mounting location and locate the threaded insert and pair of holes in the pinch weld (Fig 9). Repeat **STEPS 3 & 4** to attach the Driver/Left Center Mounting and Support Brackets (Figs 3, 10—12).

**NOTE:** The Center and Rear **Mounting Brackets** look similar but the Center Bracket has an angled top tab.

The Center **Support Bracket** has a hole in the top is angled on the bottom tab. The Rear **Support Bracket** has a notch at the top (Fig 11). DO NOT tighten hardware at this time.

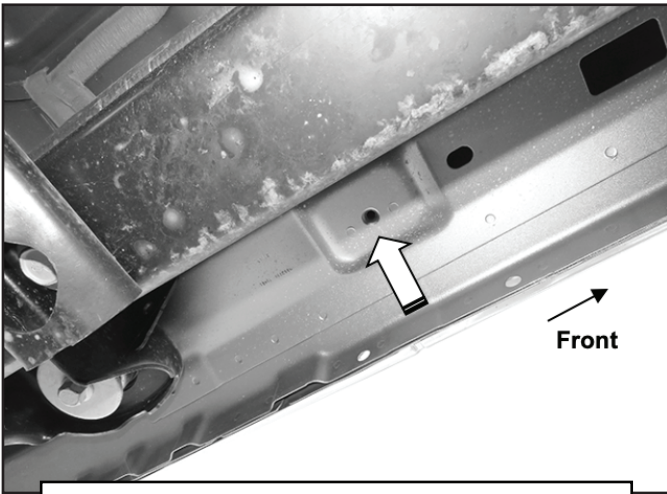

(Fig 9) Driver/Left side 2nd mounting location

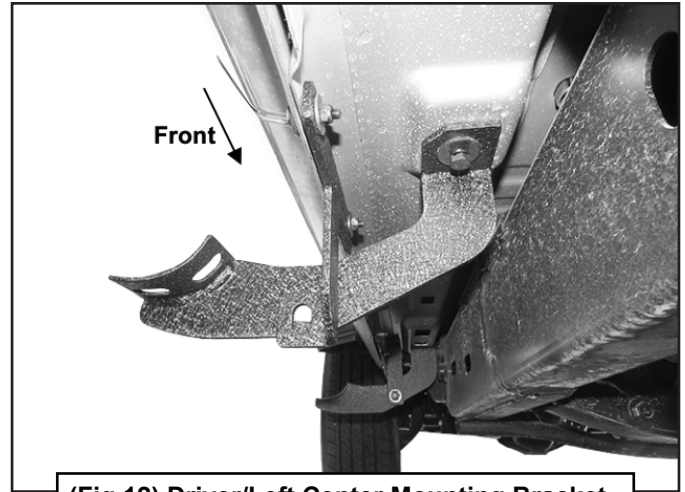

(Fig 12) Driver/Left Center Mounting Bracket and Support Bracket attached to 2nd location

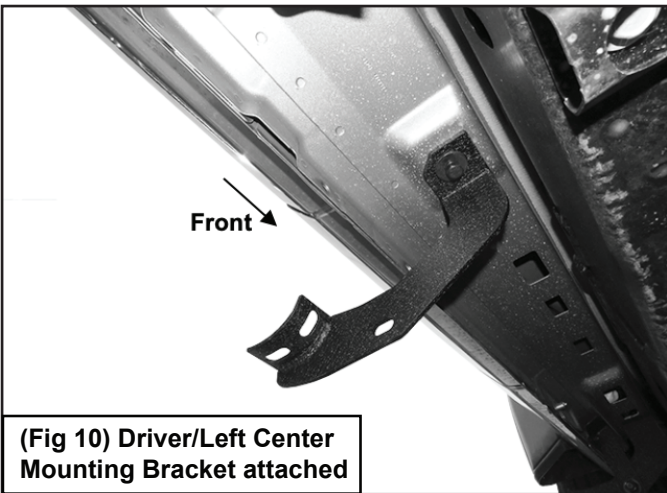

(Fig 10) Driver/Left Center Mounting Bracket attached

## STEP 6

Move to the last mounting location on the rocker panel and locate the threaded insert and pair of holes in the pinch weld (Fig 13). Repeat **STEPS 3 & 4** to attach the Driver/Left Rear Mounting and Support Brackets (Figs 3, 11 & 14). **DO NOT** tighten hardware at this time.

### Driver/Left Side Installation Pictured

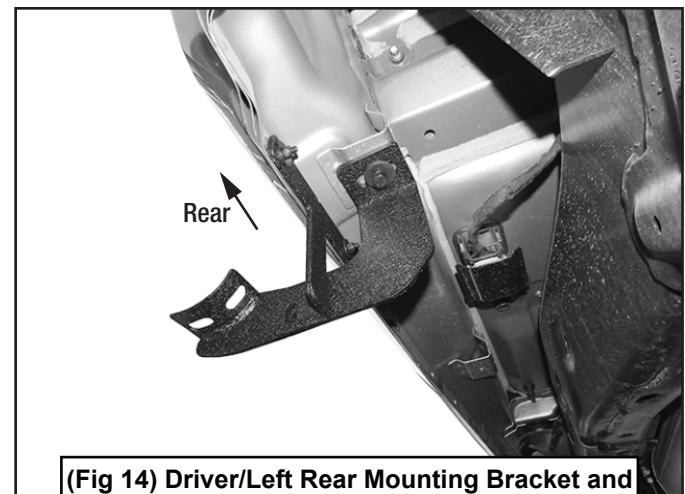
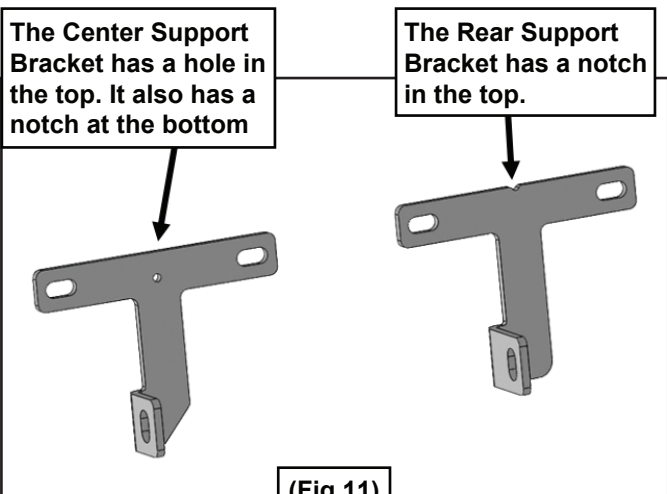

(Fig 14) Driver/Left Rear Mounting Bracket and Support Bracket attached to rear location



## STEP 7

Select the Driver/Left Sidebar. Use the illustration above to select the correct Sidebar. Carefully position the Sidebar onto the (3) Mounting Brackets.

**IMPORTANT:** DO NOT slide, (front to back or rotate), the Sidebar on the Brackets or damage to the finish on the Sidebar may result. Attach the Sidebar to the Mounting Brackets with (6) 8mm x 25mm Combo Bolts (Figs 15—18). DO NOT tighten hardware.

### Driver/Left Side Installation Pictured

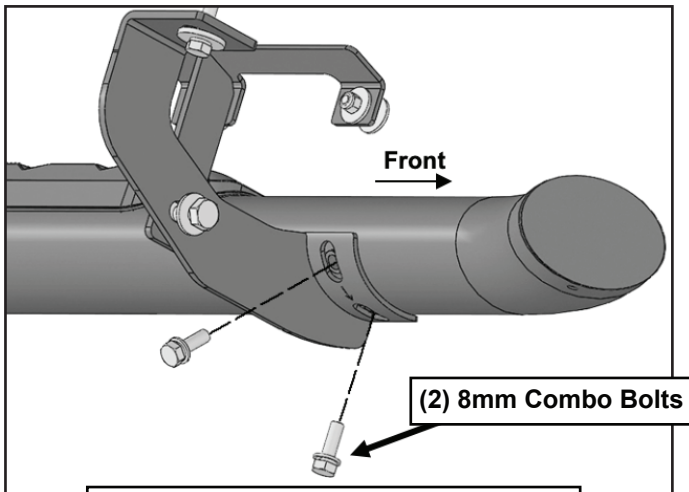

(Fig 15) Driver/Left Sidebar installation (Driver/Left front shown)

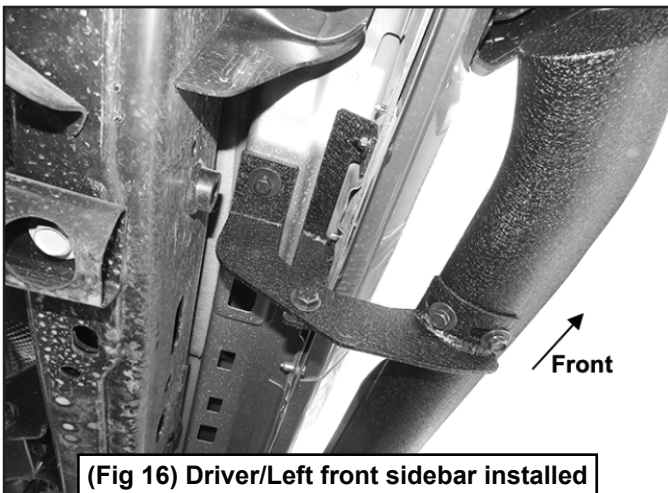

(Fig 16) Driver/Left front sidebar installed

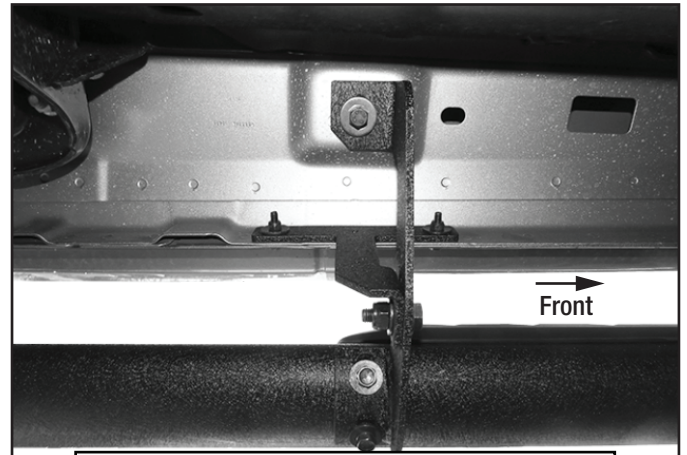

(Fig 17) Driver/Left center sidebar installed

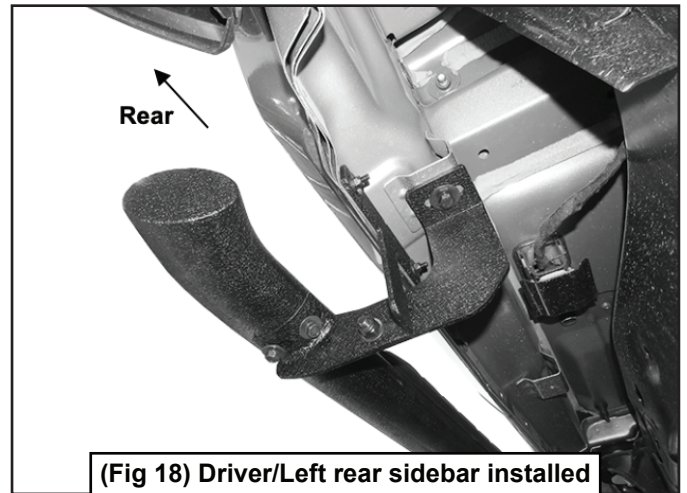

(Fig 18) Driver/Left rear sidebar installed

## STEP 8

Level and adjust the Sidebar and tighten all hardware.

## STEP 9

Repeat **STEPS 1—8** for Passenger/Right Sidebar installation.

## STEP 10

Do periodic inspections to the installation to make sure that all hardware is secure and tight.