



TYGER RIDER®

TG-SS2F35228

BEFORE INSTALLATION

READ INSTRUCTIONS CAREFULLY BEFORE STARTING INSTALLATION. REMOVE CONTENTS FROM BOX AND VERIFY ALL PARTS ARE PRESENT. FAILURE TO IDENTIFY DAMAGE BEFORE INSTALLATION COULD LEAD TO A REJECTION OF ANY CLAIM. IF MISSING PARTS OR ANY DAMAGE FOUND, PLEASE TAKE A PICTURE FOR THE CLAIM PURPOSE.

TORQUE VALUES

Fastener Size	Class 8.8 Torque (ft-lbs)	Class 10.9 Torque (ft-lbs)
6mm	6-7	6-7
8mm	15-16	22-23
10mm	31-32	44-45
12mm	54-55	78-79
14mm	87-88	125-126

Parts List

- x1 Driver/Left Tyger Rider
- x1 Passenger/Right Tyger Rider
- x4 Mounting Brackets
- x8 8-1.25mm x 25mm Combo Bolts
- x12 8mm x 24mm OD x 2mm Flat Washers
- x12 8mm Nylon Lock Nuts
- x12 8mm Plastic Washers

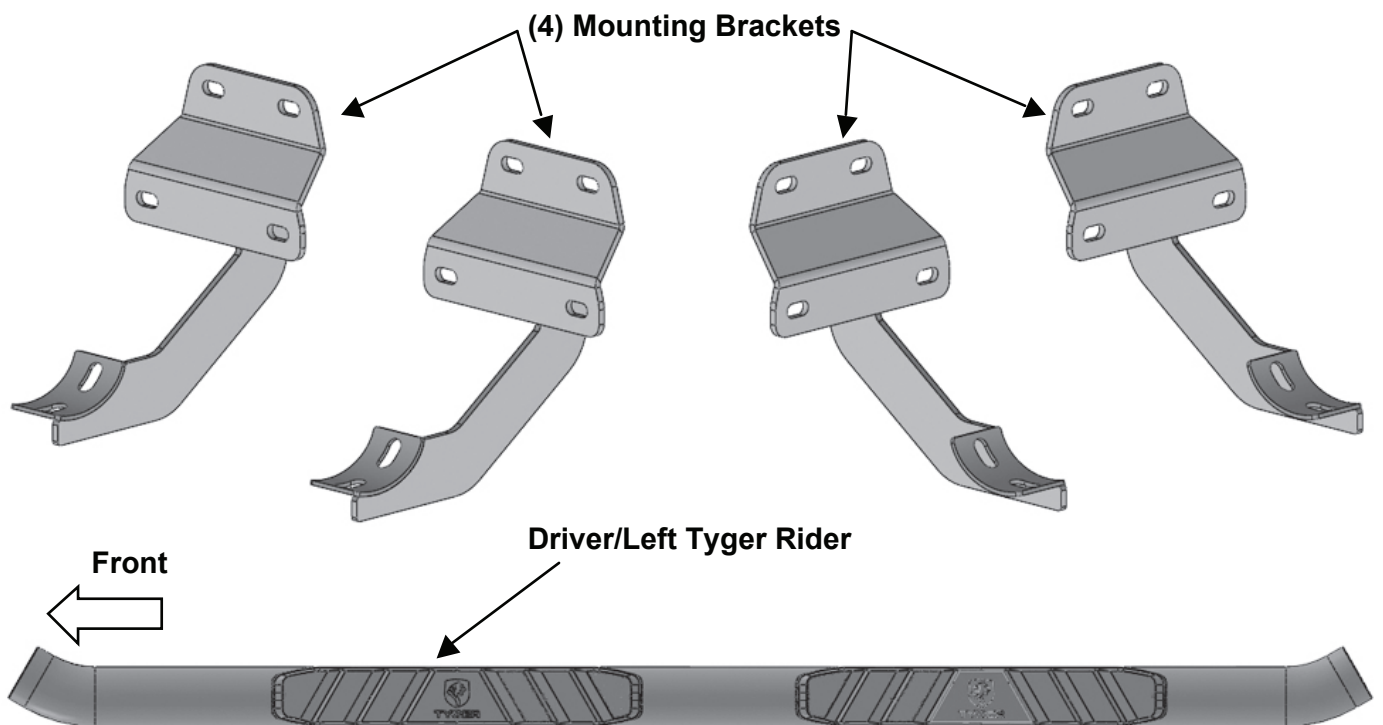



NOTE: REMOVE CONTENTS FROM BOX. VERIFY ALL PARTS ARE PRESENT. READ INSTRUCTIONS CAREFULLY BEFORE STARTING INSTALLATION. ASSISTANCE IS RECOMMENDED.

STEP 1

Start the installation under the Driver/Left side of the vehicle. Locate the front mounting location along the inner side of the body, (Fig 1).

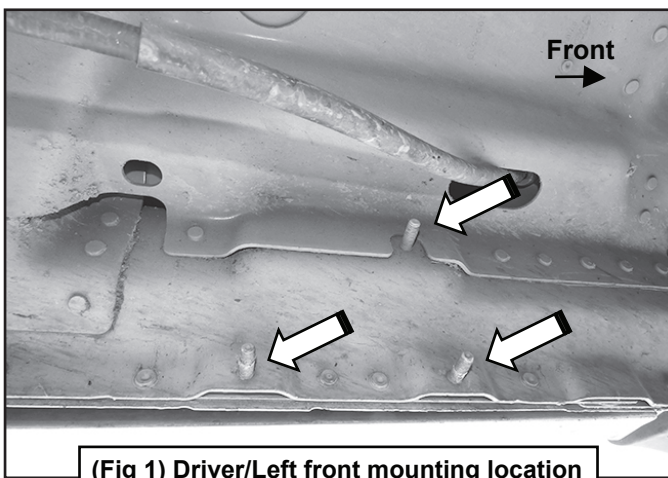

(Fig 1) Driver/Left front mounting location

STEP 2

Slide (1) Plastic Washer over each of the (3) factory mounting studs in the body panel, (Figs 2-3).

IMPORTANT: The Plastic Washers are designed to prevent corrosion between the aluminum body panel and the steel mounting brackets. Do not install the Brackets without the Plastic Washers.

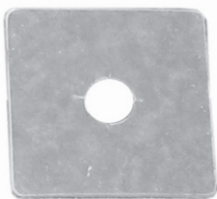

(Fig 2) Plastic Insulation Washer

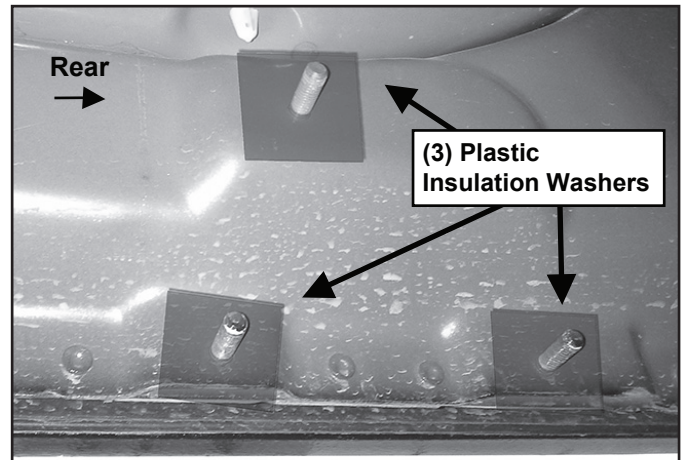
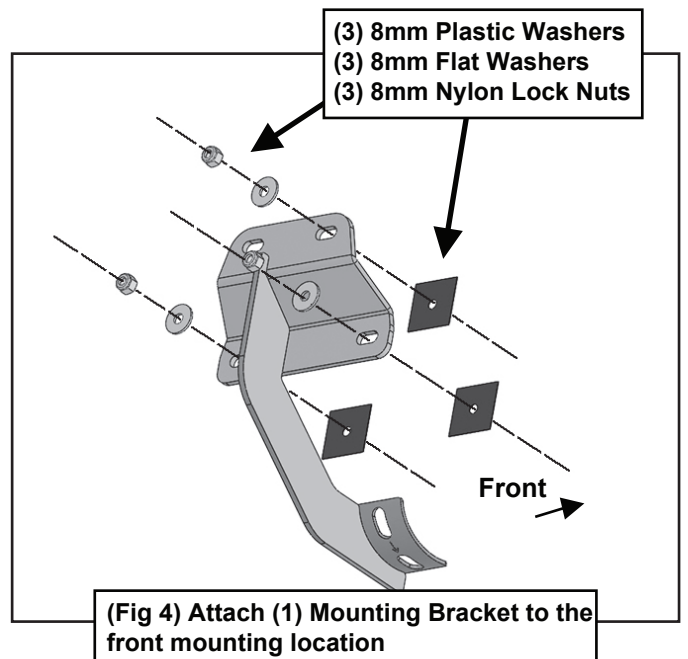

Fig 3) Thread Plastic Washers onto all mounting studs. (Passenger side rear mounting location pictured)

STEP 3

Select (1) Mounting Bracket.

NOTE: All (4) Brackets are universal and will fit left or right side. Attach the Mounting Bracket to the (3) factory studs with (3) 8mm Flat Washers and (3) 8mm Nylon Lock Nuts, (Figs 4-5). Leave brackets loose at this time.



(Fig 4) Attach (1) Mounting Bracket to the front mounting location

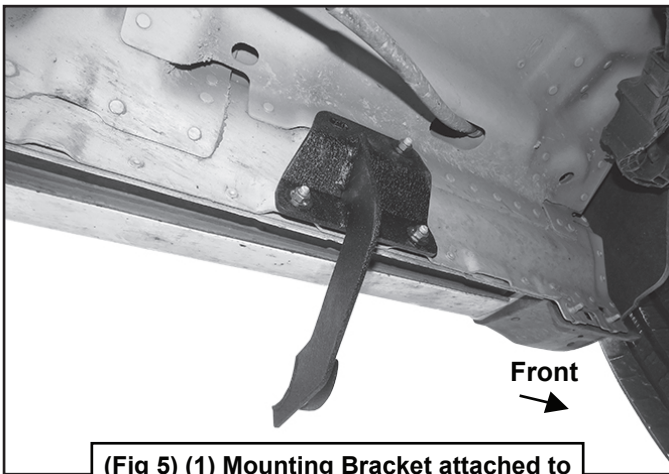

(Fig 5) (1) Mounting Bracket attached to the front location

STEP 4

Repeat Steps 1-3 to attach (1) Mounting Bracket to the rear location, (Figs 6-7).

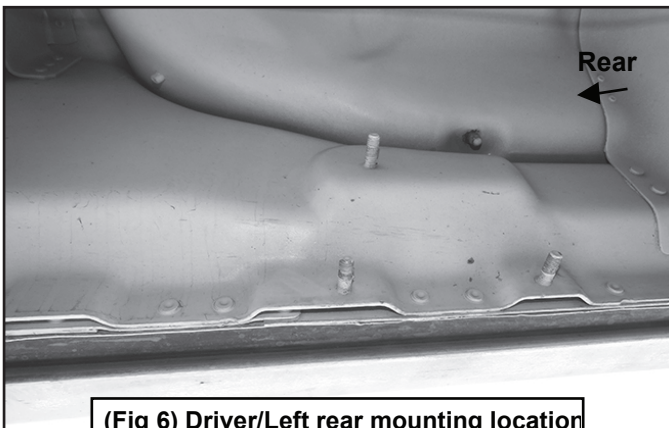

(Fig 6) Driver/Left rear mounting location

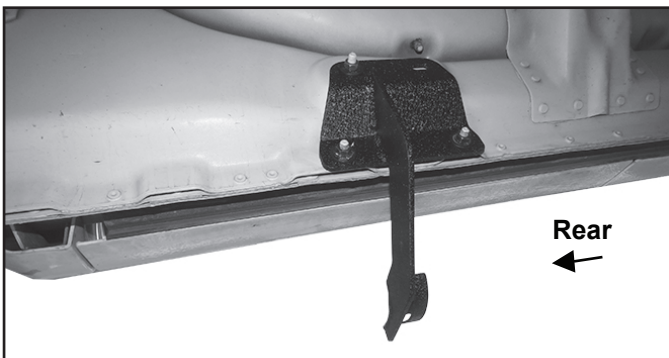

(Fig 7) (1) Mounting Bracket attached to the rear location

STEP 5

Select the Driver/Left Tyger Rider. Carefully place Sidebar on the brackets.

IMPORTANT: Do not slide or rotate Sidebar on cradles, or damage to the finish may result. Attach Sidebar to the Mounting Brackets with (6) 8mm Combo Bolts, (Fig 8). Do not tighten hardware at this time.

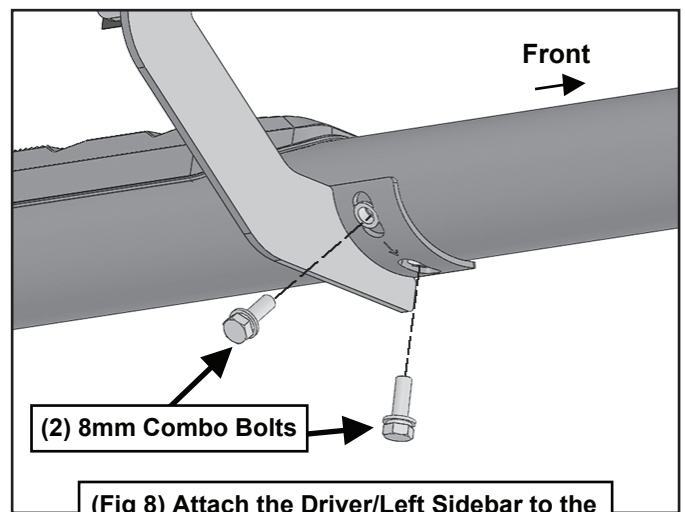

(Fig 8) Attach the Driver/Left Sidebar to the Mounting Brackets

STEP 6

Level and adjust the Sidebar and tighten all hardware.

STEP 7

Repeat Steps 1-6 to attach the Passenger/Right Tyger Rider.

STEP 8

Do periodic inspections to the installation to make sure that all hardware is secure and tight.