



## TYGER RIDER®

TG-SS2C35168

### BEFORE INSTALLATION

READ INSTRUCTIONS CAREFULLY BEFORE STARTING INSTALLATION. REMOVE CONTENTS FROM BOX AND VERIFY ALL PARTS ARE PRESENT. FAILURE TO IDENTIFY DAMAGE BEFORE INSTALLATION COULD LEAD TO A REJECTION OF ANY CLAIM. IF MISSING PARTS OR ANY DAMAGE FOUND, PLEASE TAKE A PICTURE FOR THE CLAIM PURPOSE.

### TORQUE VALUES

Fastener Size	Class 8.8 Torque (ft-lbs)	Class 10.9 Torque (ft-lbs)
6mm	6-7	6-7
8mm	15-16	22-23
10mm	31-32	44-45
12mm	54-55	78-79
14mm	87-88	125-126

### Parts List

- x1 Driver/Left Tyger Rider
- x1 Passenger/Right Tyger Rider
- x6 Mounting Brackets
- x12 8-1.25mm x 25mm Hex Bolts
- x12 8-1.25mm x 25mm Combo Hex Bolts
- x12 8mm Lock Washers
- x12 8mm x 24mm OD x 2mm Flat Washers
- x12 8mm Clip Nuts

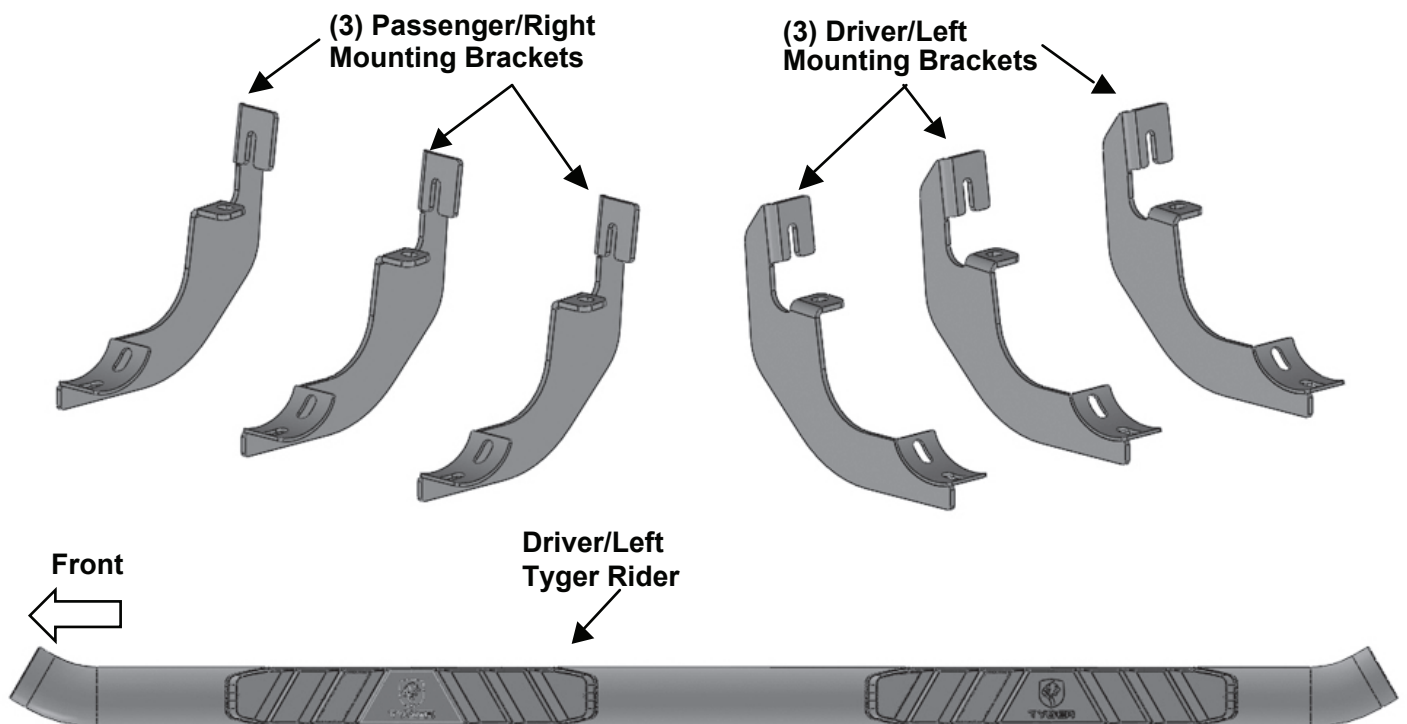



**NOTE:** REMOVE CONTENTS FROM BOX. VERIFY ALL PARTS ARE PRESENT. READ INSTRUCTIONS CAREFULLY BEFORE STARTING INSTALLATION. ASSISTANCE IS RECOMMENDED.

## STEP 1

Start the installation under the Driver/Left side of the vehicle. Locate the front mounting location along the bottom and inner side of the body panel, (Figs 1-2). Installation will use the 1st, 2nd and 4th mounting locations, (Fig 1).

**NOTE:** It may help to hold a Bracket up in place to help determine the mounting holes to use along the bottom and inner side of the body.

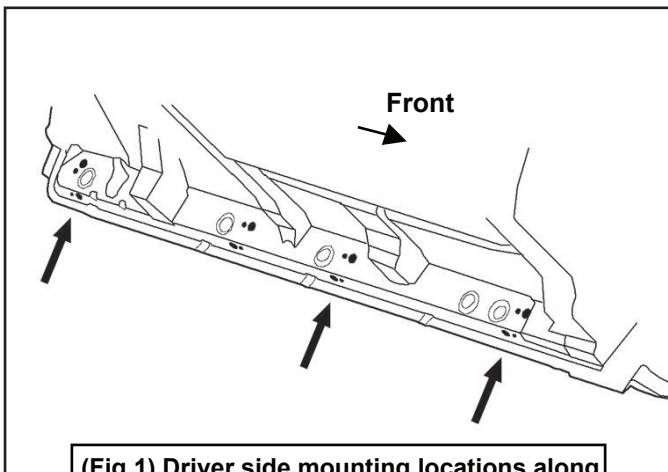

(Fig 1) Driver side mounting locations along bottom and back of body panel illustrated

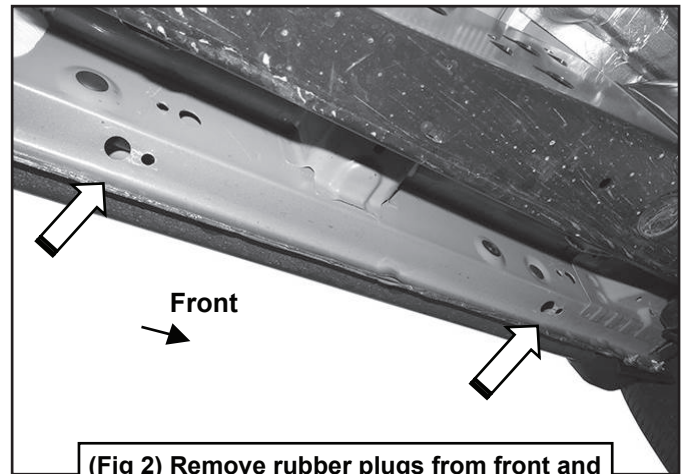

(Fig 2) Remove rubber plugs from front and center mounting locations (arrows)

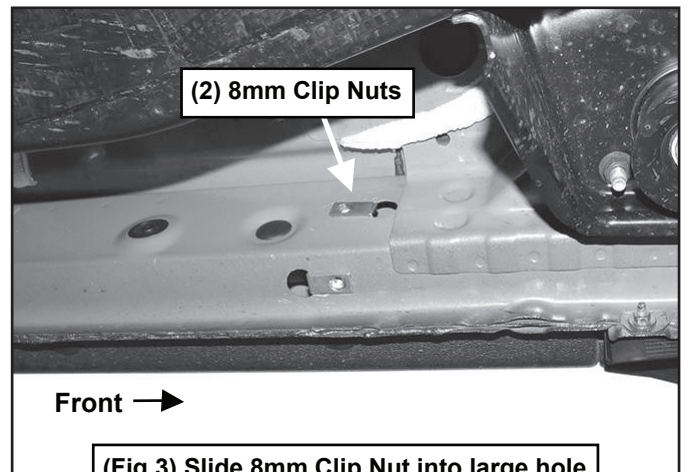

(Fig 3) Slide 8mm Clip Nut into large hole and over small hole

## STEP 2

Remove rubber plugs from the front location, (Fig 2). Select (2) 8mm Clip Nuts. Slide each Clip Nut into the large hole and over the smaller hole next to it. Line up threaded nut on the Clip Nut with smaller hole in body panel, (Fig 3).

## STEP 3

Select (1) Driver/Left Mounting Bracket. Attach the Bracket to the (2) Clip Nuts with (2) 8mm Hex Bolts, (2) 8mm Lock Washers and (2) 8mm Flat Washers, (Fig 4). Do not tighten hardware.

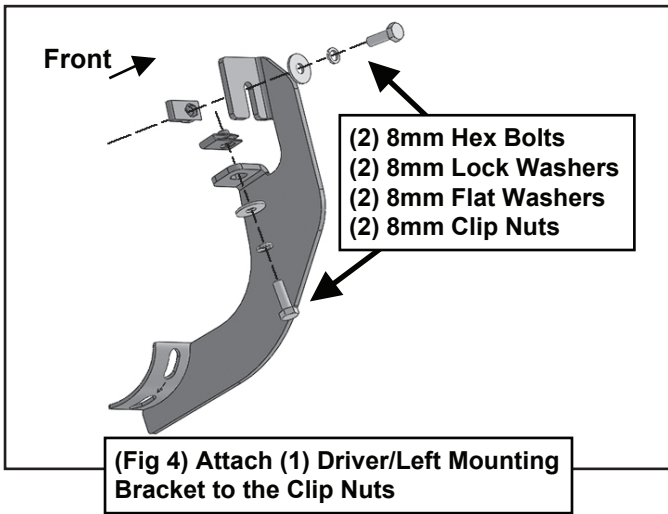

## STEP 4

Repeat Steps 1-3 to attach the remaining (2) Driver/Left Mounting Brackets to the 2nd and rear locations, (Figs 1, 2, 4 & 5). Do not tighten hardware.

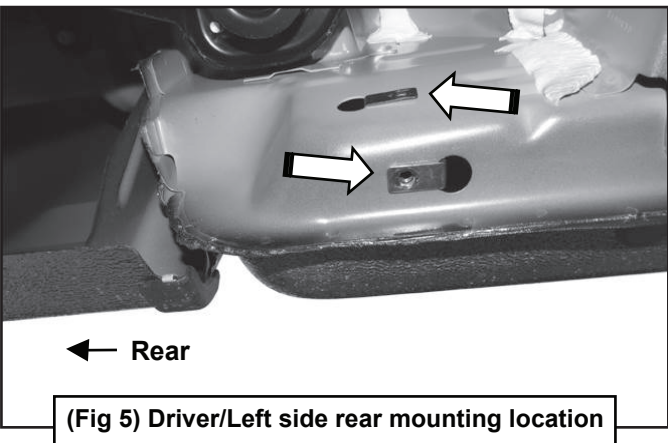

## STEP 5

Select the Driver/Left Side Tyger Rider. Carefully place Sidebar on the brackets.

**IMPORTANT:** Do not slide or rotate Sidebar on cradles, or else damage to the finish may result. Attach Sidebar to the Mounting Brackets with (6) 8mm Combo Bolts, (Fig 6). Do not tighten hardware at this time.

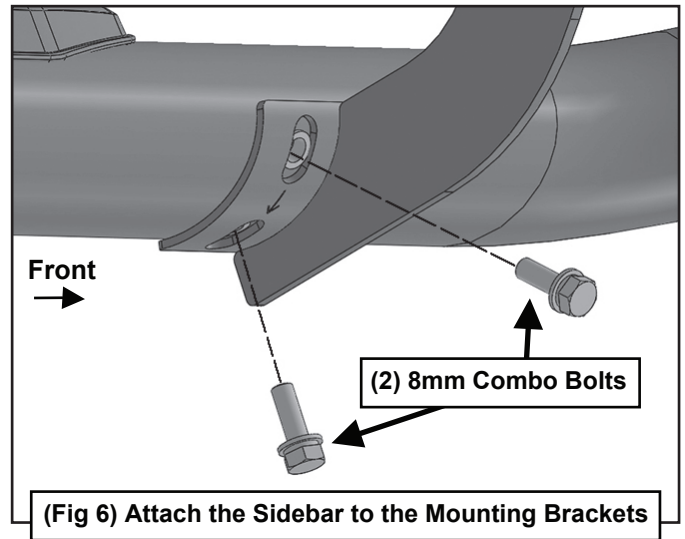

## STEP 6

Level and adjust the Sidebar and tighten all hardware.

## STEP 7

Repeat Steps 1-6 to attach the Passenger/Right Tyger Rider.

## STEP 8

Do periodic inspections to the installation to make sure that all hardware is secure and tight.