



# STEP BARS

TG-SS2C35018

## BEFORE INSTALLATION

READ INSTRUCTIONS CAREFULLY BEFORE STARTING INSTALLATION. REMOVE CONTENTS FROM BOX AND VERIFY ALL PARTS ARE PRESENT. FAILURE TO IDENTIFY DAMAGE BEFORE INSTALLATION COULD LEAD TO A REJECTION OF ANY CLAIM. IF MISSING PARTS OR ANY DAMAGE FOUND, PLEASE TAKE A PICTURE FOR THE CLAIM PURPOSE.

## TORQUE VALUES

Fastener Size	Class 8.8 Torque (ft-lbs)	Class 10.9 Torque (ft-lbs)
6mm	6-7	6-7
8mm	15-16	22-23
10mm	31-32	44-45
12mm	54-55	78-79
14mm	87-88	125-126

## Parts List

- x1 Driver/Left Sidebar
- x1 Passenger/Right Sidebar
- x1 Passenger/right Front Upper Bracket (all incl. DEF)
- x1 Passenger/right Front Lower Bracket (all incl. DEF)
- x5 Mounting Brackets (use for left or right)
- x1 8-1.25mm Bolt Plate
- x11 8-1.25mm Clip-On Nuts
- x13 8-1.25mm x 25mm Hex Bolts
- x13 8mm x 24mm x 2mm Flat Washers
- x13 8mm Lock Washers
- x1 8mm Nylon Lock Nut
- x12 8-1.25mm x 25mm Combo Hex Bolts

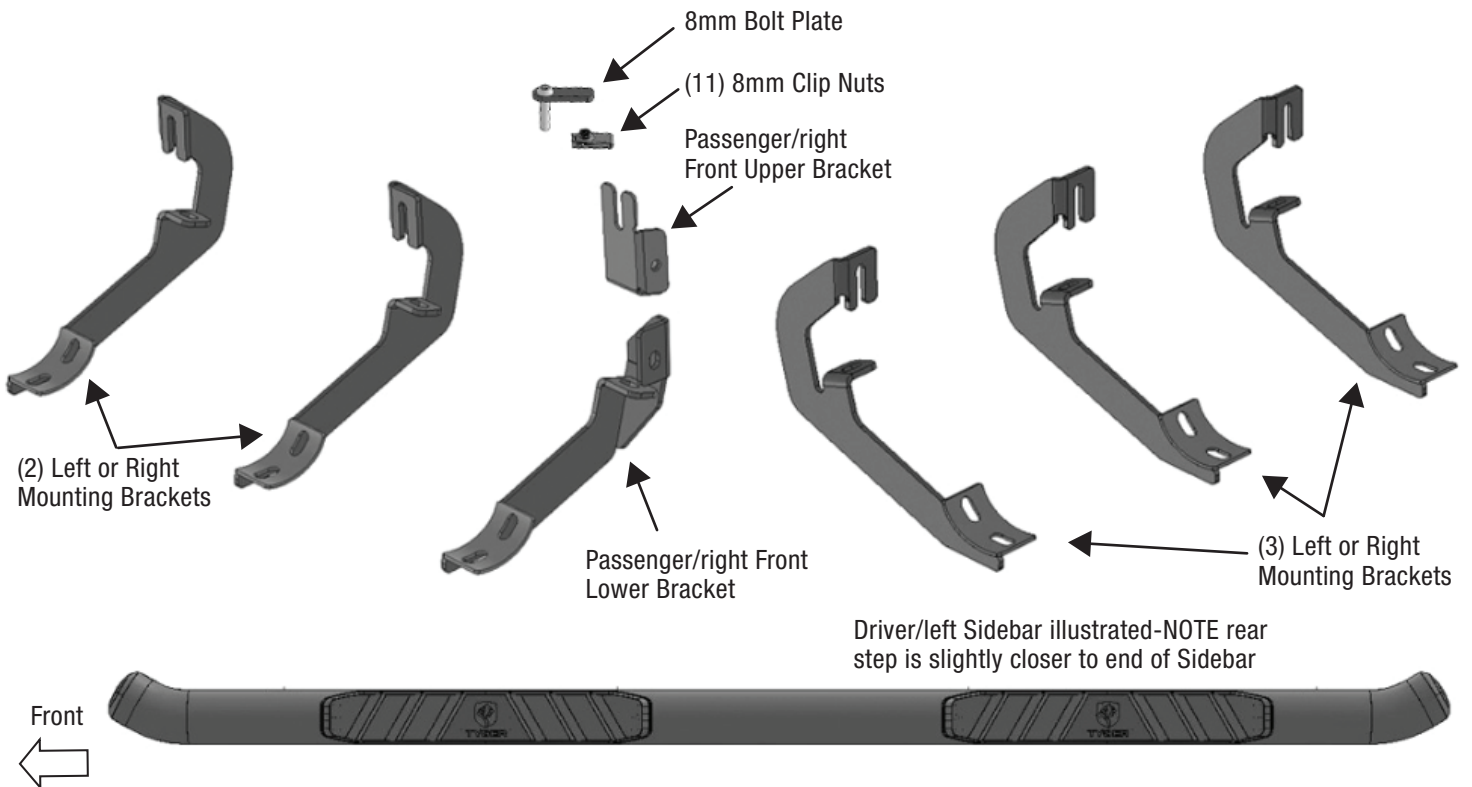



## PROCEDURE:

REMOVE CONTENTS FROM BOX. VERIFY ALL PARTS ARE PRESENT. READ INSTRUCTIONS CAREFULLY BEFORE STARTING INSTALLATION. ON MODELS WITH DEF TANK, SELECT A FLAT, LEVEL AREA FOR INSTALLATION. MAY REQUIRE CUTTING.

## STEP 1

Start the installation under the driver/left side of the vehicle. Locate the 5 tabs along the bottom edge of the body, (pinch weld). Mounting Brackets will attach to 1st, 2nd, (just in front of center of cab), and 5th mounting tabs, (Fig 1). Directly above each tab is a top mounting location on the side of the body panel. Hold a Bracket up in place to help determine the mounting holes to use along the body.

### Driver/Left Side Installation Pictured

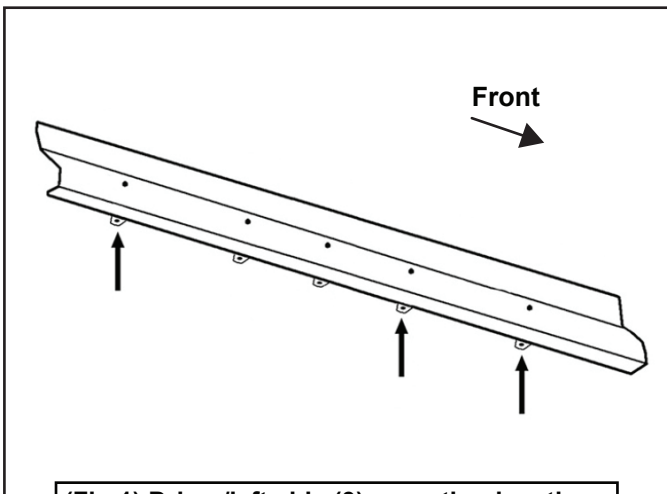

(Fig 1) Driver/left side (3) mounting locations

## STEP 2

Determine the correct procedure for your model year and each Bracket location.

### Bottom mounting location on the edge of the pinch weld.

- **Flat tab on pinch weld with factory installed weld nut:**  
Thread hex bolt into weld nut from the backside-down to clear paint from threads, (Fig 2).

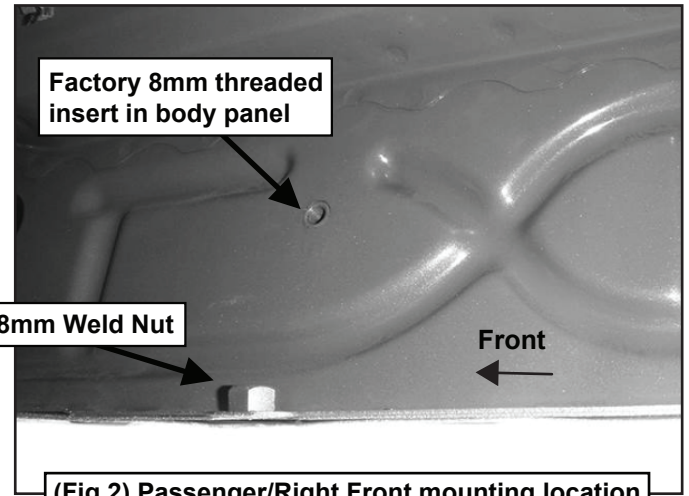

(Fig 2) Passenger/Right Front mounting location

### • Flat tab on pinch weld with hole:

Select (1) 8mm Clip Nut. Slide the Clip Nut over the tab with the nut facing up behind the tab, (Figs 3—5, 7). Line up threaded nut with hole in the tab. Repeat for each mounting location.

### Driver/Left Side Installation Pictured

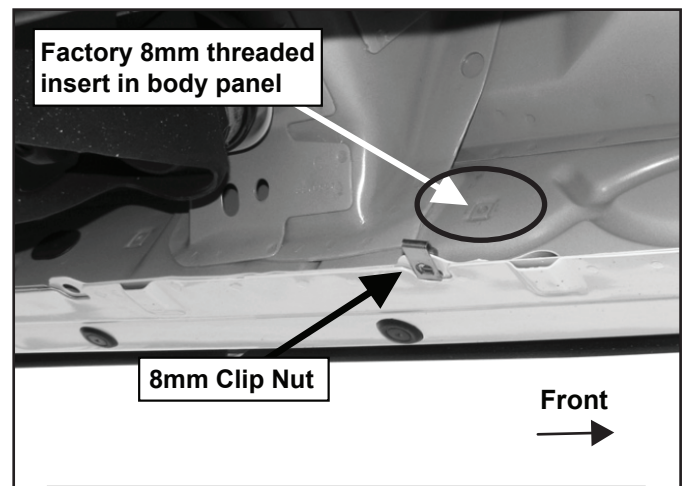

(Fig 3) Driver/left side center mounting location

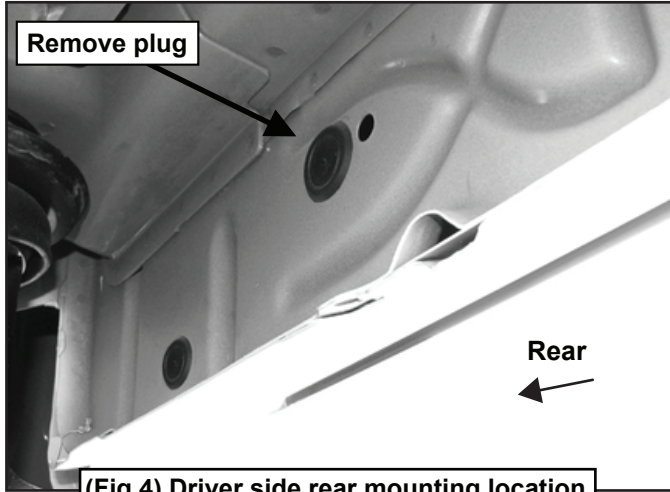

(Fig 4) Driver side rear mounting location

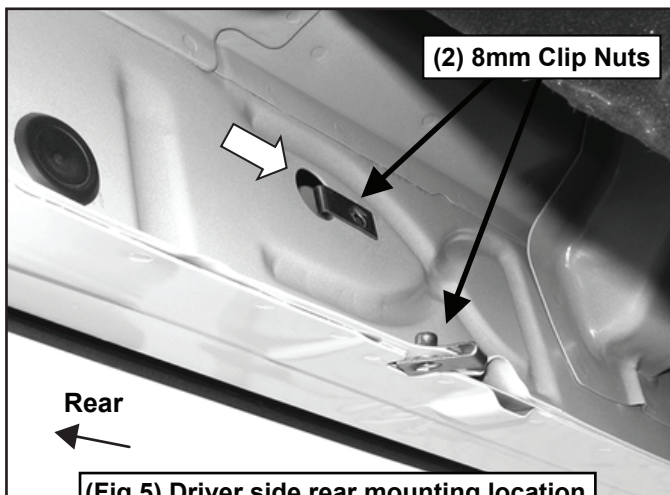

(Fig 5) Driver side rear mounting location

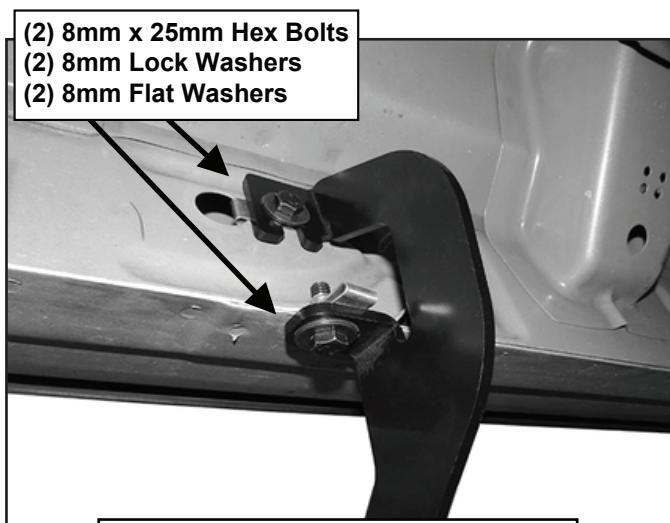

(Fig 7) Driver/left rear bracket installed

**Locate top mounting location on the back side of the body panel.**

- **Models with factory installed threaded insert in body panel:**  
Thread 8mm Hex Bolt into threaded insert to clear paint as required, (Fig 2 & 3).
- **Large and small hole in side of body panel:**  
Remove the rubber plug from the larger hole, (Fig 4). Select (1) 8mm Clip Nut. Slide the Clip Nut into the larger hole. Line up the threaded nut with the smaller hole, (Fig 5).

## STEP 3

Select (1) Mounting Bracket.

**NOTE:** (5) Brackets are universal and will fit all left and the center and rear locations on the passenger/right side. See illustration above to help determine correct Bracket. Attach the Mounting Bracket to the Clip Nuts and/or the factory threaded holes with (2) 8mm Hex Bolts, (2) 8mm Lock Washers and (2) 8mm Flat Washers, (Figs 6 & 7). DO NOT tighten hardware.

**Driver/Left Side Installation Pictured**

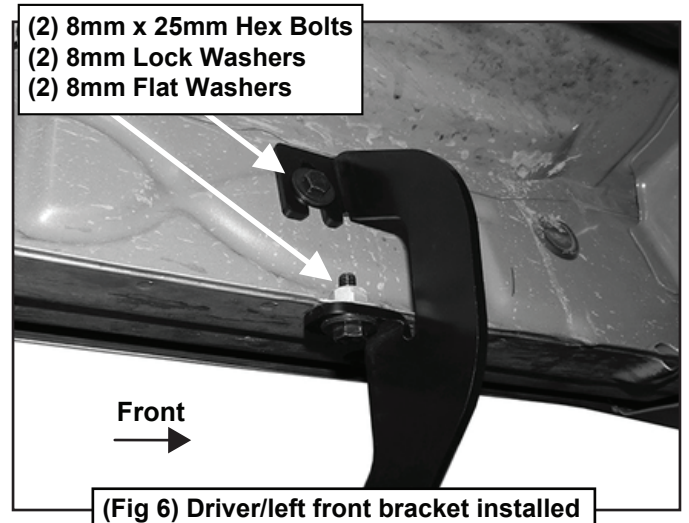

(Fig 6) Driver/left front bracket installed



## STEP 4

Move to the 2nd mounting location along the body panel and repeat **STEPS 2 & 3** to install the center Bracket.

## STEP 5

Continue along the cab to the rear mounting location. Repeat **STEPS 2—4** to install the driver/left side rear Bracket, (Fig 7).

## STEP 6

Select the Driver/left Sidebar. Carefully position the Sidebar onto the (3) Mounting Brackets.

**IMPORTANT:** DO NOT slide, (front to back or rotate), the Sidebar on the Brackets or damage to the finish may result. Attach the Sidebar to the (3) Brackets with (6) 8mm Combination Hex Bolts, (Fig 8). DO NOT fully tighten at this time.

Driver/Left Side Installation Pictured

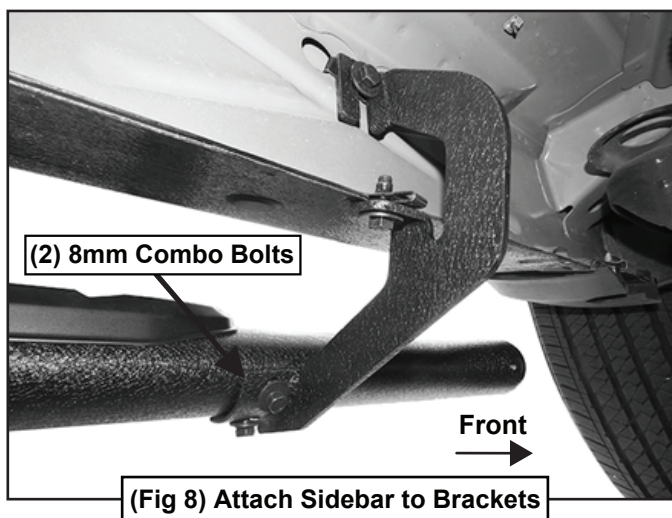

## STEP 7

Level and adjust the Sidebar and fully tighten all hardware

## STEP 8

Move to the passenger side of the vehicle. Determine if the vehicle is equipped with a plastic diesel exhaust fluid (DEF) tank, (Figs 10 & 11).

**Models without DEF tank, skip to STEP 9.**

**Models with DEF tank:** The tank sits close to the side of the body. With specialized tools, the passenger front upper and lower Bracket can be installed but room is very limited. Determine model year of vehicle before proceeding.

**Up to 2016 models:**

It may be easier to drop the tank down to access the inner side panel for upper Bracket installation. Tank will not need to be removed, only dropped down for access to mounting location.

**IMPORTANT:** If tank is full, it will be very heavy and assistance is highly recommended to avoid injury or damage to the vehicle or the tank. It is recommended that installation is performed when the DEF tank is low on fluid before dropping the tank.

**a.** On models with plastic lower tray under the tank, remove the (3) hex bolts attaching the tray to the frame, (Fig 9), and remove the tray.

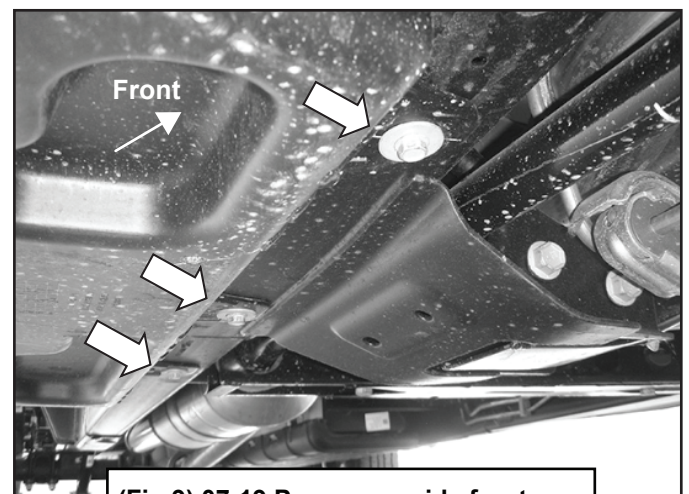



b. Release the tank filler hose. Release the plug for the sending unit on the top of the tank.

c. Support the tank with a floor jack. Place a smooth flat surface, (wooden block for example), between the floor jack and the tank to avoid damaging the plastic tank. DO NOT push up on the tank; only support the weight of the tank with the jack.

d. Remove the (2) bolts securing the tank straps to the vehicle, (Fig 10). Tilt the straps to release from the brackets. Slowly lower the tank until the top of the tank is almost visible. Use blocks or stands to support the tank while installing the front Upper and Lower Brackets.

### Driver/Left Side Installation Pictured

Remove (2) factory bolts to remove tank straps

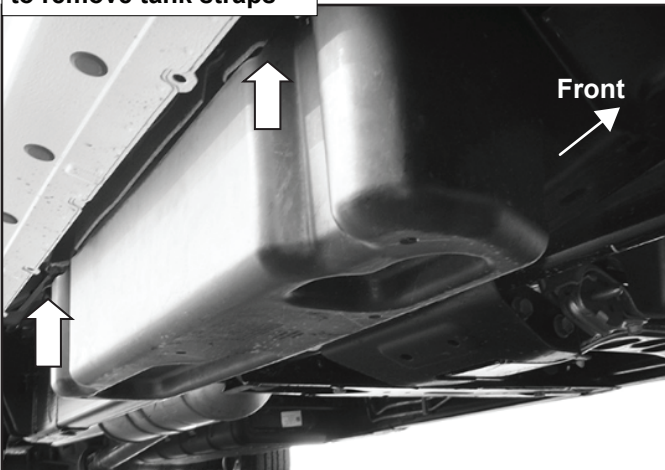

(Fig 10) 07-16 Passenger side DEF tank and cover

e. Proceed to **STEP 9**.

### On 2017-on models:

a. Remove the (4) hex bolts attaching plastic cover to DEF tank, (Fig 11) and remove plastic cover, (Fig 19).

**NOTE:** On 2017-on 25-3500 models, only remove plastic cover from DEF tank. DO NOT lower or remove the DEF tank and proceed to **STEP 9**.

### Driver/Left Side Installation Pictured

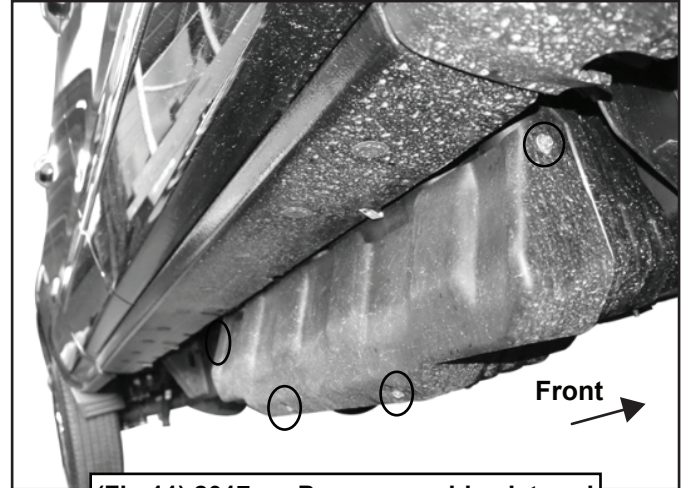

(Fig 11) 2017-on Passenger side pictured with DEF plastic tank cover. Remove (4) hex bolts to remove plastic cover

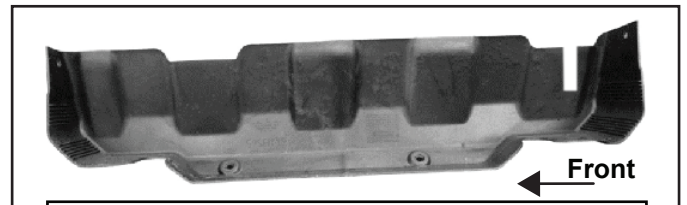

(Fig 19) 2017-on DEF cover cut for example only

## STEP 9

Locate the first tab on the edge of the pinch weld. Select the Upper Bracket, (Fig 12). Repeat **STEPS 2 & 3** to attach the top of the passenger/right front Upper Bracket to the side of the body panel, (Fig 13). DO NOT tighten hardware at this time.

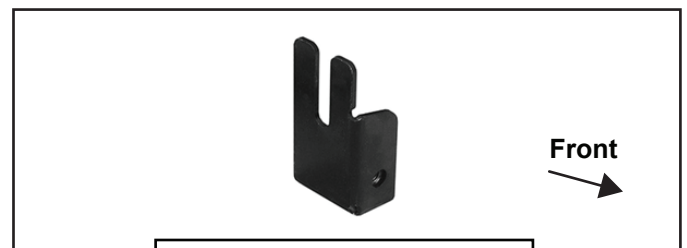

(Fig 12) Passenger/right Front Upper Bracket (all models)

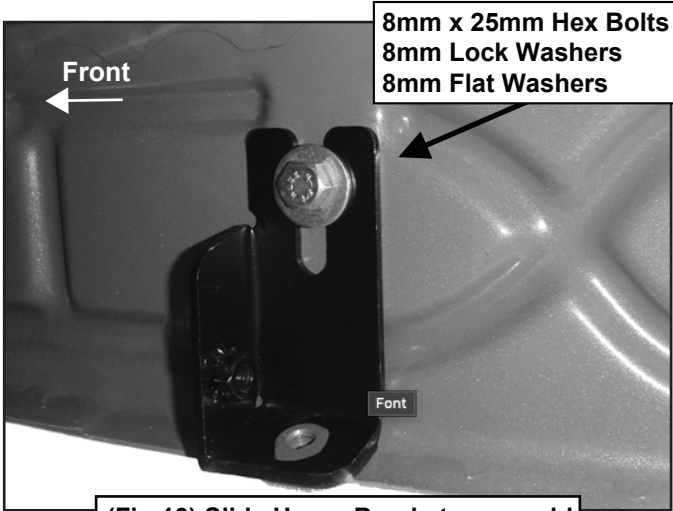

(Fig 13) Slide Upper Bracket over weld nut if equipped-also see Figure 2

**b. Models with flat tab and hole:** Insert the 8mm Bolt Plate down through the hole in the Upper Bracket and mounting tab, (Figs 14 & 15). Attach the Lower Bracket to the bottom of the body and Bolt Plate with (1) 8mm Flat Washer and (1) 8mm Nylon Lock Nut, (Fig 16). Leave loose at this time.



(Fig 14) 8mm x 35mm Bolt Plate

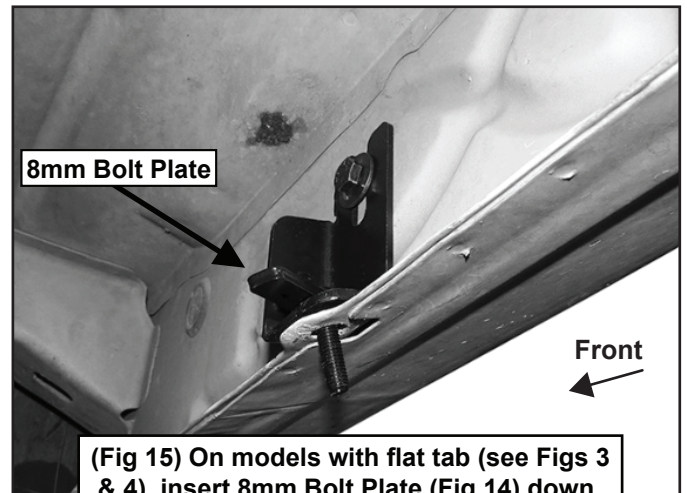

(Fig 15) On models with flat tab (see Figs 3 & 4), insert 8mm Bolt Plate (Fig 14) down through Upper Bracket and mounting tab

## STEP 10

Line up the hole in the bottom of the Upper Bracket with the hole in the tab on the pinch weld.

**a. Models with a weld-nut:** Slide the Bracket over the weld-nut, (Fig 13). Attach the Lower Bracket to the bottom of the body and weld-nut with (1) 8mm x 25mm Hex Bolt, (1) 8mm Lock Washer and (1) 8mm Flat Washer, (Fig 16). Leave loose at this time.

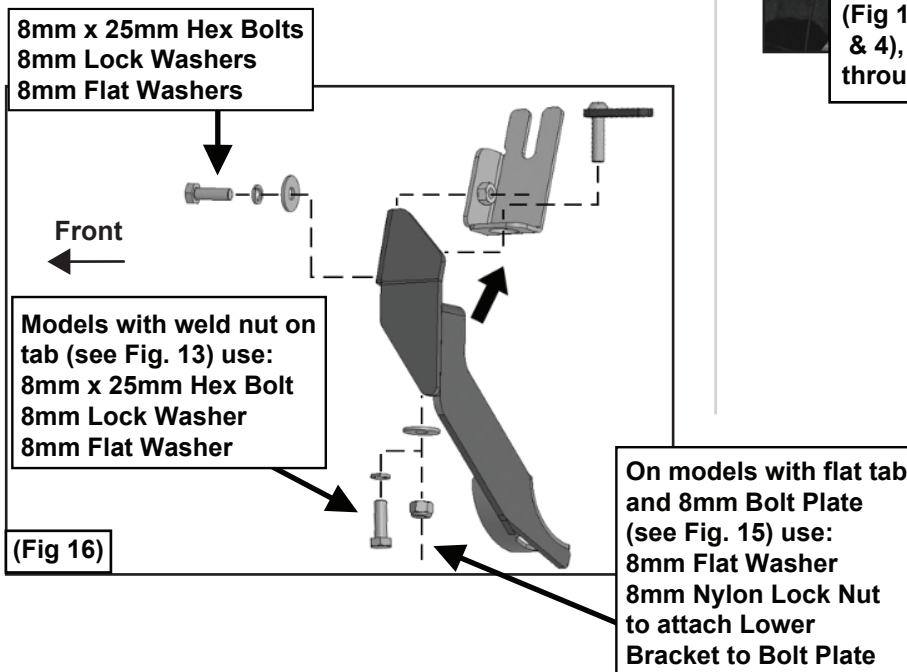



## STEP 11

Attach the Lower Bracket to the side of the Upper Bracket with (1) 8mm x 25mm Hex Bolt, (1) 8mm Lock Washer and (1) 8mm Flat Washer, (Figs 16 & 20). Leave loose at this time.

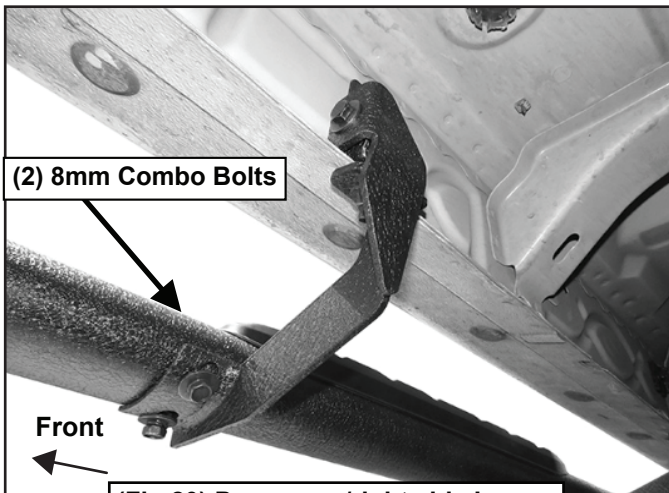

(2) 8mm Combo Bolts

Front

(Fig 20) Passenger/right side Lower Bracket attached to Upper Bracket

## STEP 12

Repeat **STEPS 1—4** to install the passenger side center, (Fig 17), and rear Brackets.

**NOTE:** Cradles on Brackets installed on passenger side will face forward.

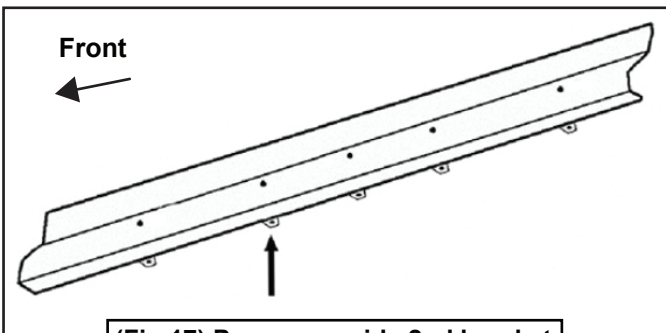

(Fig 17) Passenger side 2nd bracket location from back of body panel

a. **2017-on 25-3500 DEF tank models:** Hold the DEF cover in place and mark the center Bracket location onto the cover, (Fig 18). Use a sharp knife or hacksaw blade to carefully cut a slot in the plastic cover to clear the center Bracket as necessary, (Fig 19). Remove as little plastic as possible.

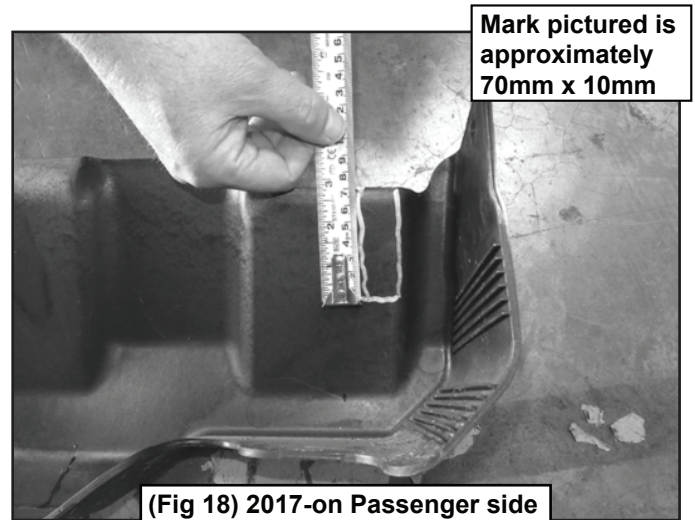

Mark pictured is approximately 70mm x 10mm

(Fig 18) 2017-on Passenger side DEF cover marked for trimming

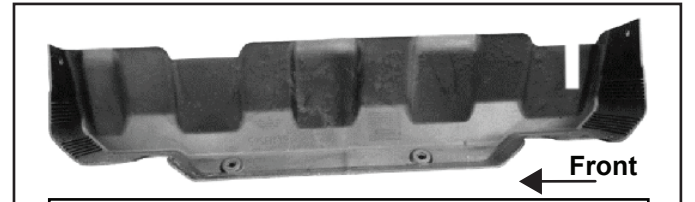

(Fig 19) 2017-on DEF cover cut for example only

## STEP 13

Repeat **STEPS 6 & 7** to install the passenger/right Sidebar, (Fig 20).

## STEP 14

Once the Sidebar has been installed and all hardware fully tightened, reinstall the DEF tank and cover, if equipped, as described in **STEPS 8 & 12**.



# TYGER<sup>®</sup>

## STEP 15

Do periodic inspections to the installation to make sure that all hardware is secure and tight.

