



RISER™

TG-RS9D50078&TG-RS9D50077

BEFORE INSTALLATION

READ INSTRUCTIONS CAREFULLY BEFORE STARTING INSTALLATION. REMOVE CONTENTS FROM BOX AND VERIFY ALL PARTS ARE PRESENT. FAILURE TO IDENTIFY DAMAGE BEFORE INSTALLATION COULD LEAD TO A REJECTION OF ANY CLAIM. IF MISSING PARTS OR ANY DAMAGE FOUND, PLEASE TAKE A PICTURE FOR THE CLAIM PURPOSE.

TORQUE VALUES

Fastener Size	Class 8.8 Torque (ft-lbs)	Class 10.9 Torque (ft-lbs)
6mm	6-7	6-7
8mm	15-16	22-23
10mm	31-32	44-45
12mm	54-55	78-79
14mm	87-88	125-126

PARTS LIST

- x1** Driver/left Sidebar
- x1** Passenger/right Sidebar
- x3** DS Front & PS Center/Rear Brackets
- x3** PS Front & DS Center/Rear Brackets
- x6** Plastic Covers
- x12** Plastic Retaining Clips
- x12** 8-1.25mm x 30mm Hex Bolts
- x12** 8-1.25mm x 25mm Combo Bolts
- x6** 8mm Nut/Bolt Plates
- x6** 8mm Plastic Retainers
- x12** 8mm Lock Washers
- x12** 8mm x 24mm x 2mm Flat Washers
- x6** 8-1.25mm Hex Nuts
- x12** 6-1.0mm x 25mm Button Head Bolts
- x24** 6mm x 18mm x 1.6mm Flat Washers
- x12** 6mm Flange Nuts
- x1** Allen Wrench S=4 (6mm hardware)

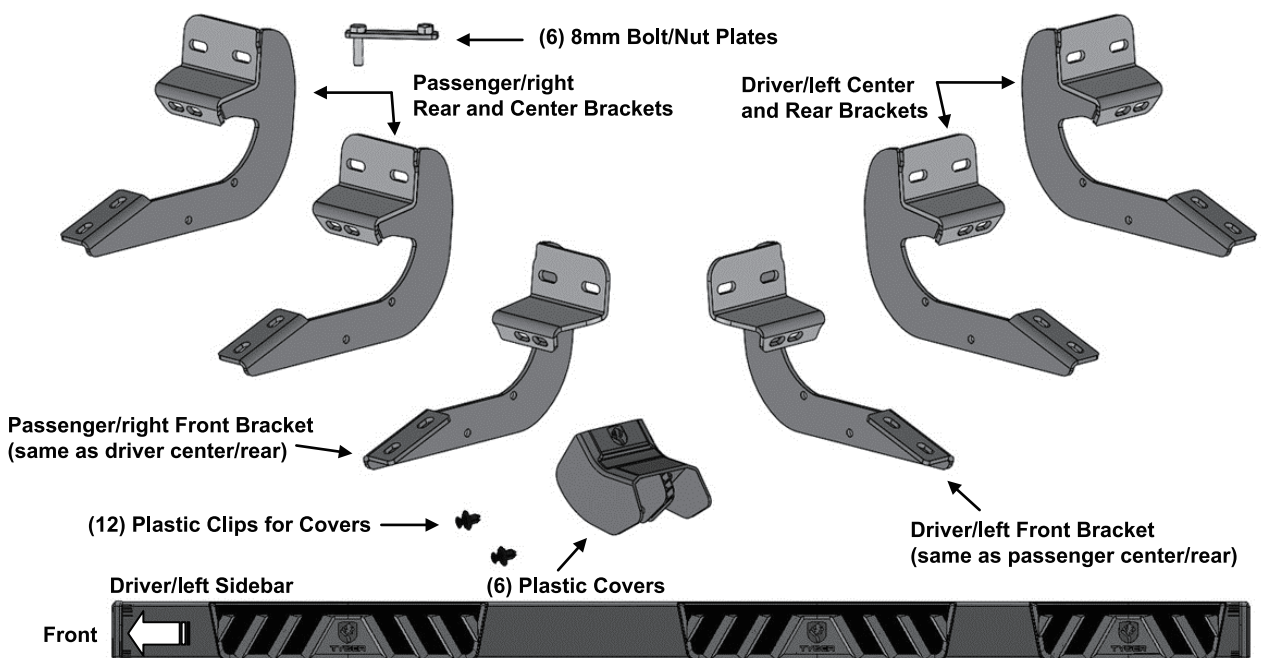



PROCEDURE

REMOVE CONTENTS FROM BOX. VERIFY ALL PARTS ARE PRESENT. READ INSTRUCTIONS CAREFULLY BEFORE STARTING INSTALLATION. DRILLING MAY BE REQUIRED.

STEP 1

Starting at the passenger side-front of the vehicle, remove the sealing tape covering the factory holes in the side of the inner panel, (Figure 1).



(Fig 1) 2009-mid 2015 Passenger front mounting location (No factory holes in pinch weld 2009-2012 models)

STEP 2

Determine the correct procedure to attach the driver side front Bracket for your model/year:

Models without factory threaded inserts in body panel:

a. Select (1) 8mm Bolt/nut Plate, (Figure 2). Partially thread an 8mm Hex Bolt onto the threaded end of the Nut Plate, (Figure 3). Thread the Hex Bolt in until it is flush with the welded nut. Use the Hex Bolt as a handle and insert the Bolt and Nut Plate into the oval hole, (Figure 4). Feed the threaded bolt on the Bolt Plate through one of the hex shaped factory holes.

b. Thread (1) 8mm Plastic Retainer onto the threaded end and down tight against the body panel, (Figure 5).

NOTE: The Plastic Retainer is designed to keep the Bolt/Nut Plate from falling into the body panel and to aid in Bracket installation.

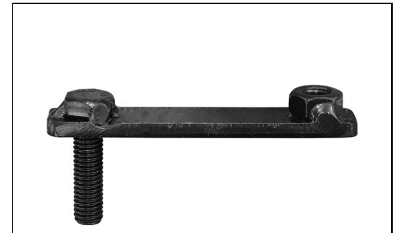

(Fig 2) 8mm Bolt-8mm Nut Plate, NOTE: 8mm Bolt-Nut Plate is not required on models with threaded inserts

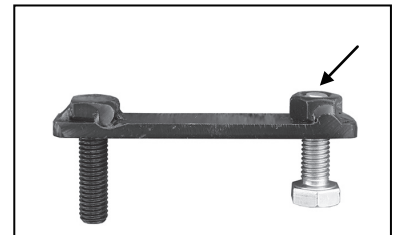

(Fig 3) Thread (1) 8mm Hex Bolt into the nut on the plate. Stop when bolt reaches end of nut as pictured

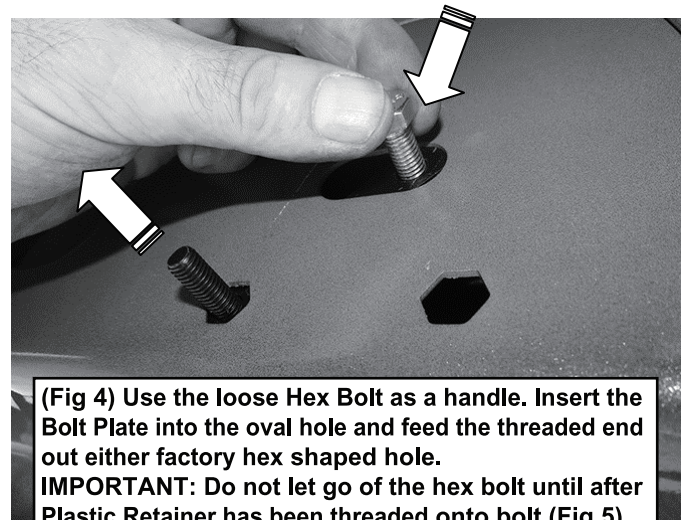

(Fig 4) Use the loose Hex Bolt as a handle. Insert the Bolt Plate into the oval hole and feed the threaded end out either factory hex shaped hole. **IMPORTANT:** Do not let go of the hex bolt until after Plastic Retainer has been threaded onto bolt (Fig 5)

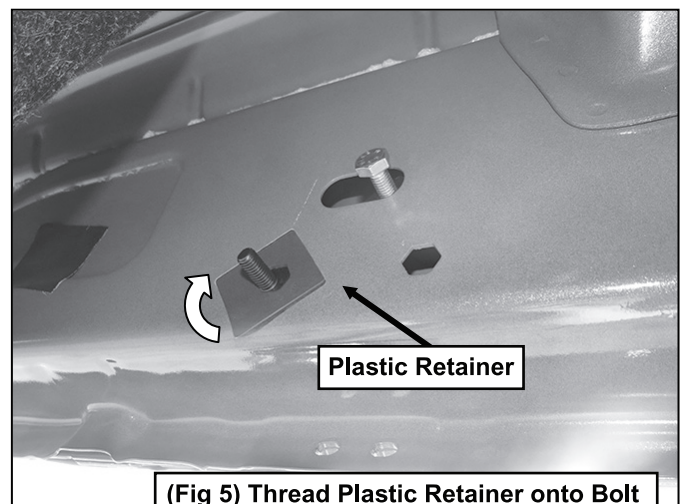

(Fig 5) Thread Plastic Retainer onto Bolt Plate to hold Bolt Plate in position.



c. Select the Passenger/right Front Bracket, (Figure 6). Attach the Bracket to the threaded end of the Bolt Plate with (1) 8mm Flat Washer, (1) 8mm Lock washer and (1) 8mm Hex Nut, (Figure 7).

IMPORTANT: Passenger/right Front Bracket is the same as the Driver/left Center and Rear Brackets. Do not tighten hardware at this time.

d. Remove the 8mm Hex Bolt from the nut on the Bolt Plate from Step 3a. Rotate the Bolt on the Bolt Plate until the threaded nut lines up with the remaining hole in the Mounting Bracket and body panel, (Figure 7). Attach the Bracket to the threaded Nut Plate with (1) 8mm x 30mm Hex Bolt, (1) 8mm Lock Washer and (1) 8mm Flat Washer, (Figure 7). Do not tighten hardware.

Models with factory threaded inserts:

a. Attach the Passenger/right Front Bracket to the threaded inserts with (2) 8mm x 30mm Hex Bolts, (2) 8mm Lock Washers and (2) 8mm Flat Washer, (Figures 8 & 9). Leave hardware loose at this time.

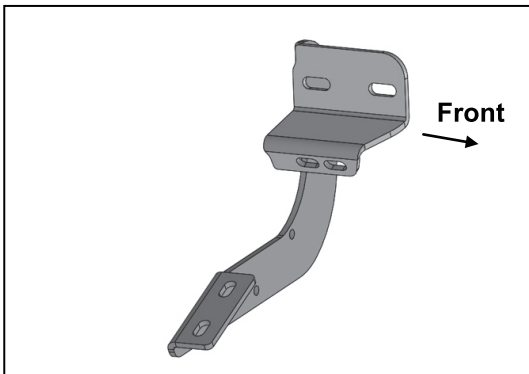

(Fig 6) Passenger side Front Bracket
(NOTE: Same Bracket is used on driver side center and rear locations)

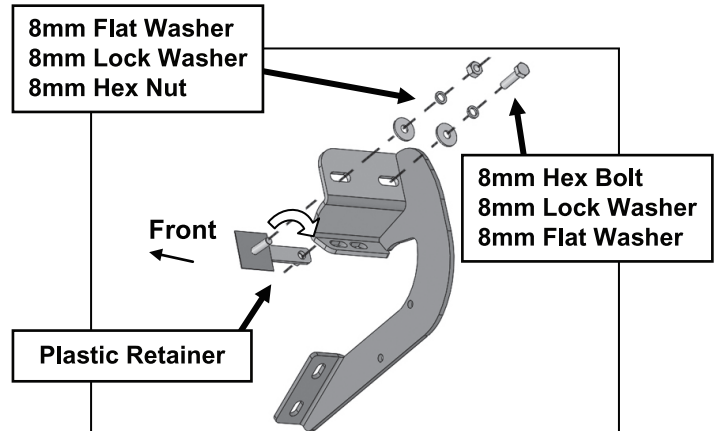

(Fig 7) Attach Bracket to threaded end of Bolt Plate first. Remove 8mm Hex Bolt (see Fig 3). Rotate Bolt Plate to line up with remaining factory hex shaped hole.

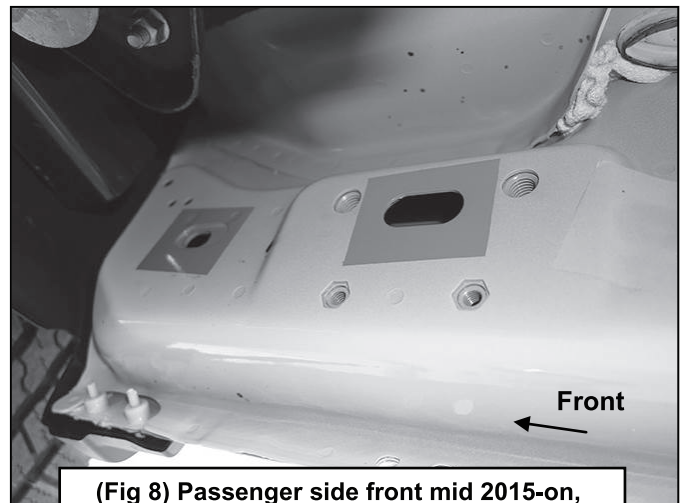

(Fig 8) Passenger side front mid 2015-on, models with factory installed threaded inserts

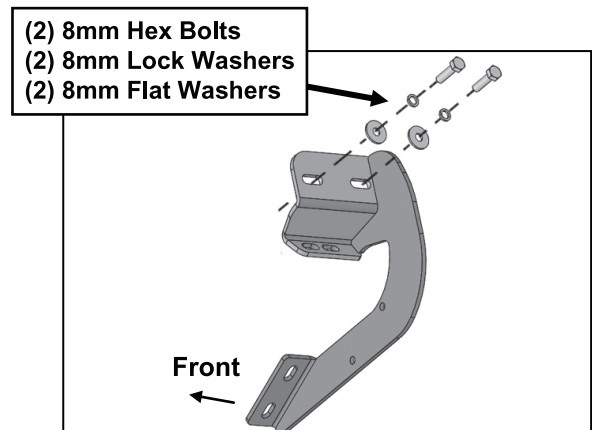

(Fig 9) Passenger/right Front Mounting Bracket illustrated for models with threaded inserts



STEP 3

Next, attach the Bracket to the back of the pinch weld with (2) 6mm x 25mm Button Head Bolts, (4) 6mm Flat Washers and (2) 6mm Flange Nuts, (Figures 10 & 11). Do not fully tighten hardware at this time.

IMPORTANT: 2009-12 models not equipped with factory holes will require drilling through the pinch weld to fully attach Bracket. Do not drill through pinch weld at this time, (see Step 8).

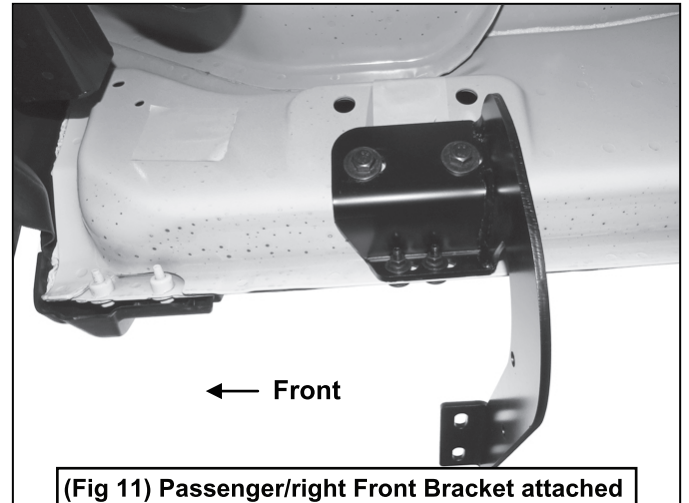
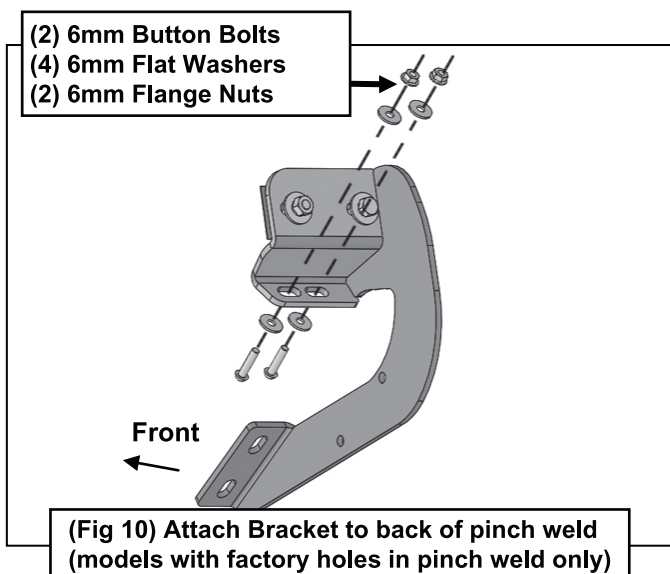

(Fig 11) Passenger/right Front Bracket attached to the body panel and pinch trim

IMPORTANT: 2009-2012 models without holes in pinch weld will require drilling 1/4" holes through pinch weld to attach bracket. Do complete installation of sidebars first, level sidebar before drilling holes for bracket.

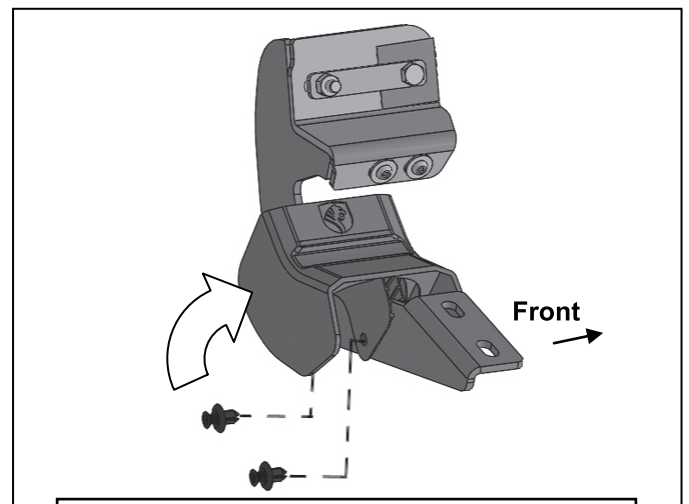

(Fig 12) Slide Cover over top of Bracket. Attach Cover to Bracket with (2) Retaining Clips

STEP 4

Select (1) Plastic Bracket Cover and (2) Retaining Clips. Slide the Cover over the passenger/right front Bracket. Line up the (2) mounting holes in the Cover with the holes in the Bracket. Insert the Clip into the holes and push center pin to expand Clip, (Figure 12). Repeat this Step for all Cover installations.



STEP 5

Move along the side of the body panel to the center mounting location, (Figure 13). Repeat the appropriate Steps 1—4 to install the Passenger/right Center Bracket, (Figures 14 & 15).

IMPORTANT: The front bracket is different from the center and rear Brackets, (see illustration above-note direction of mounting plate).

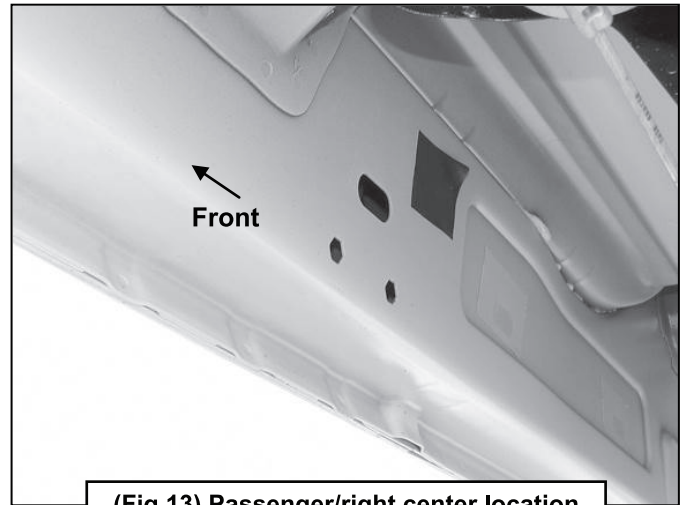

(Fig 13) Passenger/right center location

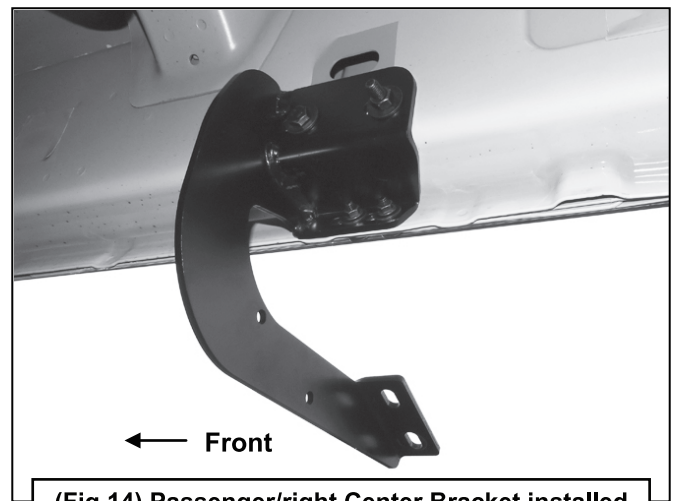

(Fig 14) Passenger/right Center Bracket installed

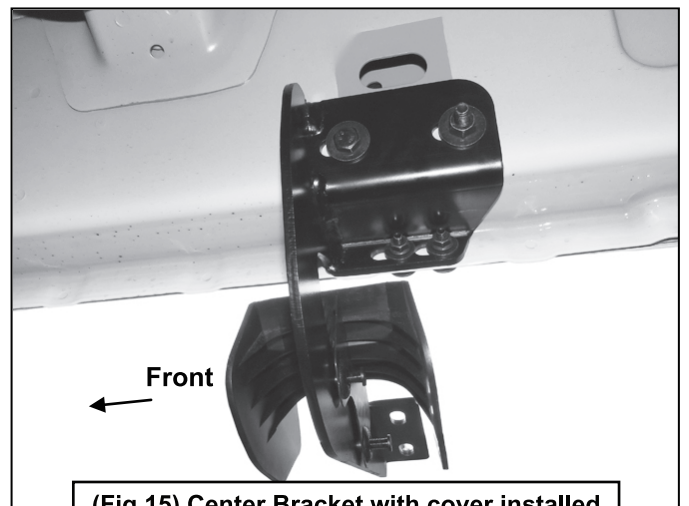

(Fig 15) Center Bracket with cover installed



STEP 6

Move to the rear location, (Figure 16). Repeat Step 5 to install the Rear Mounting Bracket, (Figures 17 & 18). Leave hardware loose.



(Fig 16) Passenger/right rear mounting location

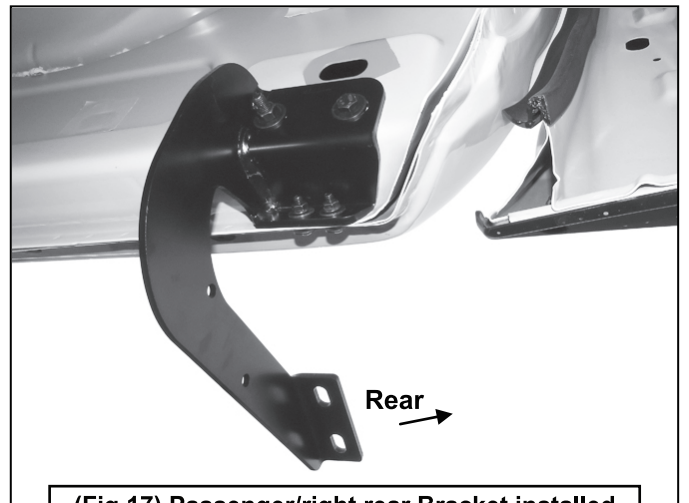

(Fig 17) Passenger/right rear Bracket installed

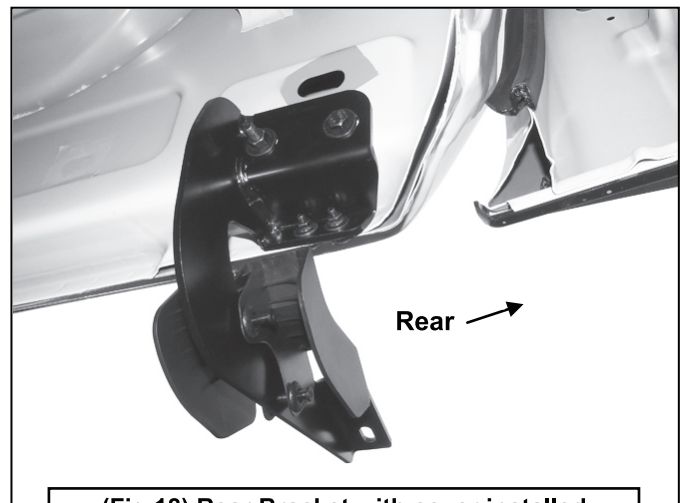

(Fig 18) Rear Bracket with cover installed



TYGER®

STEP 7

Select the Passenger/right Sidebar. Carefully position the Sidebar onto the (3) Mounting Brackets.

IMPORTANT: Do not slide, (front to back or rotate), the Sidebar on the Brackets or damage to the finish on the Sidebar may result. Attach the Sidebar to the (3) Brackets with (6) 8mm Combination Hex Bolts, (Figures 19—21). Do not fully tighten at this time.

STEP 8

Properly level and adjust the Sidebar and fully tighten all hardware.

2009-12 models requiring drilling through pinch trim:

- Level the Sidebar to the vehicle. Make sure all (3) Brackets are tight against the bottom of the body panel and tighten all mounting hardware.
- Mark the location of the slots onto the pinch weld.
- Drill (2) 1/4" holes through the pinch weld for each Bracket. **IMPORTANT:** Do not drill too close to the bottom edge of the pinch weld. Drill the holes in the center of the marked slots.
- Check for level then fully tighten all hardware.

STEP 9

Repeat Steps 1—8 for driver/left Sidebar installation.

NOTE: Refer to the illustration on Page 1 to identify the correct Mounting Brackets for each of the remaining locations.

STEP 10

Do periodic inspections to the installation to make sure that all hardware is secure and tight.

To protect your investment, wax this product after installing. Regular waxing is recommended to add a protective layer over the finish. Do not use any type of polish or wax that may contain abrasives that could damage the finish. Mild soap may be used to clean the Sidebars.

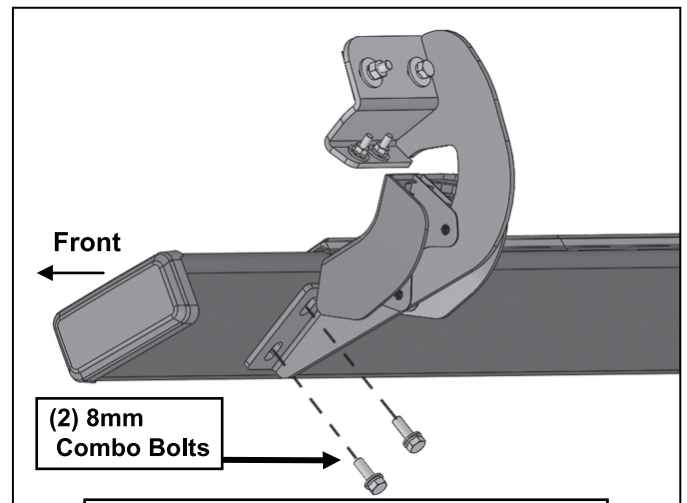

(Fig 19) Passenger/right Sidebar attached to Front Bracket illustrated

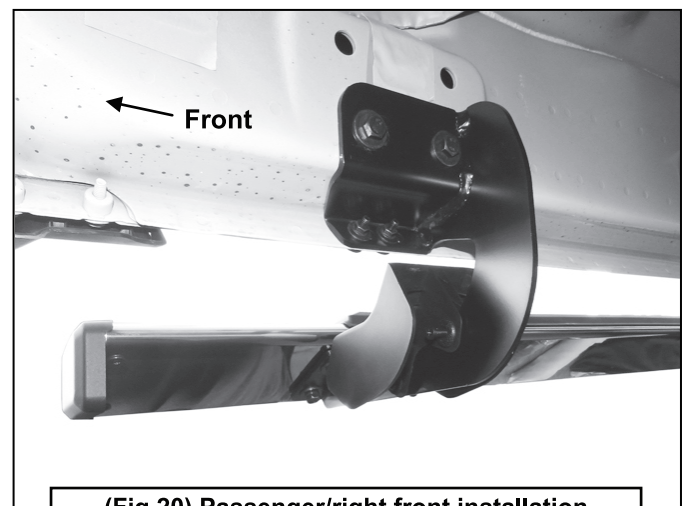

(Fig 20) Passenger/right front installation

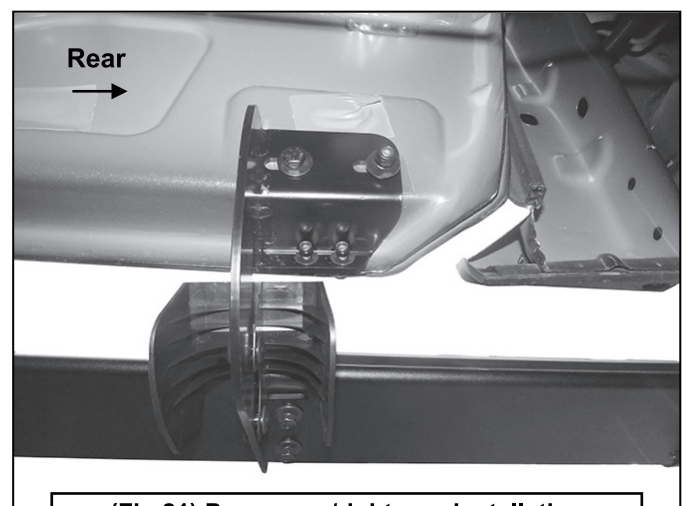

(Fig 21) Passenger/right rear installation