



## RISER®

TG-RS5C50037  
TG-RS5C50038

### BEFORE INSTALLATION

READ INSTRUCTIONS CAREFULLY BEFORE STARTING INSTALLATION. REMOVE CONTENTS FROM BOX AND VERIFY ALL PARTS ARE PRESENT. FAILURE TO IDENTIFY DAMAGE BEFORE INSTALLATION COULD LEAD TO A REJECTION OF ANY CLAIM. IF MISSING PARTS OR ANY DAMAGE FOUND, PLEASE TAKE A PICTURE FOR THE CLAIM PURPOSE.

### TORQUE VALUE

Fastener Size	Class 8.8 Torque (ft-lbs)	Class 10.9 Torque (ft-lbs)
6mm	6-7	6-7
8mm	15-16	22-23
10mm	31-32	44-45
12mm	54-55	78-79
14mm	87-88	125-126

### PARTS LIST

- x1** Driver/left side T5 Sidebar
- x1** Passenger/right side T5 Sidebar
- x1** Passenger/right Front Upper Bracket (all incl. DEF)
- x1** Passenger/right Front Lower Bracket (all incl. DEF)
- x1** Driver/left side 3rd Mounting Bracket
- x6** Mounting Brackets (use for left or right)
- x8** Plastic Bracket Covers
- x16** Plastic Retaining Clips
- x15** 8-1.25mm Clip-On Nuts
- x1** 8-1.25mm Bolt Plate
- x17** 8-1.25mm x 25mm Hex Bolts
- x17** 8mm x 24mm x 2mm Flat Washers
- x17** 8mm Lock Washers
- x1** 8mm Nylon Lock Nut
- x16** 8-1.25mm x 25mm Combo Hex Bolts

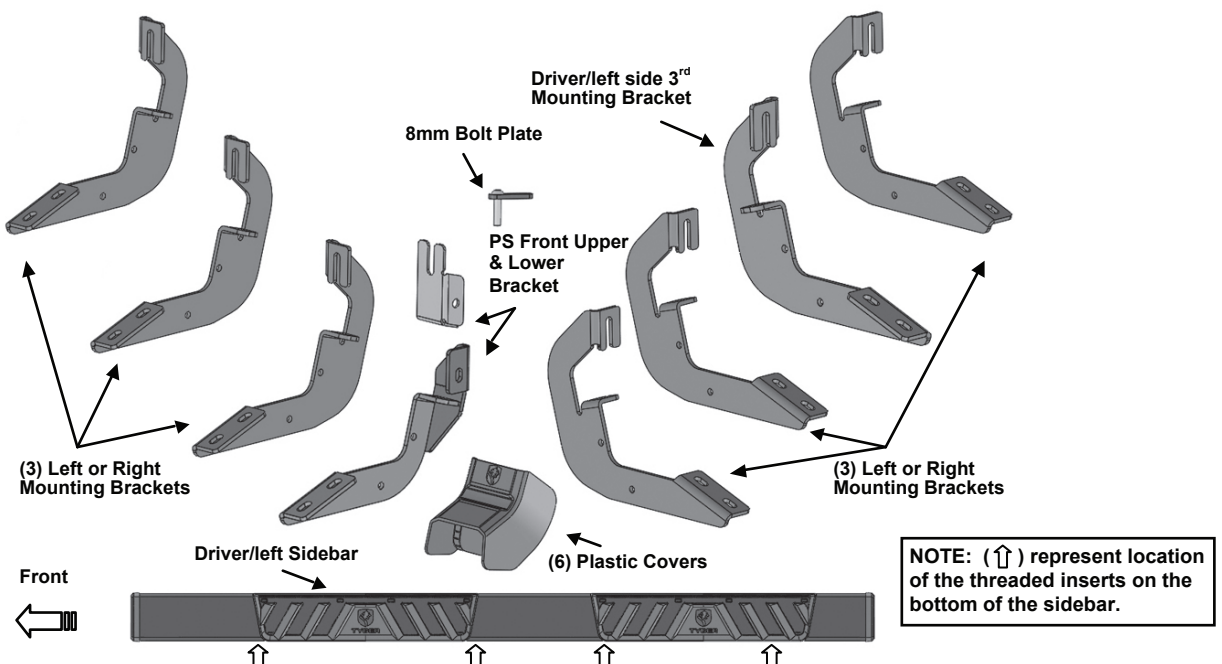



## NOTE

On models with def tank, select a flat, level area for installation. May require cutting.

## STEP 1

Start the installation under the driver side of the vehicle. Locate the 4 tabs along the bottom edge of the body, (pinch weld). Mounting Brackets will bolt to all mounting tabs, (Fig 1). Directly above each tab is a top mounting location on the side of the body panel. Hold a Bracket up in place to help determine the mounting holes to use along the body.

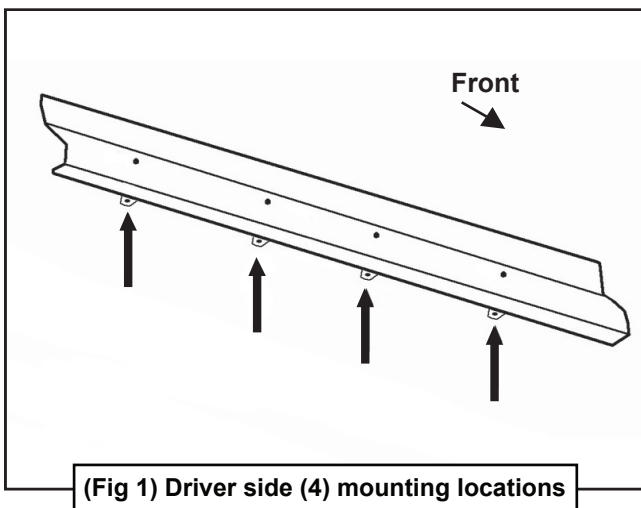

## STEP 2

Determine the correct procedure for your model year and each Bracket location.

### **Bottom mounting location on the edge of the pinch weld.**

#### *Flat tab on pinch weld with factory installed weld nut:*

Thread hex bolt into weld nut from the backside-down to clear paint from threads, (Fig 2).

#### *Flat tab on pinch weld with hole:*

Select (1) 8mm Clip Nut. Slide the Clip Nut over the tab with the nut facing up behind the tab, (Figs 3-6). Line up threaded nut with hole in the tab. Repeat for each mounting location.

### **Locate top mounting location on the back side of the body panel.**

#### *Models with factory installed threaded insert in body panel:*

Thread 8mm Hex Bolt into threaded insert to clear paint as required, (Figs 2-3).

#### *Large and small hole in side of body panel:*

Remove the rubber plug from the larger hole, (Figs 4-5). Select (1) 8mm Clip Nut. Slide the Clip Nut into the larger hole. Line up the threaded nut with the smaller hole, (Fig 6).

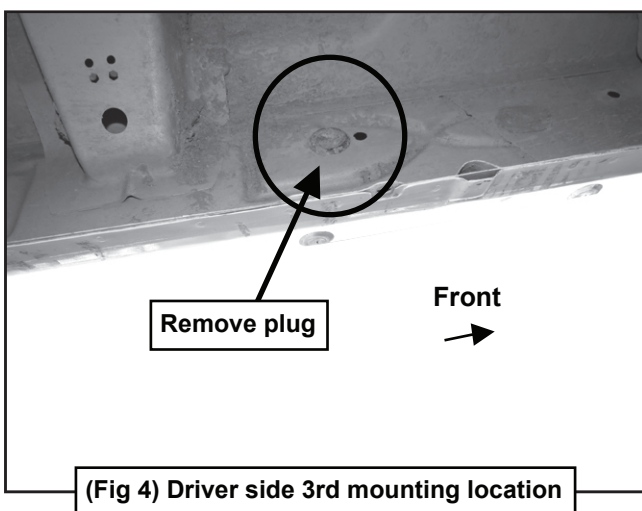
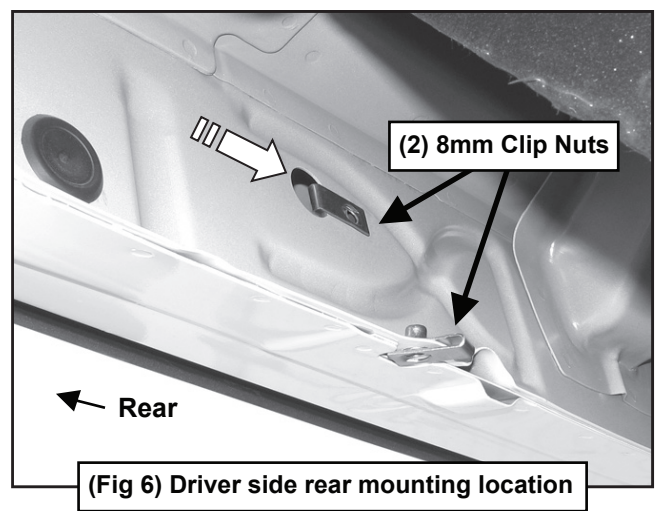
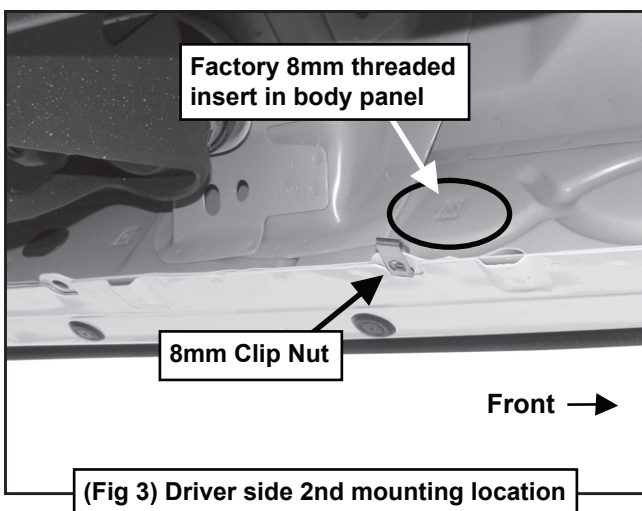
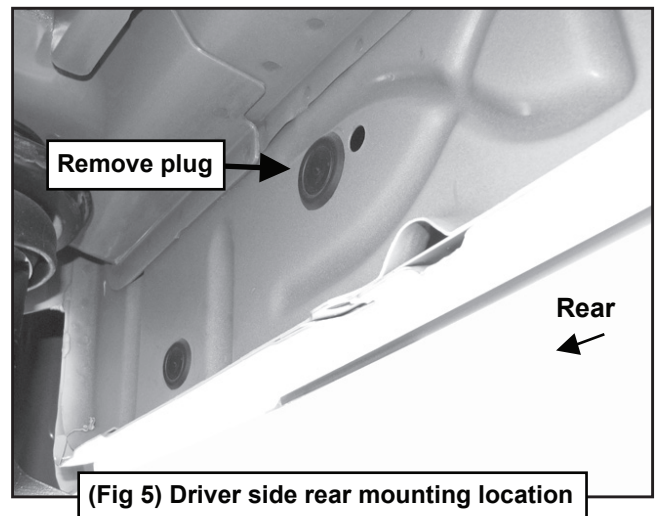
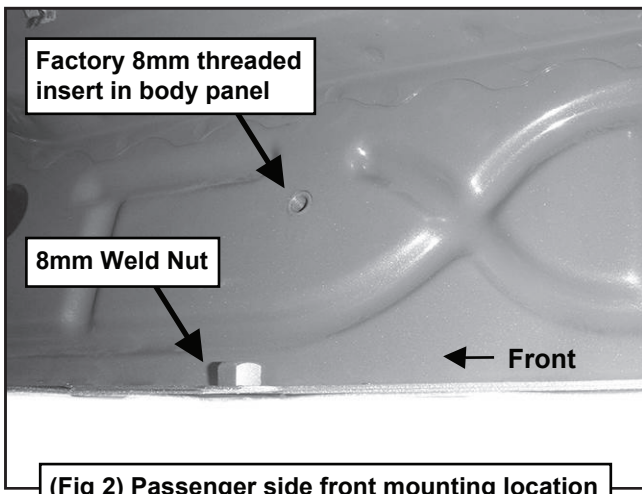



## STEP 3

Select (1) Mounting Bracket.

**NOTE:** (6) Brackets are universal and will fit all left or right side except for the driver/left side 3rd mounting location. See illustration above to help determine correct Bracket. Bolt the Mounting Bracket to the Clip Nuts and/or the factory threaded holes with (2) 8mm Hex Bolts, (2) 8mm Lock Washers and (2) 8mm Flat Washers, (Fig 7). Do not tighten hardware.

## STEP 4

Select (1) Plastic Bracket Cover and (2) Retaining Clips. Slide the Cover over the passenger/right front Bracket. Line up the (2) mounting holes in the Cover with the holes in the Bracket. Insert the Clip into the holes and push center pin to expand Clip, (Figs 8-9). Repeat Step for all Cover installations. Notes please install all plastic covers onto the brackets before installing the side bar.

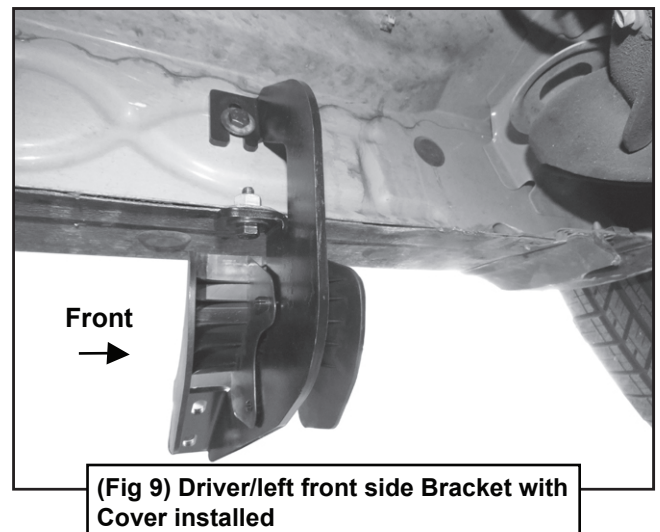
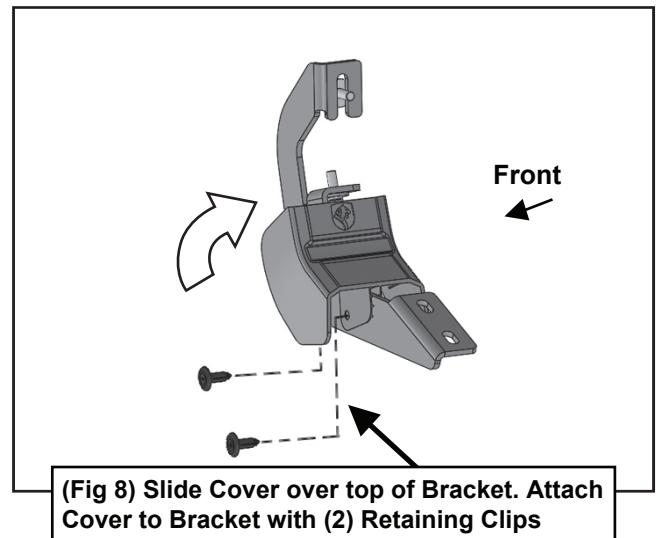
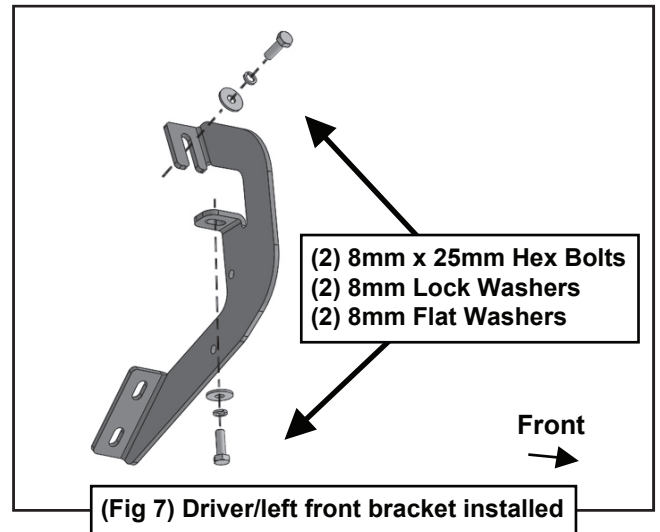



## STEP 5

Move to the 2nd mounting location along the body panel and repeat Steps 2-4 to install a universal Bracket, (Fig 10).

## STEP 6

Continue to move to the 3rd mounting location. Select the Driver/left side 3rd Mounting Bracket, (Fig 11).

**NOTE:** When installed properly the mounting tabs on the Mounting Bracket will face towards the front. Repeat Steps 2-4 to install the Bracket in the 3rd mounting location.

## STEP 7

Move the last, rear, mounting location along the body panel and repeat Steps 2-4 to install a universal Bracket, (Fig 12).

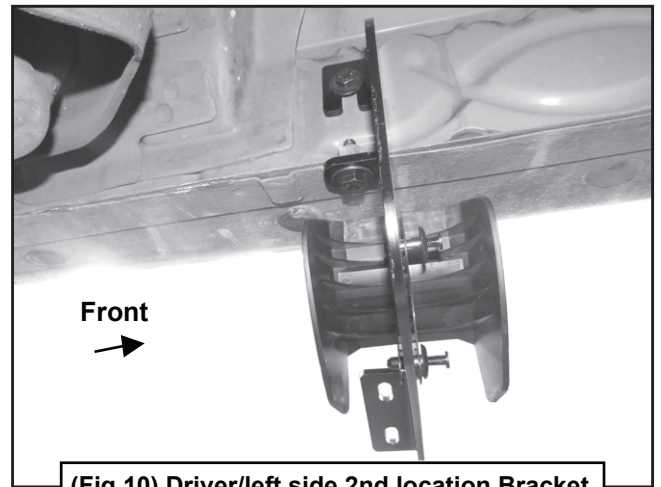

(Fig 10) Driver/left side 2nd location Bracket with cover installed

**NOTE:** The mounting tabs on the DS 3rd Bracket face towards the front.

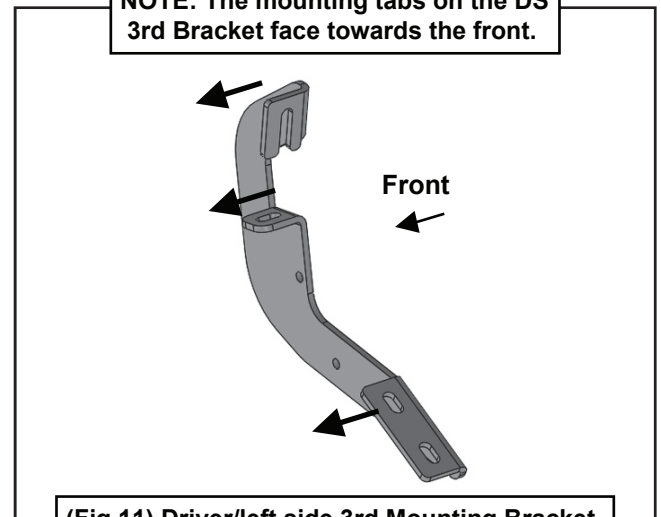

(Fig 11) Driver/left side 3rd Mounting Bracket

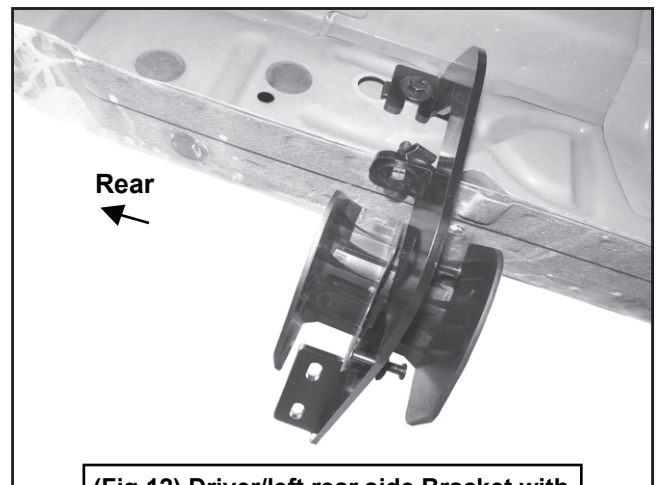

(Fig 12) Driver/left rear side Bracket with cover installed



## STEP 8

Select the Driver/left Sidebar. Carefully position the Sidebar onto the (4) Mounting Brackets.

**IMPORTANT:** Do not slide, (front to back or rotate), the Sidebar on the Brackets or damage to the finish on the Sidebar may result. Attach the Sidebar to the (4) Brackets with (8) 8mm Combination Hex Bolts, (Figs 13-15). Do not fully tighten at this time.

## STEP 9

Level and adjust the Sidebar and fully tighten all hardware.

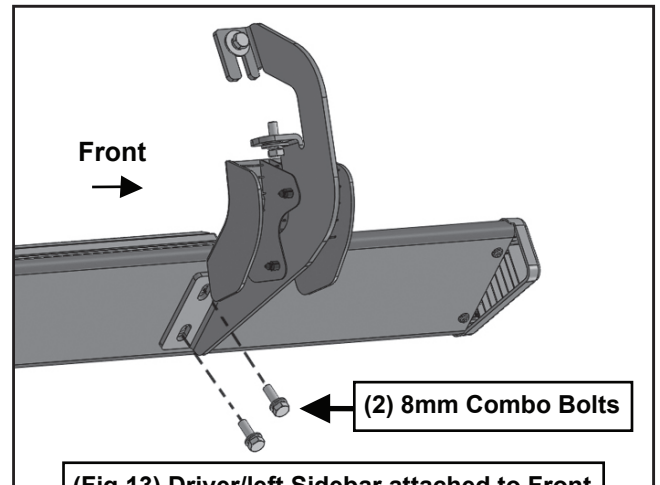

(Fig 13) Driver/left Sidebar attached to Front Bracket illustrated

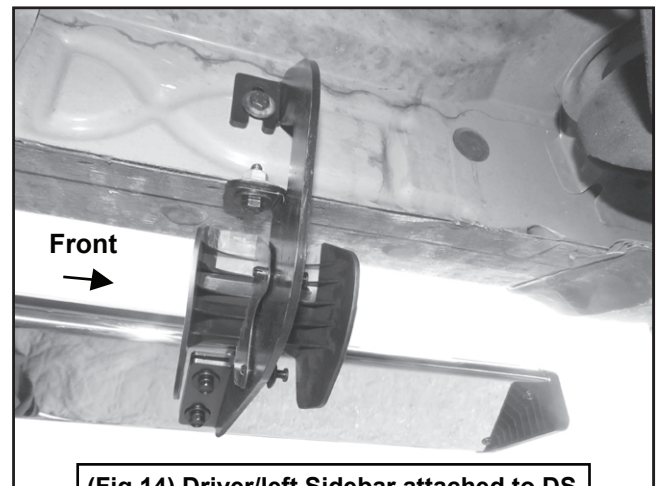

(Fig 14) Driver/left Sidebar attached to DS Front Bracket

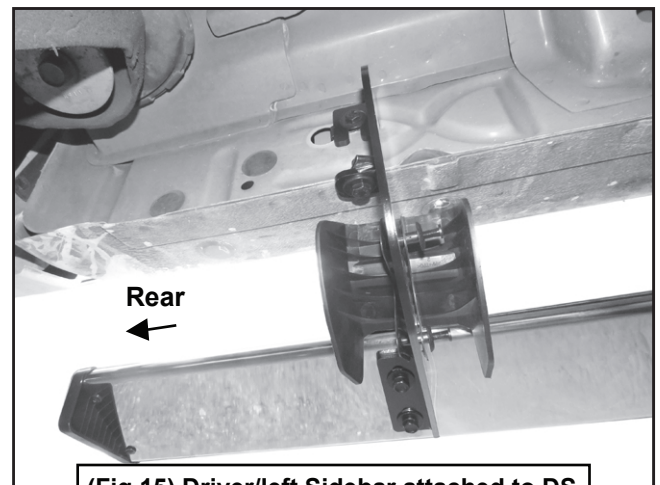

(Fig 15) Driver/left Sidebar attached to DS Rear Bracket



## STEP 10

Move to the passenger side of the vehicle. On the passenger side, determine if the vehicle is equipped with a plastic diesel exhaust fluid (DEF) tank, (Figs 17-18).

*Models without DEF tank, skip to Step 9.*

**Models with DEF tank:**

The tank sits close to the side of the body. With specialized tools, the passenger front upper and lower Bracket can be installed but room is very limited. Determine model year of vehicle before proceeding.

**Up to 2016 models:**

It may be easier to drop the tank down to access the inner side of the body panel for upper bracket installation. Tank will not need to be removed, only dropped down for access to mounting location.

**IMPORTANT:** If tank is full, it will be very heavy and assistance is highly recommended to avoid injury or damage to the vehicle or the tank. It is recommended that installation is performed when the DEF tank is low on fluid before dropping the tank.

**a.** On models with plastic lower tray under the tank, remove the (3) hex bolts attaching the tray to the frame, (Fig 16), and remove the tray.

**b.** Release the tank filler hose. Release the plug for the sending unit on the top of the tank.

**c.** Support the tank with a floor jack. Place a smooth flat surface, (wooden block for example), between the floor jack and the tank to avoid damaging the plastic tank. Do not push up on the tank; only support the weight of the tank with the jack.

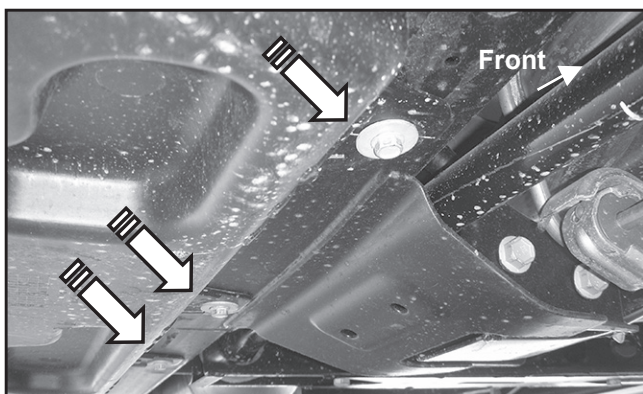

(Fig 16) 07-19 Passenger side front pictured with DEF tank cover. Remove (3) hex bolts to remove cover

**d.** Remove the (2) bolts securing the tank straps to the vehicle, (Fig 17). Tilt the straps to release from the brackets. Slowly lower the tank until the top of the tank is almost visible. Use blocks or stands to support the tank while installing the front Upper and Lower Brackets.

**e.** Proceed to Step 9.

**On 2017 models and on:**

**a.** Remove the (4) hex bolts attaching plastic cover to DEF tank, (Fig 18A) and remove plastic cover, (Fig 18B).

**NOTE:** On 2017-on 2500/3500 models, only remove plastic cover from DEF tank. Do not lower DEF tank and proceed to Step 11.

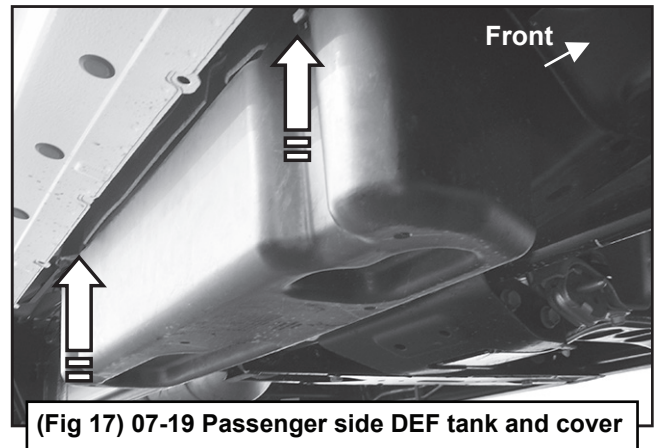

(Fig 17) 07-19 Passenger side DEF tank and cover

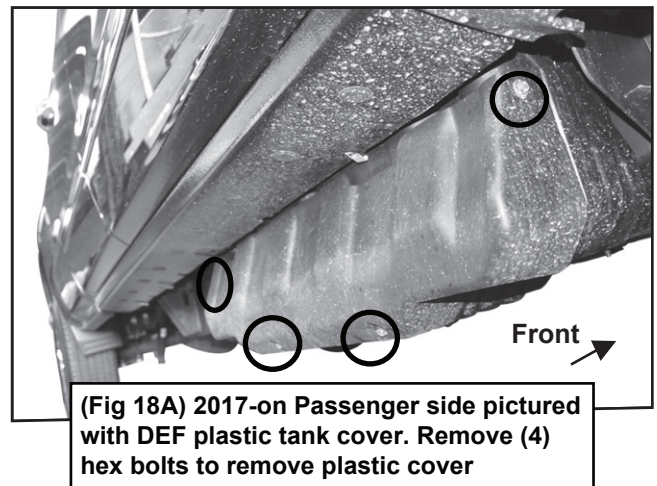

(Fig 18A) 2017-on Passenger side pictured with DEF plastic tank cover. Remove (4) hex bolts to remove plastic cover

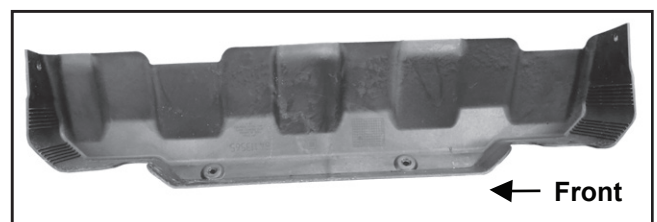

(Fig 18B) 2017-on Passenger side DEF cover removed



## STEP 11

Locate the first tab on the edge of the pinch weld, (Figs 2-5, 20 & 22). Select the Upper Bracket, (Fig 19). Repeat Steps 2-3 to attach the passenger front Upper Bracket to the side of the body panel, (Fig 20). Do not tighten hardware at this time.

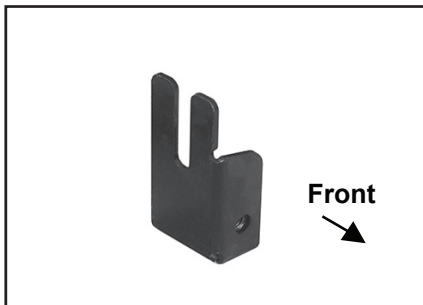

(Fig 19) Passenger/right Front Upper Bracket (all models)

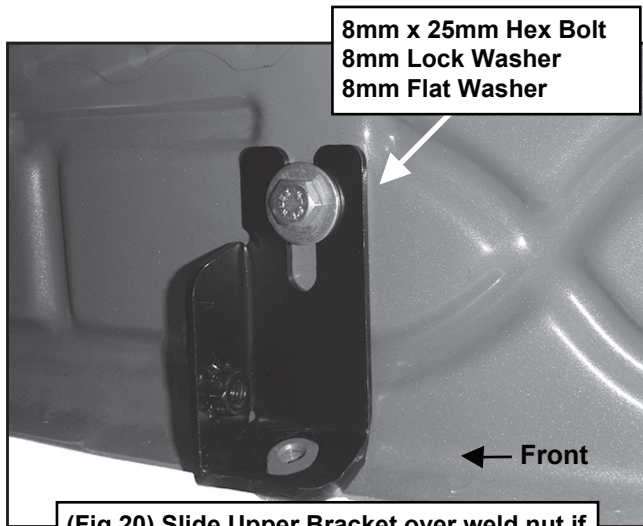

(Fig 20) Slide Upper Bracket over weld nut if equipped-also see Fig 2

## STEP 12

Line up the hole in the bottom of the Upper Bracket with the hole in the tab on the pinch weld.

### Models with a weld-nut:

Slide the Bracket over the weld-nut, (Fig 20). Attach the Lower Bracket to the bottom of the body and weld-nut with (1) 8mm x 25mm Hex Bolt, (1) 8mm Lock Washer and (1) 8mm Flat Washer, (Figs 23 & 27). Leave loose at this time.

### Models with flat tab and hole:

Insert the 8mm Bolt Plate down through the hole in the Upper Bracket and mounting tab, (Figs 21-22). Attach the Lower Bracket to the bottom of the body and Bolt Plate with (1) 8mm Flat Washer and (1) 8mm Nylon Lock Nut, (Figs 22 & 27). Leave loose at this time.



(Fig 21) 8mm x 35mm Bolt Plate

On models with flat tab (see Fig 3 & 4), insert 8mm Bolt Plate (Fig 16) down through Upper Bracket and mounting tab

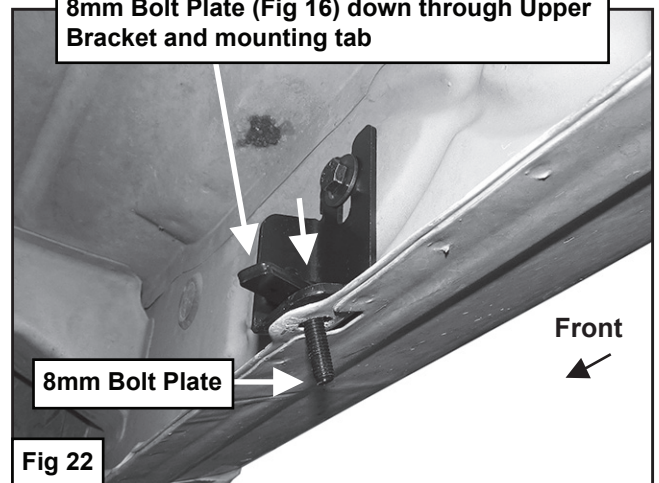

Fig 22





## STEP 13

Line up the side tab on the Lower Bracket with the threaded hole in the side of the Upper Bracket. Attach the Lower Bracket to the Upper Bracket with (1) 8mm x 25mm Hex Bolt, (1) 8mm Lock Washer and (1) 8mm Flat Washer, (Fig 28). Leave loose at this time.

## STEP 14

Repeat Steps 1-4 for the (3) remaining passenger side Bracket installations.

**NOTE:** Cradles on Brackets installed on passenger side will face forward.

### **2017-on 2500/3500 DEF tank models:**

Locate the 2nd tab bracket location along the bottom edge of the body, (pinch weld), (Fig 24). Hold the DEF cover in place and mark the location onto the cover, (Fig 25). Use a sharp knife or hacksaw blade to carefully cut a slot in the plastic cover to clear the 2nd Bracket, (Fig 26). Remove as little plastic as possible.

## STEP 15

Repeat Steps 6-7 to install the passenger/right Sidebar.

## STEP 16

Once the Sidebar has been installed and all hardware fully tightened, reinstall the DEF tank and cover, if equipped, as described in Steps 8 & 12.

## STEP 17

Do periodic inspections to the installation to make sure that all hardware is secure and tight.

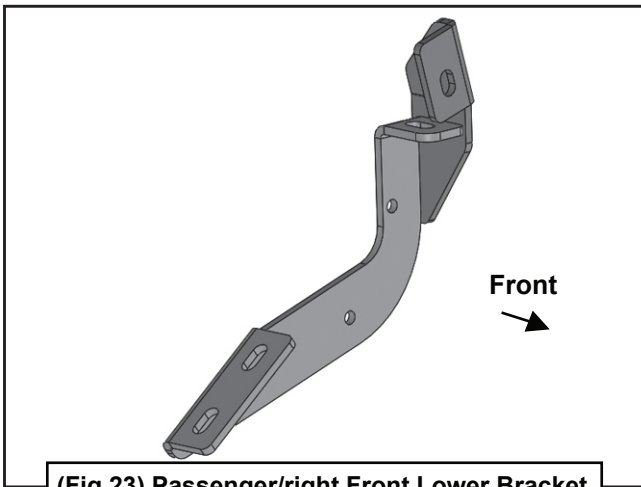

(Fig 23) Passenger/right Front Lower Bracket (all models)

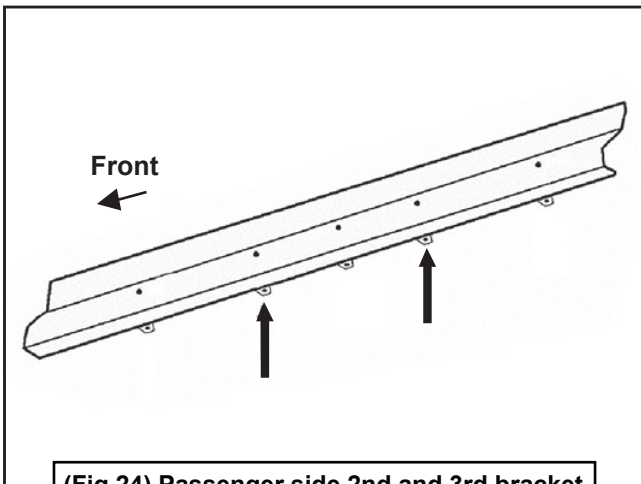

(Fig 24) Passenger side 2nd and 3rd bracket location from back of body panel

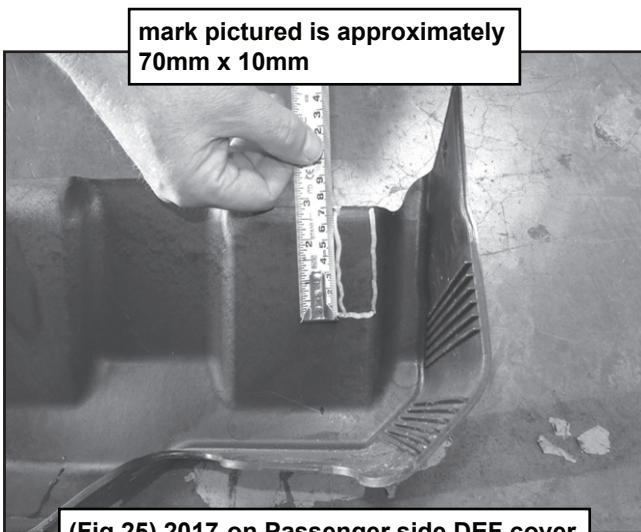

(Fig 25) 2017-on Passenger side DEF cover marked for trimming

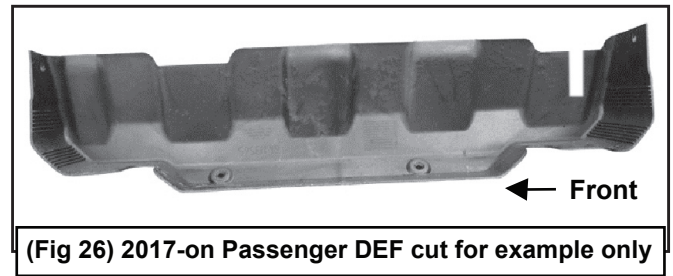

(Fig 26) 2017-on Passenger DEF cut for example only

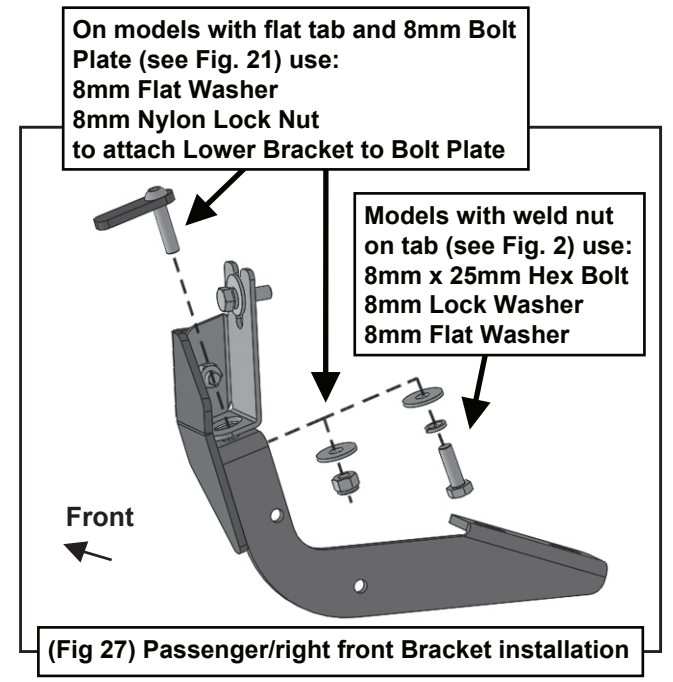

(Fig 27) Passenger/right front Bracket installation

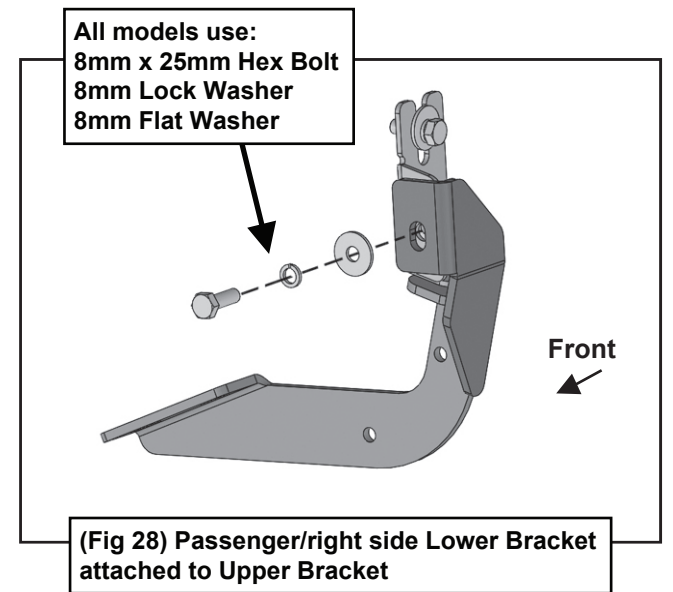

(Fig 28) Passenger/right side Lower Bracket attached to Upper Bracket