



## RISER®

TG-RS2D41078

### BEFORE INSTALLATION

READ INSTRUCTIONS CAREFULLY BEFORE STARTING INSTALLATION. REMOVE CONTENTS FROM BOX AND VERIFY ALL PARTS ARE PRESENT. FAILURE TO IDENTIFY DAMAGE BEFORE INSTALLATION COULD LEAD TO A REJECTION OF ANY CLAIM. IF MISSING PARTS OR ANY DAMAGE FOUND, PLEASE TAKE A PICTURE FOR THE CLAIM PURPOSE.

### TORQUE VALUES

Fastener Size	Class 8.8 Torque (ft-lbs)	Class 10.9 Torque (ft-lbs)
6mm	6-7	6-7
8mm	15-16	22-23
10mm	31-32	44-45
12mm	54-55	78-79
14mm	87-88	125-126

### Parts List

- x1 Driver/Left Side Step
- x1 Passenger/Right Side Step
- x2 Driver/left Front Brackets (also fits passenger/right rear location)
- x2 Passenger/right Front Brackets (also fits driver/left rear location)
- x4 Plastic Bracket Covers
- x8 Plastic Clips for Covers
- x4 8mm Nut/Bolt Plates
- x4 8mm Plastic Retainers
- x8 8-1.25mm x 25mm Combo Hex Bolts
- x8 8-1.25mm x 30 Hex Bolts
- x8 8mm x 24mm x 2mm Flat Washers
- x8 8mm Lock Washers
- x4 8mm Hex Nuts
- x8 6-1.0mm x 25mm Button Head Bolts
- x16 6mm x 18mm x 1.6mm Flat Washers
- x8 6mm Flange Nuts
- x1 4mm Wrench

### \*Bracket Types

<b>A</b>	Passenger/Right Rear Bracket Driver/Left Front Bracket
<b>B</b>	Driver/Left Rear Bracket Passenger/Right Front Bracket

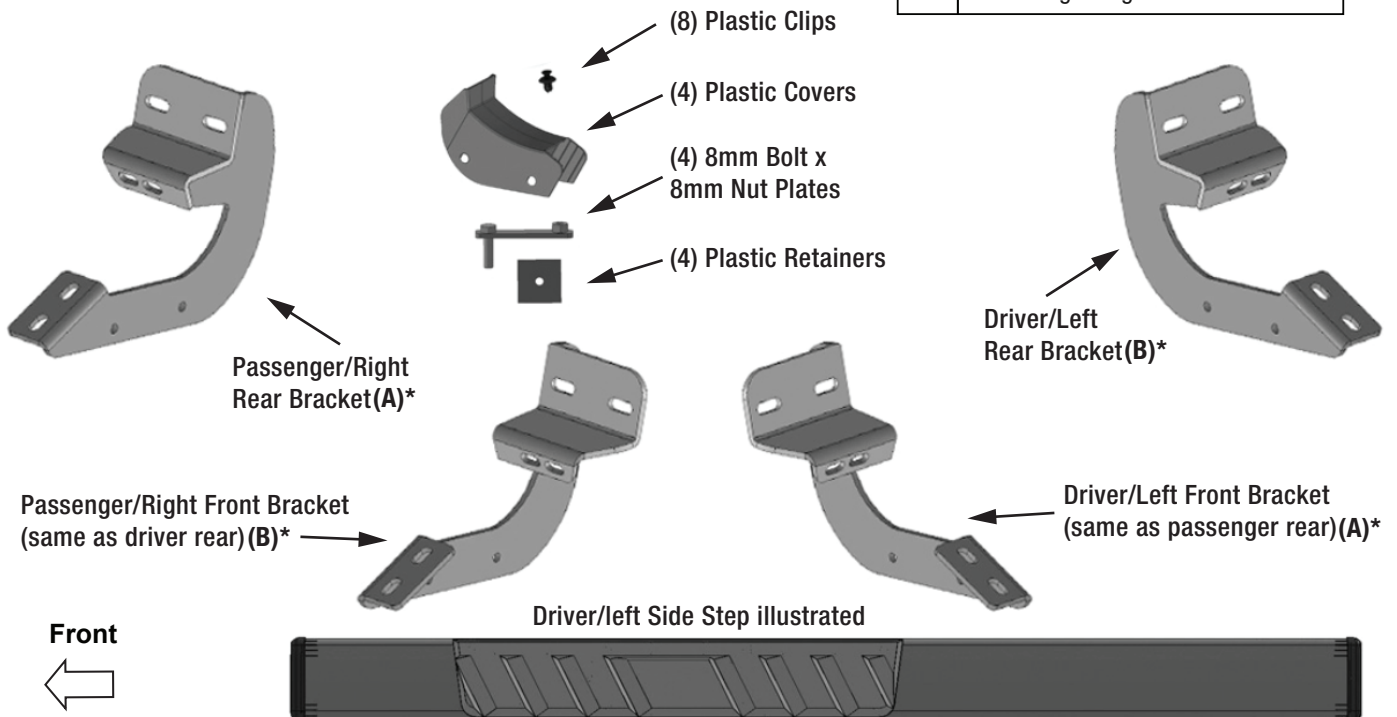



## STEP 1

REMOVE CONTENTS FROM BOX. VERIFY ALL PARTS ARE PRESENT. READ INSTRUCTIONS CAREFULLY BEFORE STARTING INSTALLATION. DRILLING MAY BE REQUIRED.

## STEP 2

Starting at the driver side-front of the vehicle, remove the sealing tape covering the factory holes in the side of the inner panel, (Figure 1).

Driver/Left Side Installation Pictured

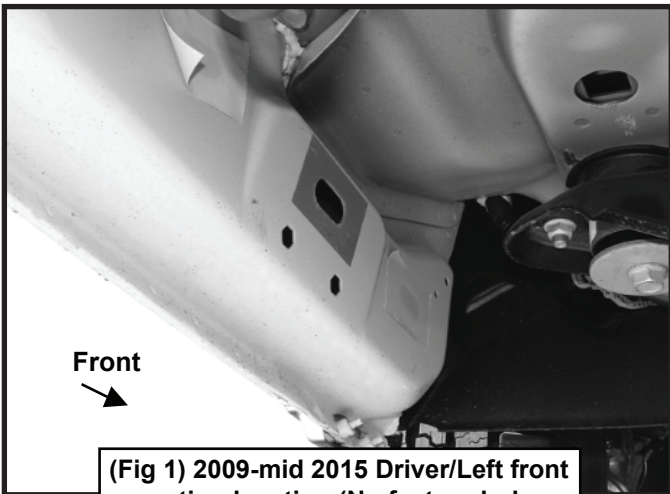

(Fig 1) 2009-mid 2015 Driver/Left front mounting location (No factory holes in pinch weld 2009-2011 models)

## STEP 3

Determine the correct procedure to attach the driver side front Bracket for your model/year:

### Models without factory threaded inserts in body panel:

a. Select (1) 8mm Bolt/nut Plate, (Figure 2). Partially thread an 8mm Hex Bolt onto the threaded end of the Nut Plate, (Figure 3). Thread the Hex Bolt in until it is flush with the welded nut. Use the Hex Bolt as a handle and insert the Bolt and Nut Plate into the oval hole, (Figure 4). Feed the threaded bolt on the Bolt Plate through one of the hex shaped factory holes.

Driver/Left Side Installation Pictured

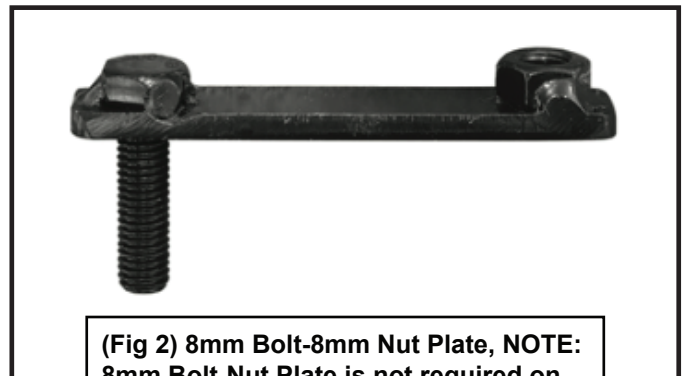

(Fig 2) 8mm Bolt-8mm Nut Plate, NOTE: 8mm Bolt-Nut Plate is not required on models with threaded inserts

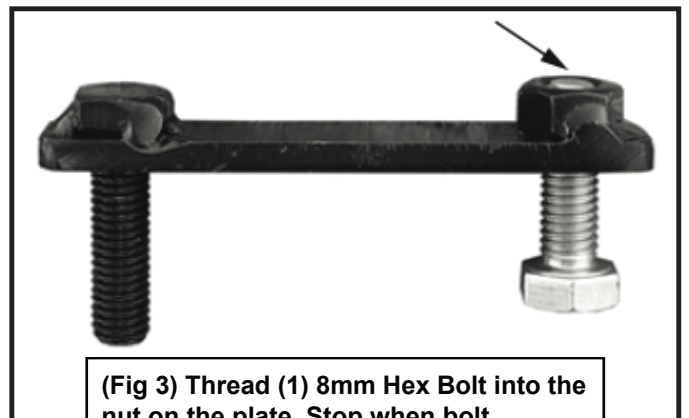

(Fig 3) Thread (1) 8mm Hex Bolt into the nut on the plate. Stop when bolt reaches end of nut as pictured



## Driver/Left Side Installation Pictured

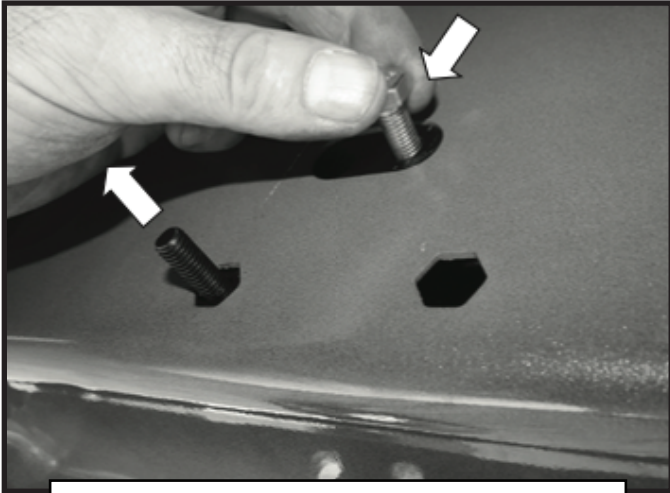

(Fig 4) Use the loose Hex Bolt as a handle. Insert the Bolt Plate into the oval hole and feed the threaded end out either factory hex shaped hole. **IMPORTANT:** Do not let go of the hex bolt until after Plastic Retainer has been threaded onto bolt (Fig 5)

b. Thread (1) 8mm Plastic Retainer onto the threaded end and down tight against the body panel, (Figure 5).

**NOTE:** The Plastic Retainer is designed to keep the Bolt/Nut Plate from falling into the body panel and to aid in Bracket installation.

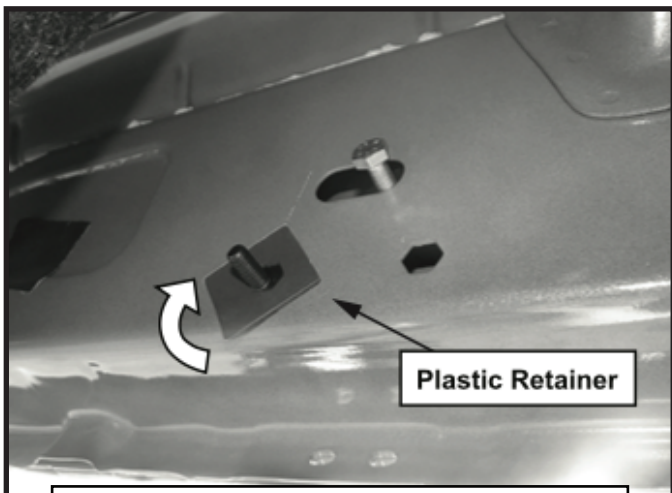

(Fig 5) Thread Plastic Retainer onto Bolt Plate to hold Bolt Plate in position.

c. Select the driver side front Mounting Bracket, (Figure 6). Attach the Bracket to the threaded end of the Bolt Plate with (1) 8mm Flat Washer, (1) 8mm Lock Washer and (1) 8mm Hex Nut, (Figure 7).

**IMPORTANT:** Driver/left front Bracket is the same as the passenger/right rear Bracket. DO NOT tighten hardware at this time.

## Driver/Left Side Installation Pictured

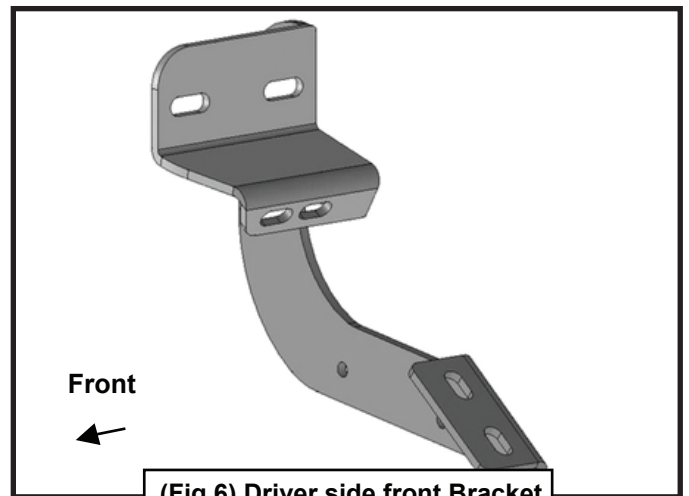

(Fig 6) Driver side front Bracket (note same Bracket is used on passenger side rear location)

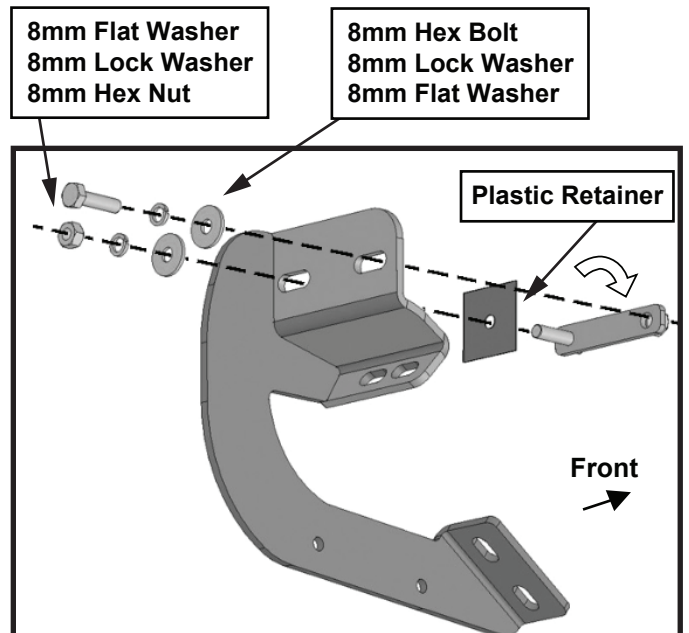

(Fig 7) Attach Bracket to threaded end of Bolt Plate first. Remove 8mm Hex Bolt (see Fig 3). Rotate Bolt Plate to line up with remaining factory hex shaped hole.



d. Remove the 8mm Hex Bolt from the nut on the Bolt Plate from **STEP 3a**. Rotate the Bolt on the Bolt Plate until the threaded nut lines up with the remaining hole in the Mounting Bracket and body panel, (Figure 7). Attach the Bracket to the threaded Nut Plate with (1) 8mm x 30mm Hex Bolt, (1) 8mm Lock Washer and (1) 8mm Flat Washer, (Figure 7). **DO NOT** tighten hardware.

### Models with factory threaded inserts:

a. Attach the driver side Front Bracket to the threaded inserts with (2) 8mm x 30mm Hex Bolts, (2) 8mm Lock Washers and (2) 8mm Flat Washer, (Figures 8 & 9). Leave hardware loose.

#### Driver/Left Side Installation Pictured

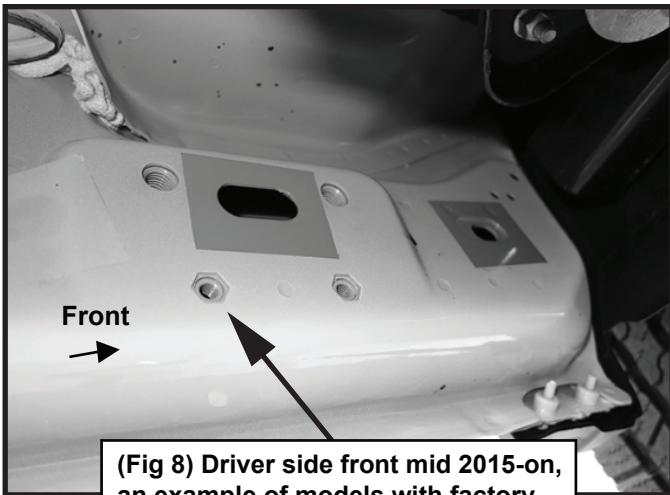

(Fig 8) Driver side front mid 2015-on, an example of models with factory installed threaded inserts

(2) 8mm Hex Bolts  
(2) 8mm Lock Washers  
(2) 8mm Flat Washers

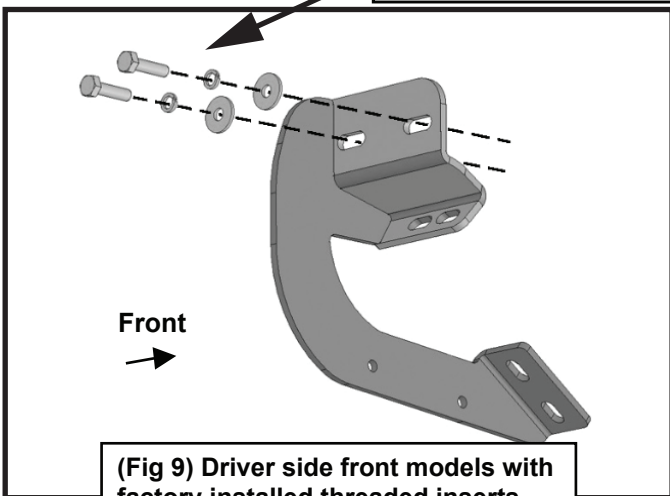

(Fig 9) Driver side front models with factory installed threaded inserts. Bolt Plate not required

## STEP 4

Next, attach the bottom of the Bracket to the back of the pinch weld with (2) 6mm x 25mm Button Head Screws, (4) 6mm Flat Washers and (2) 6mm Flange Nuts, (Figures 10 & 11). **DO NOT** fully tighten hardware at this time.

**IMPORTANT:** 2009-12 models may not be equipped with factory holes and will require drilling through the pinch weld to attach the bottom of the Bracket. **DO NOT** drill through pinch weld at this time, (see **STEP 8**).

#### Driver/Left Side Installation Pictured

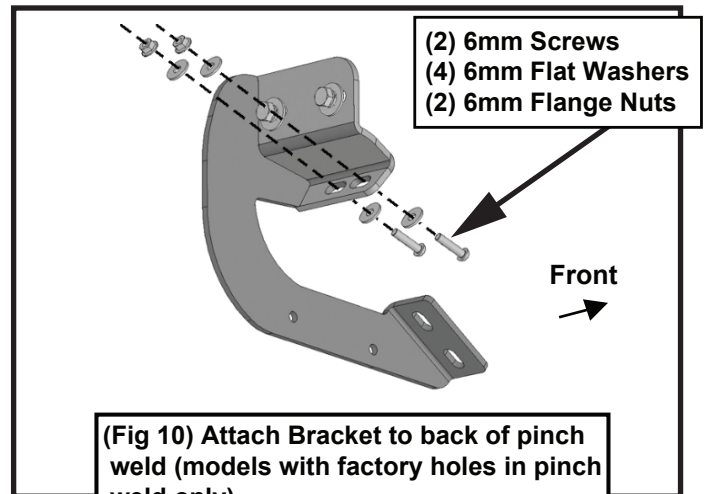

(Fig 10) Attach Bracket to back of pinch weld (models with factory holes in pinch weld only)

(2) 6mm Screws  
(4) 6mm Flat Washers  
(2) 6mm Flange Nuts

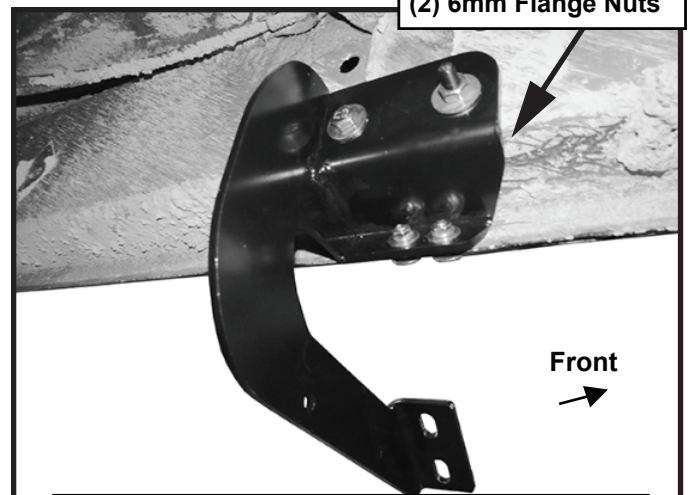

(Fig 11) Attach Bracket to back of pinch weld (models with factory holes in pinch weld only)



## STEP 5

Select (1) Plastic Bracket Cover and (2) Retaining Clips. Slide the Cover over the driver side front Bracket. Line up the (2) mounting holes in the Cover with the holes in the Bracket. Insert the Clips into the holes and push center pins to expand Clips, (Figure 12). Repeat this Step for all Cover installations.

Driver/Left Side Installation Pictured

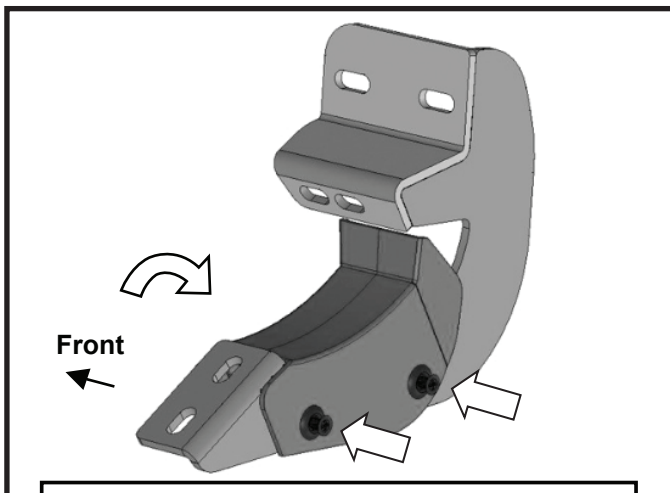

(Fig 12) Slide Cover over top of Bracket. Attach Cover to Bracket with (2) Retaining Clips

## STEP 6

Move to the rear location, (Figure 13). Select the driver/left rear Mounting Bracket. Repeat **STEPS 2—5** to install the rear Mounting Bracket, (Figure 14).

Driver/Left Side Installation Pictured



(Fig 13) Driver/Left rear mounting location

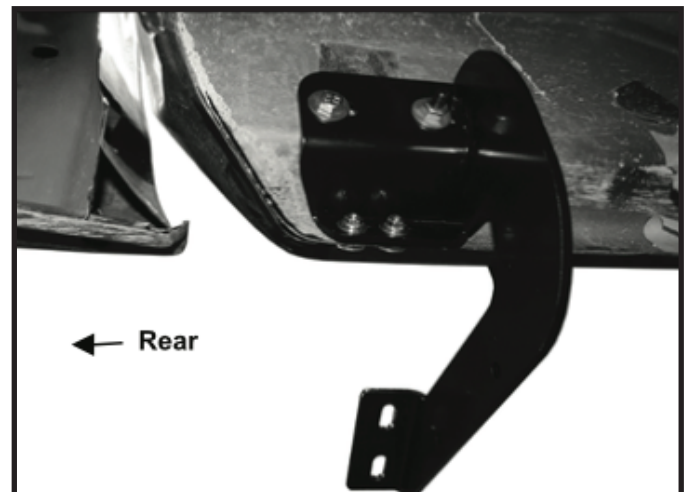

(Fig 14) Driver/Left rear Mounting Bracket assembly

## STEP 7

**IMPORTANT:** DO NOT slide, (front to back or rotate), the Side Step on the Brackets or damage to the finish may result. Attach the Side Step to the (2) Brackets with (4) 8mm Combination Hex Bolts, (Figures 15 & 16). DO NOT fully tighten at this time.



## Driver/Left Side Installation Pictured

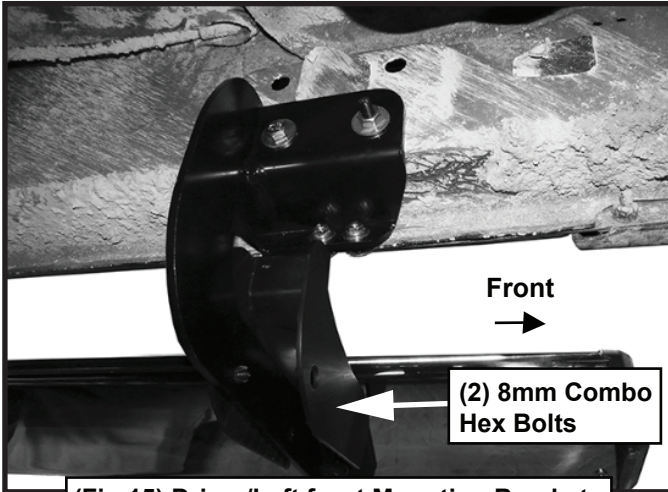

(Fig 15) Driver/Left front Mounting Brackets

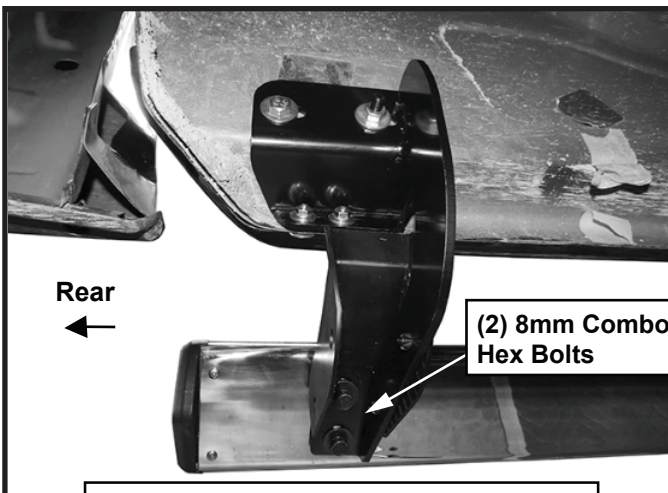

(Fig 16) Driver/left rear Bracket assembly

## STEP 8

Properly level and adjust the Side Step and fully tighten all hardware.

**2009-12 models requiring drilling for driver side Support Brackets:**

- Level the Side Step to the vehicle. Make sure all Brackets are tight against the bottom of the body panel and tighten all mounting hardware.
- Mark the location of the slots onto the pinch weld.
- Drill (2) 1/4" holes through the pinch weld for each Bracket.

**IMPORTANT:** DO NOT drill too close to the bottom edge of the pinch weld. Drill the holes in the center of the marked slots.

- Repeat **STEP 4** to attach the Brackets to the drilled holes in the pinch weld. Check for level then fully tighten all hardware.

## STEP 9

Move to the passenger side of the vehicle. Remove tape covering front and rear locations. Repeat **STEPS 2—8** for passenger/right Side Step installation.

**NOTE:** Refer to the illustration on **PAGE 1** to identify the correct Mounting Bracket for each of the remaining locations.

## STEP 10

Do periodic inspections to the installation to make sure that all hardware is secure and tight.



Complete Installation