



TYGER®

TYGER RISER™

Part#: TG-RS2D40078
FOR 2009-UP DODGE RAM 1500, 2500, 3500 CREW CAB

Parts List

- | | | |
|--|-------------------------------------|--------------------------|
| x1 Driver/left Side Step | x12 8-1.25mm x 30 Hex Bolts | x6 8mm Nut/Bolt Plates |
| x1 Passenger/right Side Step | x12 8mm x 24mm x 2mm Flat Washers | x6 8mm Plastic Retainers |
| x3 Driver/left Front Bracket (also fits passenger/right center and rear locations) | x12 8-1.25mm x 25mm Combo Hex Bolts | x6 8mm Hex Nuts |
| x3 Passenger/right Front Bracket (also fits driver/left center and rear locations) | x12 6-1.0mm x 25mm Socket Head Bolt | x1 Allen Key |
| x6 Plastic Bracket Covers | x24 6mm x18mm x 1.6mm Flat Washers | |
| x12 Plastic Clips for Covers | x12 8mm Lock Washers | |
| | x12 6mm Flange Nuts | |

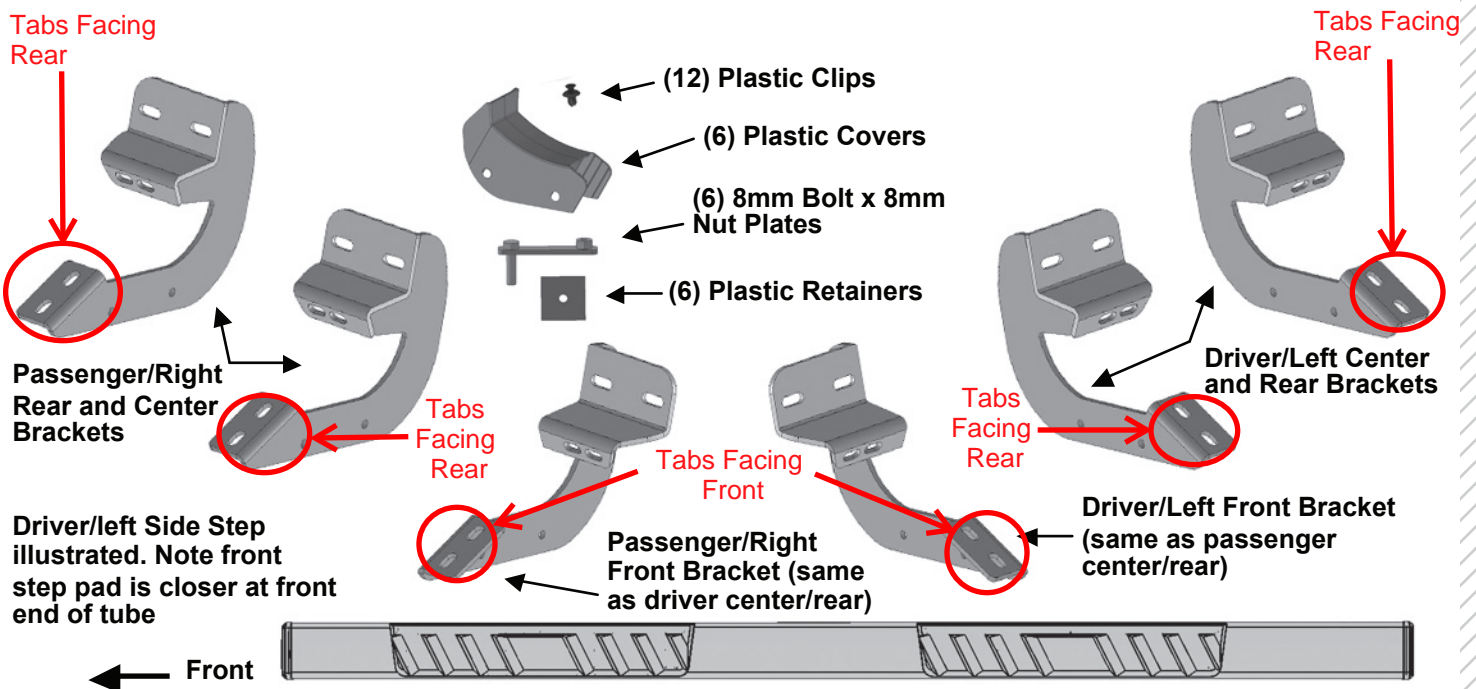



Before Installation

REMOVE CONTENTS FROM BOX. VERIFY ALL PARTS ARE PRESENT. READ INSTRUCTIONS CAREFULLY BEFORE STARTING INSTALLATION. DRILLING MAY BE REQUIRED.

STEP 1

Starting at the driver side-front of the vehicle, remove the sealing tape covering the factory holes in the side of the inner panel, (Figure 1).

STEP 2

Determine the correct procedure to attach the driver side front Bracket for your model/year:

Models without factory threaded inserts in body panel:

a. Select (1) 8mm Bolt/nut Plate, (Figure 2). Partially thread an 8mm Hex Bolt onto the threaded end of the Nut Plate, (Figure 3). Thread the Hex Bolt in until it is flush with the welded nut. Use the Hex Bolt as a handle and insert the Bolt and Nut Plate into the oval hole, (Figure 4). Feed the threaded end of the bolt through one of the hex shaped factory holes.

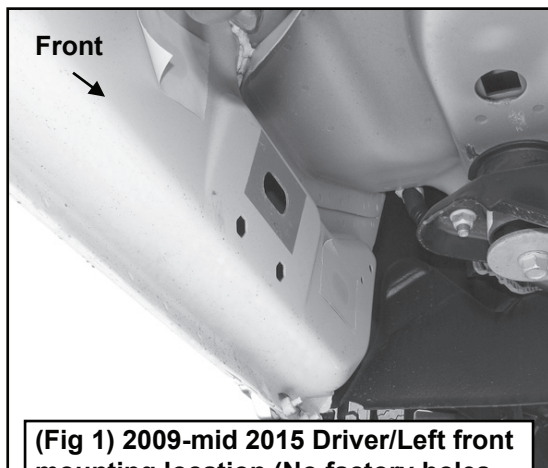

(Fig 1) 2009-mid 2015 Driver/Left front mounting location (No factory holes in pinch weld on some models)



(Fig 2) 8mm Bolt-8mm Nut Plate, NOTE: 8mm Bolt-Nut Plate is not required on models with threaded inserts



(Fig 3) Thread (1) 8mm Hex Bolt into the nut on the plate. Stop when bolt reaches end of nut as pictured

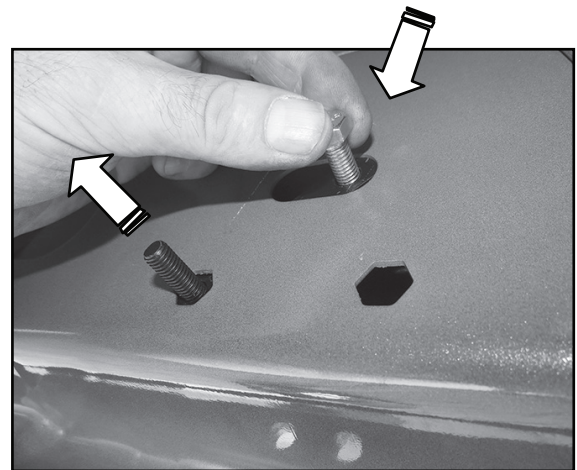

(Fig 4) Use the loose Hex Bolt as a handle. Insert the Bolt Plate into the oval hole and feed the threaded end out either factory hex shaped hole. IMPORTANT: Do not let go of the hex bolt until after Plastic Retainer has been threaded onto bolt (Fig 5)



b. Thread (1) 8mm Plastic Retainer onto the threaded end and down tight against the body panel, (Figure 5). NOTE: The Plastic Retainer is designed to keep the Bolt/Nut Plate from falling into the body panel and to aid in Bracket installation.

c. Select the driver side front Mounting Bracket, (Figure 6). Attach the Bracket to the threaded end of the Bolt Plate with (1) 8mm Flat Washer, (1) 8mm Lock washer and (1) 8mm Hex Nut, (Figure 7). IMPORTANT: Driver/left front Bracket is the same as the passenger/right center and rear Brackets. Do not tighten hardware at this time.

d. Remove the 8mm Hex Bolt from the nut on the Bolt Plate from Step 2a. Rotate the Bolt on the Bolt Plate until the threaded nut lines up with the remaining hole in the Mounting Bracket and body panel, (Figure 7). Attach the Bracket to the threaded Nut Plate with (1) 8mm x 30mm Hex Bolt, (1) 8mm Lock Washer and (1) 8mm Flat Washer, (Figure 7). Do not tighten hardware.

Models with factory threaded inserts:

a. Attach the driver side Front Bracket to the threaded inserts with (2) 8mm x 30mm Hex Bolts, (2) 8mm Lock Washers and (2) 8mm Flat Washer, (Figures 8 & 9). Leave hardware loose.

STEP 3

Next, attach the Bracket to the back of the pinch weld with (2) 6mm x 25mm Socket Head Screws, (4) 6mm Flat Washers and (2) 6mm Flange Nuts, (Figures 10 & 11). Do not fully tighten hardware at this time. IMPORTANT: Some models are not equipped with factory holes and will require drilling through the pinch weld to attach the Support Bracket. Do not drill through pinch weld at this time, (see Step 7).

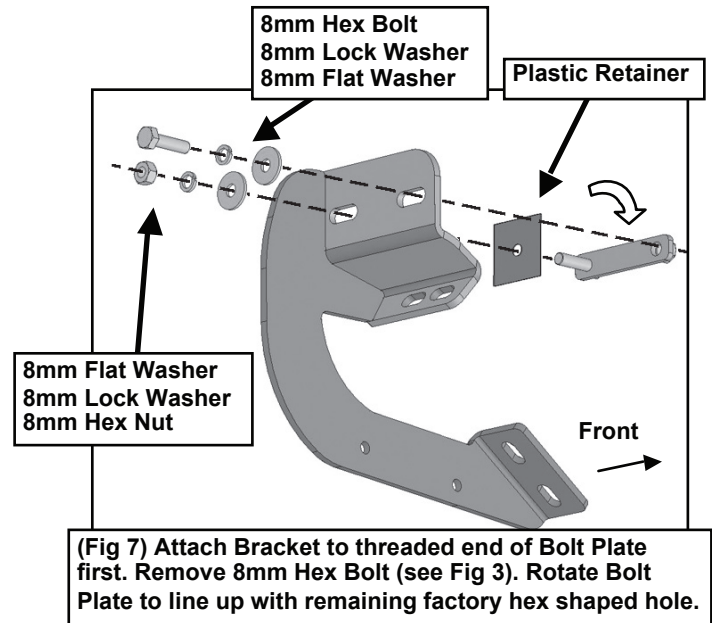
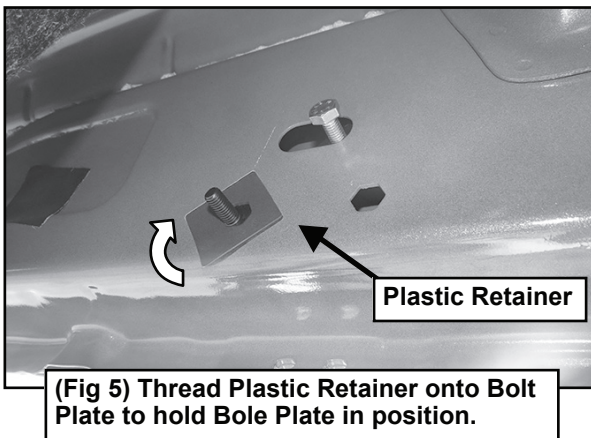
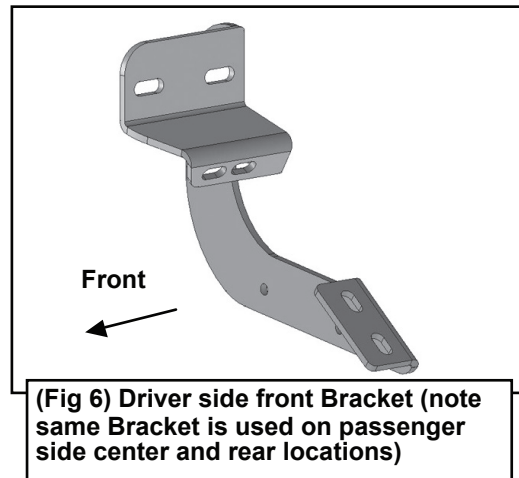



TYGER[®]

STEP 4

Select (1) Plastic Bracket Cover and (2) Retaining Clips. Slide the Cover over the driver side front Bracket. Line up the (2) mounting holes in the Cover with the holes in the Bracket. Insert the Clip into the holes and push center pin to expand Clip, (Figure 12). Repeat this Step for all Cover installation.

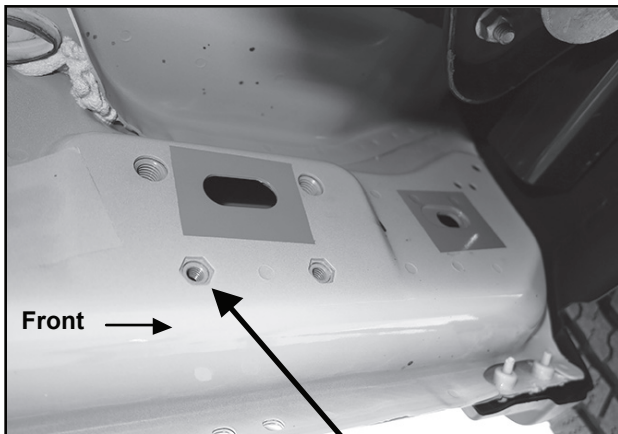

(Fig 8) Driver side front mid 2015-on, an example of models with factory installed threaded inserts

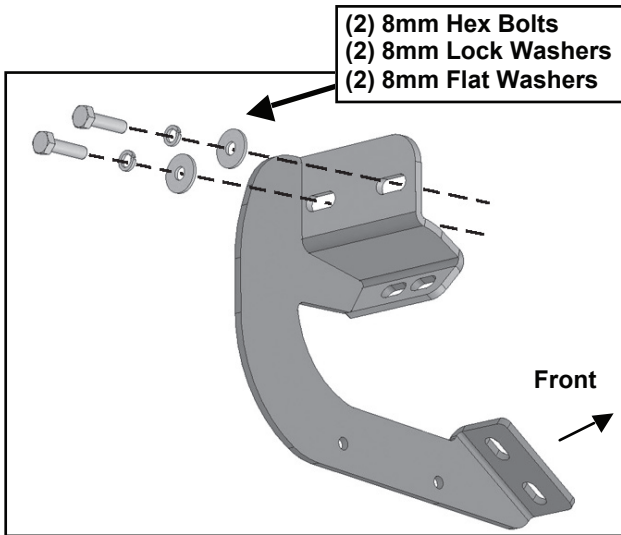

(Fig 9) Driver side front models with factory installed threaded inserts. Bolt Plate not required

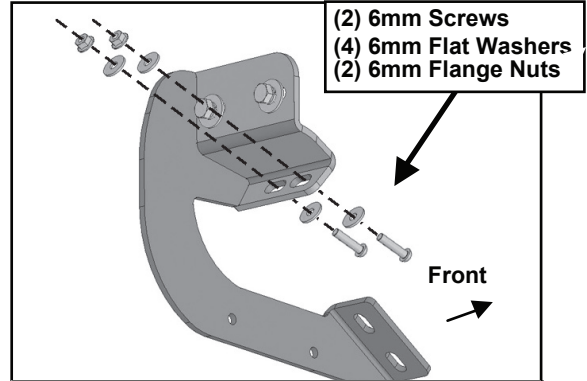

(Fig 10) Attach Bracket to back of pinch weld (models with factory holes in pinch weld only)

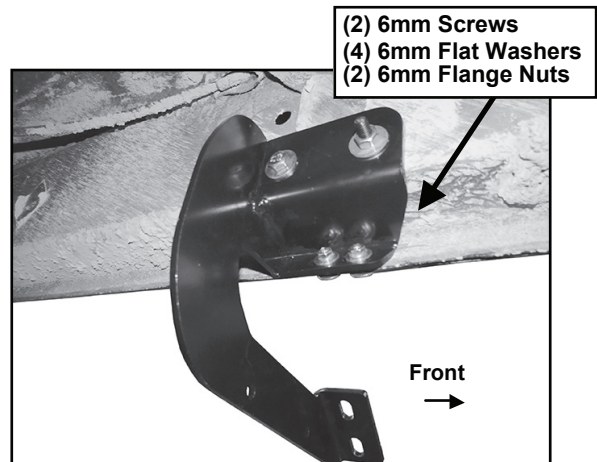

(Fig 11) Attach Bracket to back of pinch weld (models with factory holes in pinch weld only)

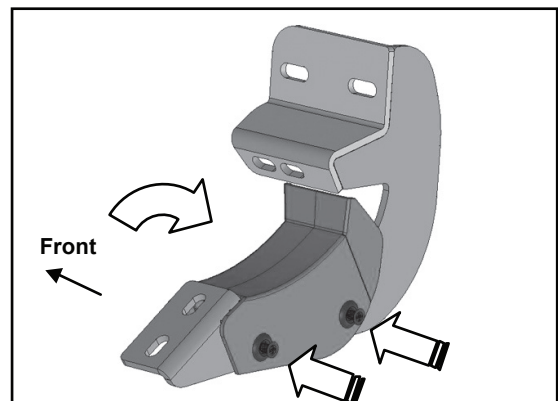

(Fig 12) Slide Cover over top of Bracket. Attach Cover to Bracket with (2) Retaining Clips



STEP 5

Move along the side of the body panel to the center mounting location, (Figure 13). Repeat the appropriate Steps 1- 4 to install the driver side center Bracket, (Figure 14). **IMPORTANT:** The front bracket is different from the center and rear Mounting Brackets, (see illustration above-note direction of mounting plate).

STEP 6

Move to the rear location, (Figure 15). Repeat Step 5 to install the rear Mounting Bracket, (Figure 16).

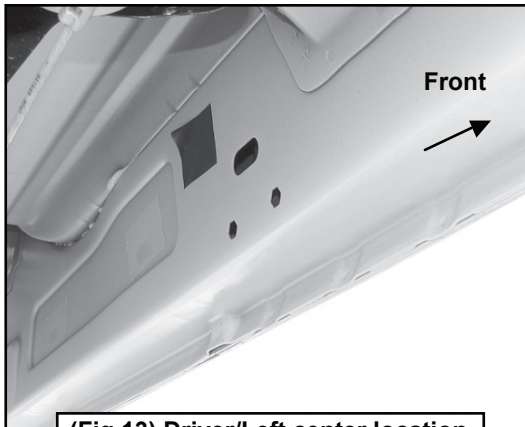

(Fig 13) Driver/Left center location

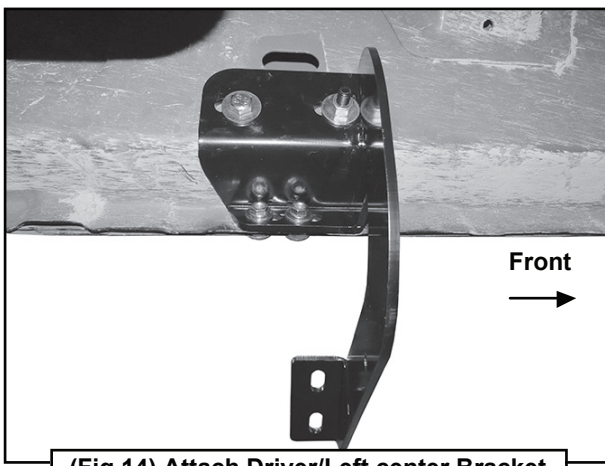

(Fig 14) Attach Driver/Left center Bracket

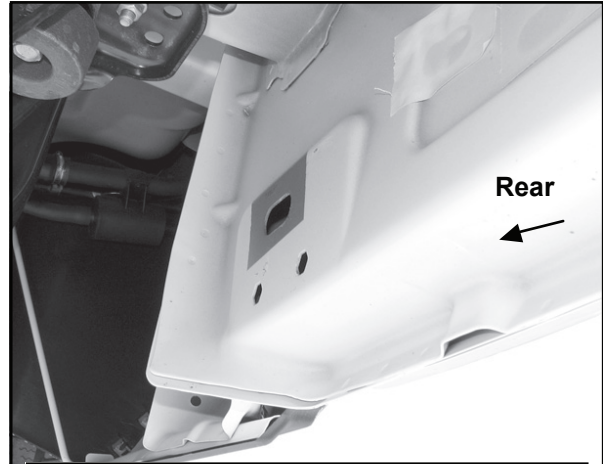

(Fig 15) Driver/Left rear mounting location

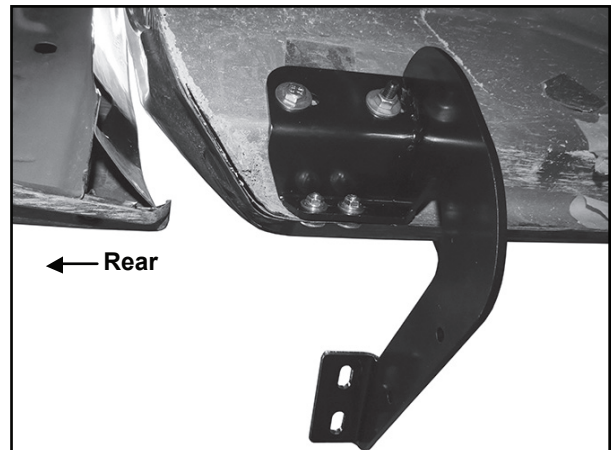

(Fig 16) Driver/Left rear Mounting Bracket assembly

IMPORTANT: Some models without holes in in pinch weld will require drilling 1/4" holes through pinch weld to attach driver side front support bracket. Do complete installation of side armors first, level side armor before drilling holes for support bracket.



STEP 7

Select the driver/left Sidebar. Carefully position the Driver Sidebar onto the (3) Mounting Brackets. **IMPORTANT:** Do not slide, (front to back or rotate), the Sidebar on the Brackets or damage to the finish on the Sidebar may result. Attach the Side Step to the (3) Brackets with (6) 8mm Combination Hex Bolts, (Figures 17-19). Do not fully tighten at this time.

STEP 8

Properly level and adjust the Sidebar and fully tighten all hardware.

Some models requiring drilling for driver side Support Brackets

- Level the Side Step to the vehicle. Make sure all (3) Brackets are tight against the bottom of the body panel and tighten all mounting hardware.
- Mark the location of the slots onto the pinch weld.
- Drill (2) 1/4" holes through the pinch weld for each Support Bracket. **IMPORTANT:** Do not drill too close to the bottom edge of the pinch weld. Drill the holes in the center of the marked slots.
- Repeat Step 3 to attach the Brackets to the drilled holes in the pinch weld. Check for level then fully tighten all hardware.

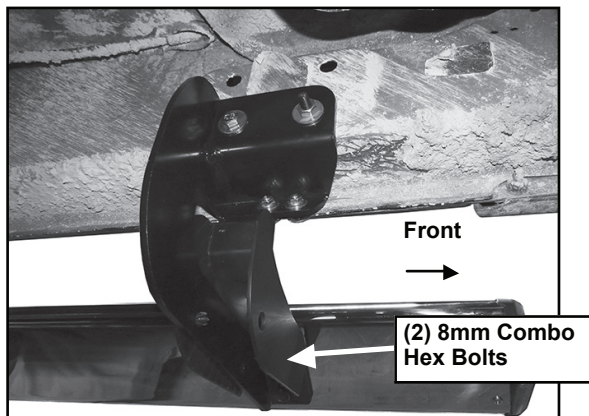

(Fig 17) Driver/Left front Mounting Brackets

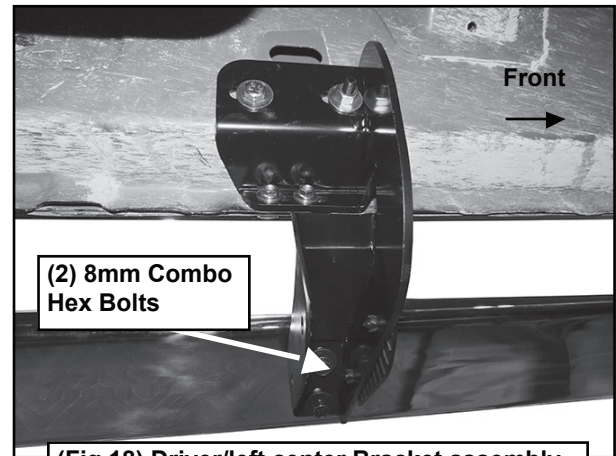

(Fig 18) Driver/left center Bracket assembly

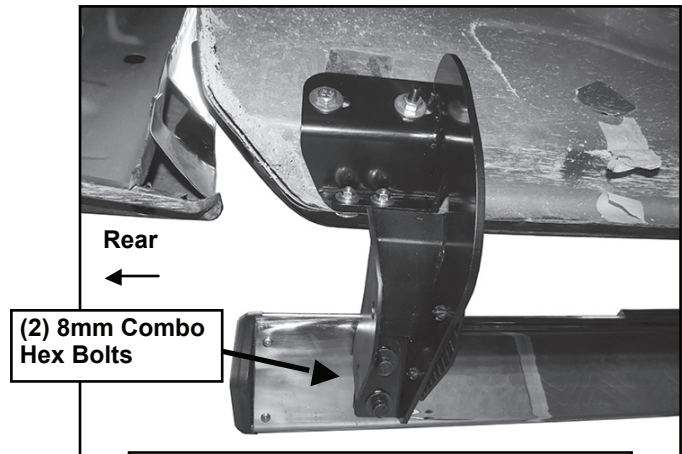

(Fig 19) Driver/left rear Bracket assembly

IMPORTANT: Some models without holes in in pinch weld will require drilling 1/4" holes through pinch weld to attach driver side front support bracket. Do complete installation of side armors first, level side armor before drilling holes for support bracket.



TYGER®

STEP 9

Move to the passenger side of the vehicle. Remove tape covering front, center and rear locations. Repeat Steps 1-8 for passenger side Mounting Bracket installation. NOTE: Refer to the illustration on Page 1 to identify the correct Mounting Bracket for each of the remaining locations.

STEP 10

Do periodic inspections to the installation to make sure that all hardware is secure and tight.

NOTE:

- **TO PROTECT YOUR INVESTMENT:**

Wax this product after installing. Regular waxing is recommended to add a protective layer over the finish. Do not use any type of polish or wax that may contain abrasives that could damage the finish.

- **FOR STAINLESS STEEL:**

Aluminum polish may be used to polish small scratches and scuffs on the finish. Mild soap may be used also to clean the Side Step.

- **FOR GLOSS BLACK FINISHES:**

Mild soap may be used to clean the Side Step.



Installation Complete