



TYGER[®]

TYGER RISER[™]

Part#: TG-RS2D40058
FOR 02-08 DODGE RAM 1500 QUAD CAB &
03-09 RAM 2500-3500 QUAD CAB

Parts List

- x1** Driver/left Side Step
- x1** Passenger/right Side Step
- x1** Driver/Left Front Mounting Bracket
- x1** Passenger/Right Front Mounting Bracket
- x1** Driver/Left Rear Mounting Bracket
- x1** Passenger/Right Rear Mounting Bracket
- x1** Driver/Left Front Support Bracket (long)
- x1** PS/Right Front Support Bracket (long)
- x1** Driver/Left Rear Support Bracket (short)
- x1** PS/Right Rear Support Bracket (short)
- x4** 10mm x 35mm Bolt Plates
- x4** 12-1.75mm x 120mm Gr.10.9 Hex Bolts
- x4** 12mm x 32mm OD x 3mm Flat Washers
- x4** 10-1.5mm x 30mm Hex Bolts
- x12** 10mm x 30mm OD x 2.5mm Flat Washers
- x8** 8-1.25mm x 25mm Combo Hex Bolts
- x4** 14mm Square Spacer
- x4** 10mm Plastic Retainers
- x4** 12mm Lock Washers
- x8** 10mm Nylon Lock Nuts
- x4** Plastic Cover
- x8** Plastic Clip

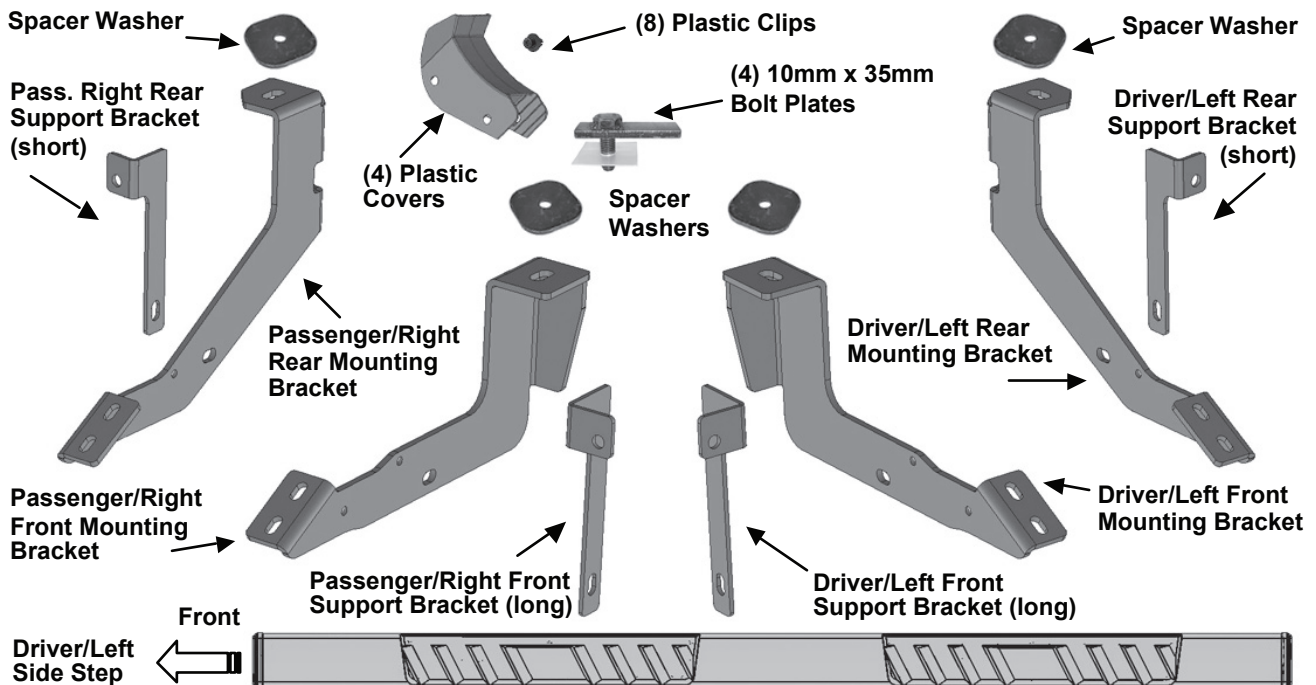



Before Installation

REMOVE CONTENTS FROM BOX. VERIFY ALL PARTS ARE PRESENT. READ INSTRUCTIONS CAREFULLY BEFORE STARTING INSTALLATION. ASSISTANCE IS RECOMMENDED. ON MODELS WITH DEF TANK, SELECT A FLAT, LEVEL AREA FOR INSTALLATION.

STEP 1

Starting toward the front of the passenger side, remove the factory front body mount bolt with washer, (Figure 1). Remove but do not discard the rubber bushing from the factory bolt.

STEP 2

Select the passenger side front Mounting Bracket, (Figure 9). Insert (1) 12mm x 120mm Hex Bolt with (1) 12mm Flat Washer and (1) 12mm Lock Washer through the Mounting Bracket. Place (1) Large Spacer Washer, (Figure 2 & 3), onto the Bolt then slide the rubber bushing onto the Hex Bolt against the Washer. Make sure that the Spacer Washer is between the Bracket and the factory rubber bushing, (Figure 4).



(Fig 2) Spacer Washer



(Fig 3) Passenger/rear Bracket for example only

IMPORTANT: Insert (1) Spacer Washer between each front and rear Mounting Bracket and factory rubber bushing (passenger side front Mounting Bracket pictured)

Remove body mount bolt and washer

Remove sealing tape to uncover mounting hole

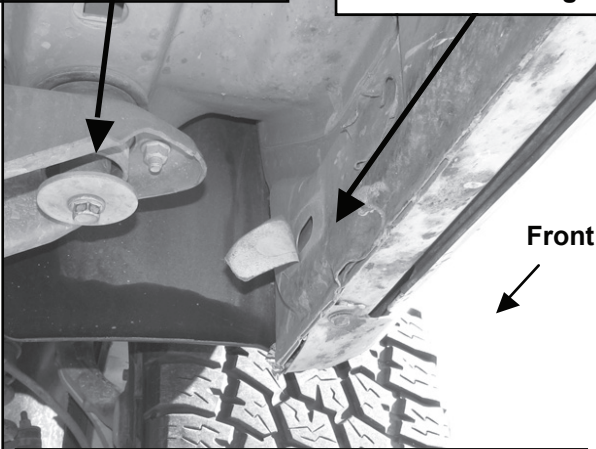

(Fig 1) Passenger side front body mount

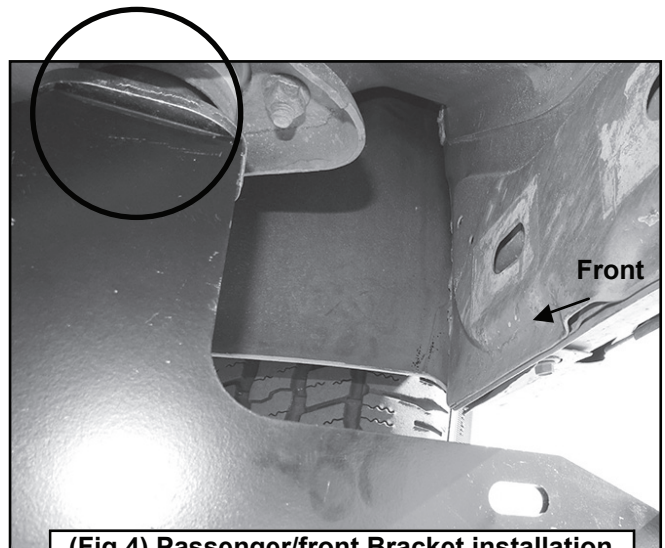

(Fig 4) Passenger/front Bracket installation



STEP 3

Hold the Bracket and hardware up in place and attach to the factory body mount, (Figure 4). Snug but do not tighten hardware at this time. **IMPORTANT:** On 2005 and newer model years, the large washer on the factory body mount bolt may be removable, (do not discard-must reinstall), and the bolt is long enough to go through the Mounting Bracket and properly thread into the body mount. It is the installer's responsibility to check length and to determine whether to reuse the factory body bolt or the included replacement 12mm x 120mm Hex Bolt.

STEP 4

Remove the tape covering the factory hole in the back side of the lower body panel near the Mounting Bracket, (Figure 4). Thread (1) Plastic Retainer part way onto (1) 10mm x 35mm Bolt Plate, (Figure 5). Insert the Bolt Plate into the factory hole on the body panel, (Figure 6). Hold the Bolt Plate in place with one hand and continue to thread the Plastic Retainer down against the sheet metal to hold the Bolt Plate in place, (Figure 7). **IMPORTANT:** The Plastic Retainer is designed to prevent the Bolt Plate from falling into the body panel and to aid in Bracket installation.

STEP 5

Select the passenger side front Support Bracket (long), (Figure 8). Attach the Bracket to the Bolt Plate with (1) 10mm Flat Washer, (1) 10mm Lock Washer and (1) 10mm Hex Nut, (Figure 9). **NOTE:** Place the lower flat end of the Support Bracket against the front facing side of the Mounting Bracket. The bent tab on the top of the Support Bracket should face the front of the vehicle. Do not tighten hardware.

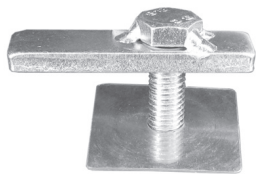

(Fig 5) Bolt Plate w/Retainer

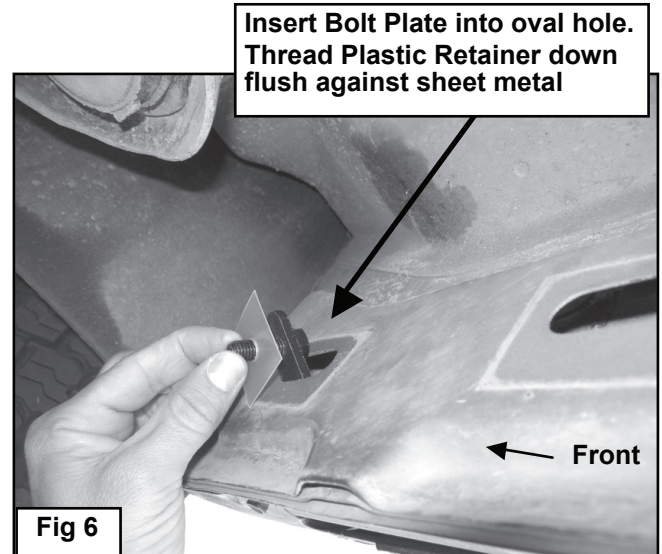

Fig 6

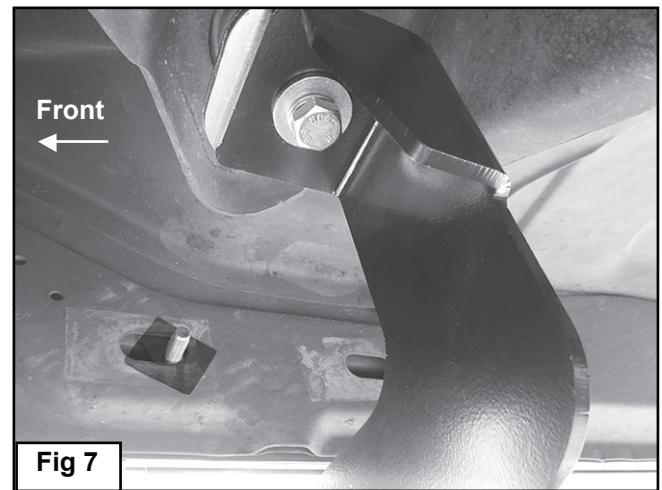

Fig 7

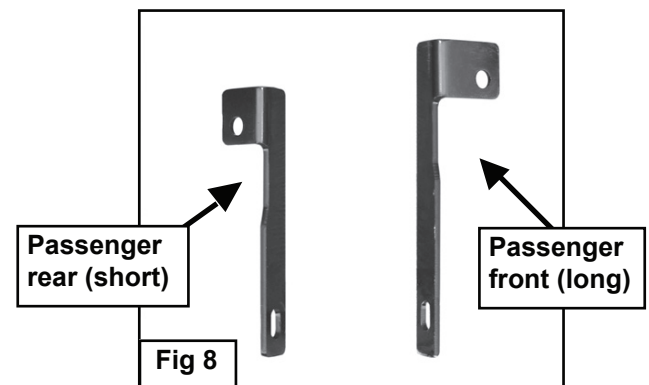

Fig 8



STEP 6

Attach the flat lower end of the front Support Bracket to the front of the Mounting Bracket with (1) 10mm x 30mm Hex Bolt, (2) 10mm Flat Washers, (1) 10mm Lock Washer and (1) 10mm Hex Nut, (Figure 9 & 11). Do not tighten hardware at this time.

STEP 7

Select (1) Plastic Bracket Cover and (2) Retaining Clips, (Figure 10). Slide the Cover over the front Bracket. Line up the mounting holes in the Cover with the holes in the Bracket. Insert (1) Clip into each hole and push center pin to expand Clip. Repeat this Step for all Cover installations.

STEP 8

Move to the rear body mount at the back of the cab. Select the passenger side rear Mounting Bracket. Repeat Steps 1-3 for rear Mounting Bracket installation, (Figures 12 & 14).

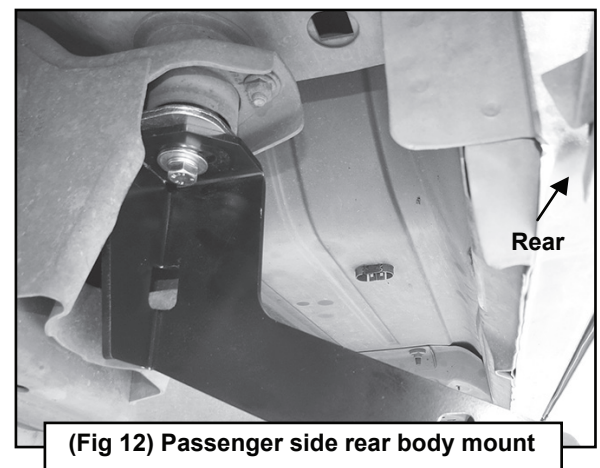
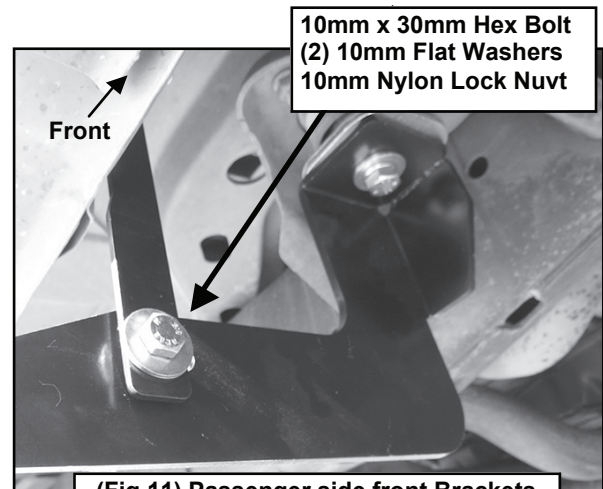
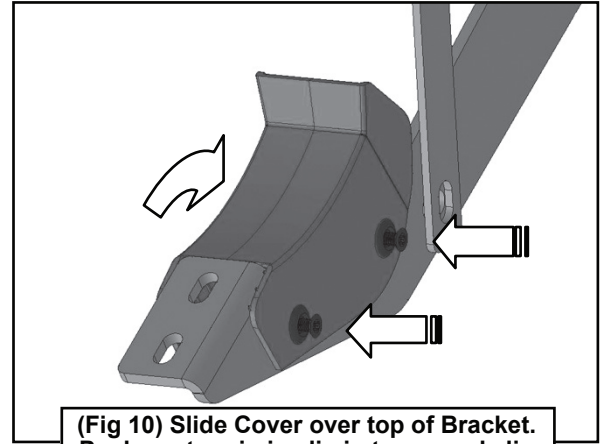
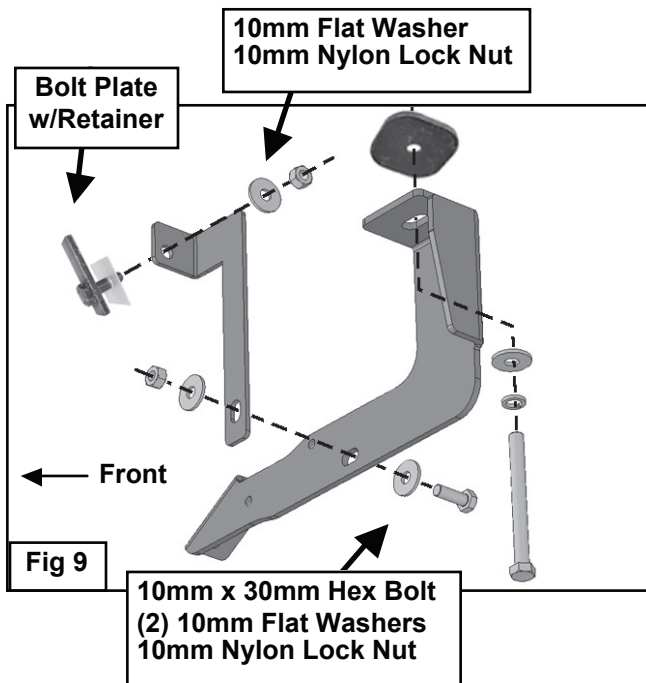



STEP 9

Remove the tape covering the hole in the inner rocker panel and install (1) Bolt Plate as described in Step 4, (Figure 13). Select the passenger side rear Support Bracket, (short), (Figure 8). Attach the bent end of the top of the Bracket to the Bolt Plate with (1) 10mm Flat Washer, (1) 10mm Lock Washer and (1) 10mm Hex Nut, (Figures 13 & 14). NOTE: Place Support Bracket against the front facing side of the Mounting Bracket. The bent tab on the top of the rear Support Bracket should face the rear of the vehicle.

STEP 10

Repeat Step 6 to attach the flat lower end of the Support Bracket to the front of the rear Mounting Bracket, (Figure 14). Snug but do not tighten hardware at this time

STEP 11

Repeat Step 7 to install the Plastic Cover over the Bracket, (Figure 10).

STEP 12

Select the passenger/right Side Step. Carefully position the Side Step onto the (3) Brackets. IMPORTANT: Do not slide, (front to back or rotate), the Side Step on the Brackets or damage to the finish may result. Attach the Side Step to the Brackets with (6) 8mm x 25mm Combo Hex Bolt assemblies, (Figure 15). Do not tighten hardware.

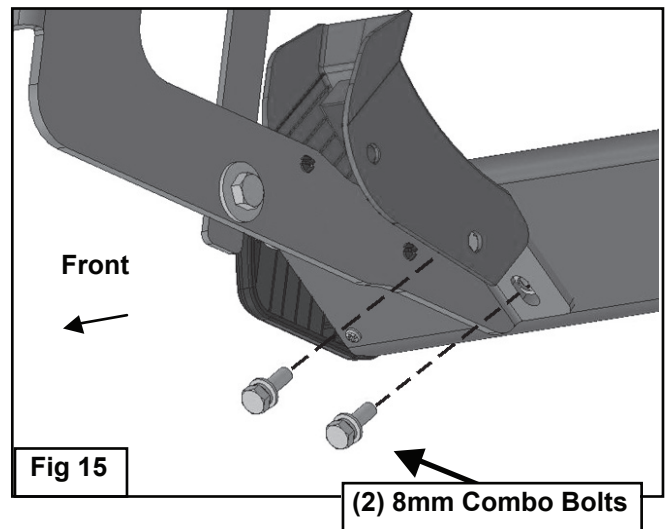
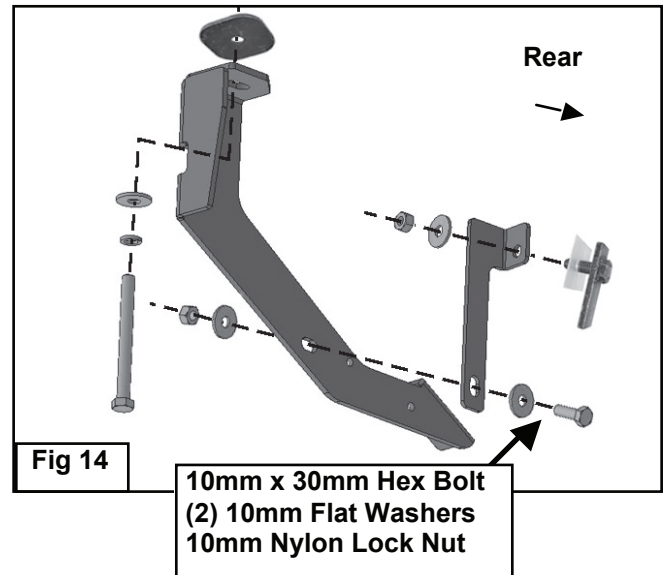
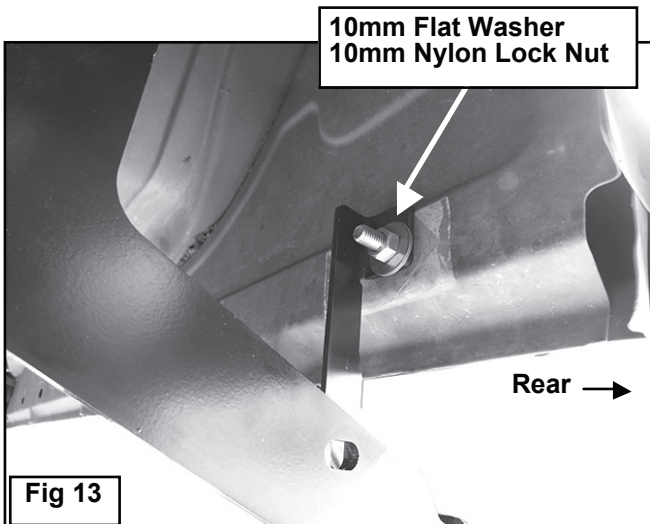



TYGER[®]

STEP 13

Level and adjust the Side Step and tighten all hardware.

STEP 14

Repeat Steps 1-13 for the driver/left Side Step installation.

STEP 15

Do periodic inspections to the installation to make sure that all hardware is secure and tight.

NOTE:

- **TO PROTECT YOUR INVESTMENT:**

Wax this product after installing. Regular waxing is recommended to add a protective layer over the finish. Do not use any type of polish or wax that may contain abrasives that could damage the finish.

- **FOR STAINLESS STEEL:**

Aluminum polish may be used to polish small scratches and scuffs on the finish. Mild soap may be used also to clean the Side Step.

- **FOR GLOSS BLACK FINISHES:**

Mild soap may be used to clean the Side Step.

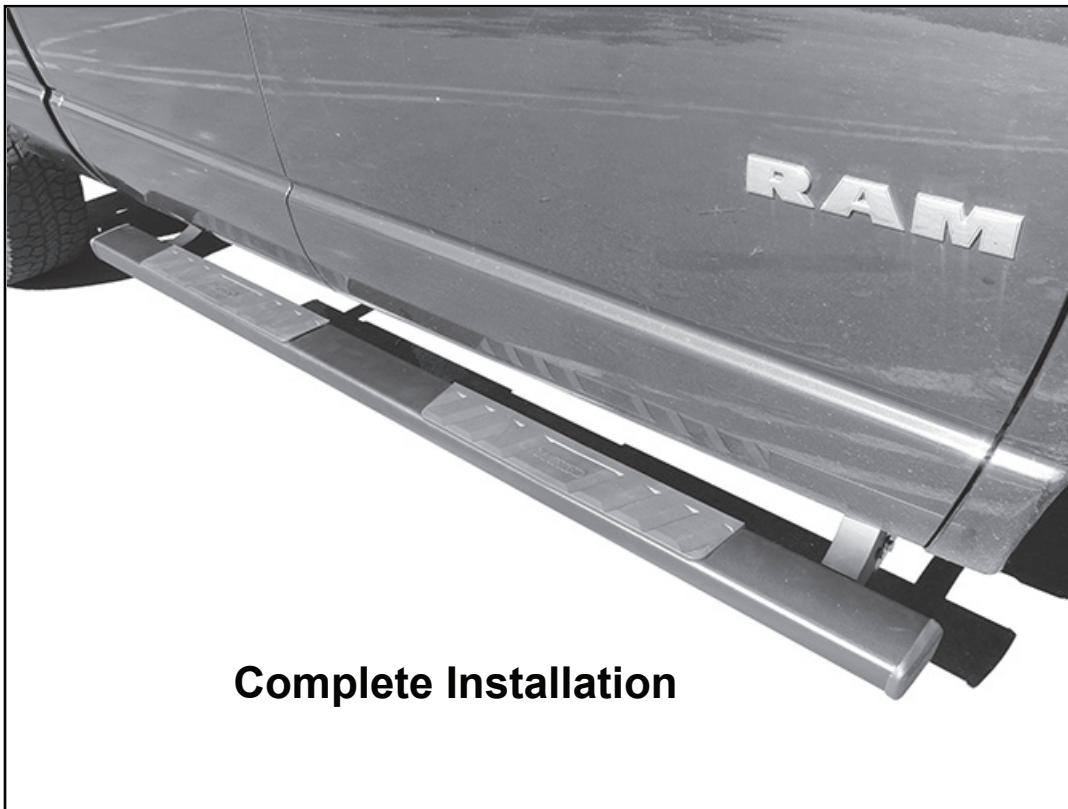

Complete Installation