



RISER®

TG-RS2C40248

BEFORE INSTALLATION

READ INSTRUCTIONS CAREFULLY BEFORE STARTING INSTALLATION. REMOVE CONTENTS FROM BOX AND VERIFY ALL PARTS ARE PRESENT. FAILURE TO IDENTIFY DAMAGE BEFORE INSTALLATION COULD LEAD TO A REJECTION OF ANY CLAIM. IF MISSING PARTS OR ANY DAMAGE FOUND, PLEASE TAKE A PICTURE FOR THE CLAIM PURPOSE.

TORQUE VALUES

Fastener Size	Class 8.8 Torque (ft-lbs)	Class 10.9 Torque (ft-lbs)
6mm	6-7	6-7
8mm	15-16	22-23
10mm	31-32	44-45
12mm	54-55	78-79
14mm	87-88	125-126

NOTE: Assistance is recommended.

Parts List

- x1 Driver/left Sidebar
- x1 Passenger/right Sidebar
- x8 Mounting Brackets
- x8 Plastic Bracket Covers
- x16 Retaining Clips (use with Plastic Covers)
- x16 8-1.25mm x 30mm Hex Bolts
- x16 8-1.25mm x 25mm Combo Bolts
- x16 8mm Lock Washers
- x16 8mm x 24mm x 2mm Flat Washers

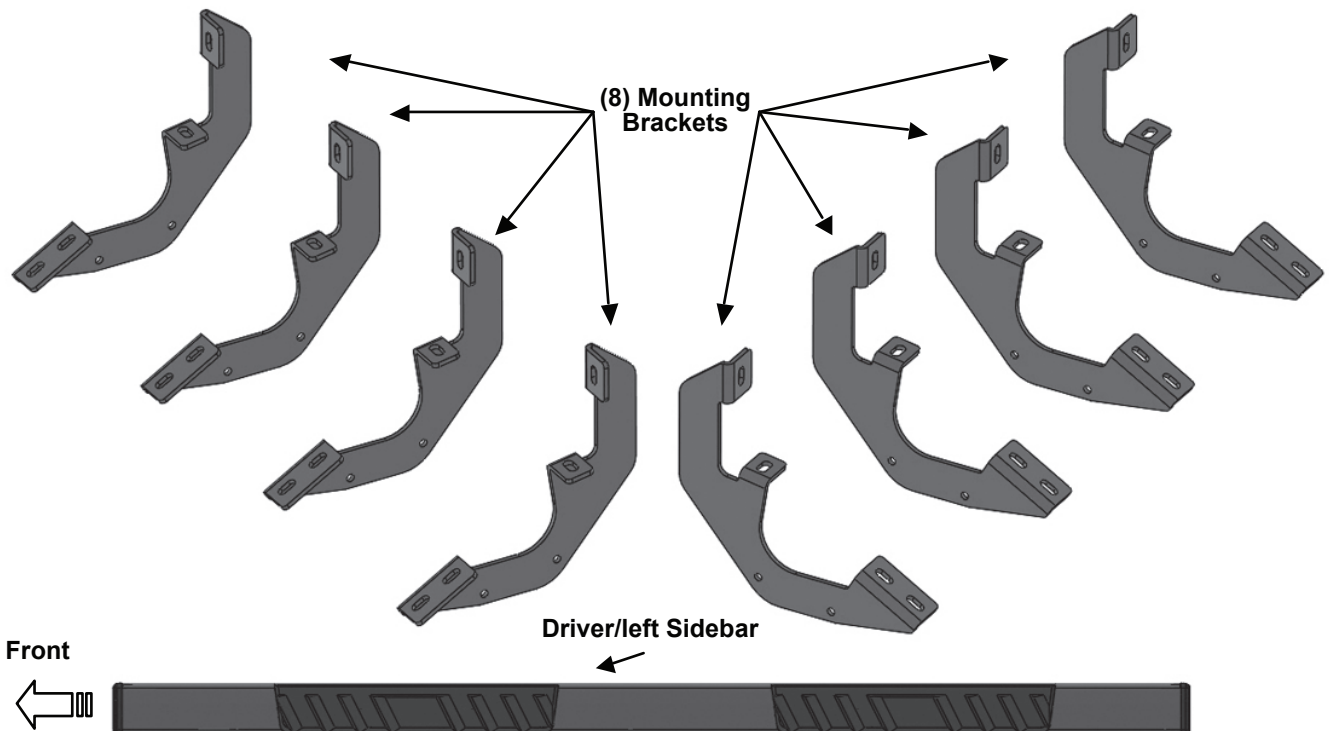



STEP 1

Start the installation under the driver side of the vehicle. Locate the 6 plugs along the bottom edge of the body. Mounting Brackets will bolt to the 1st, 3rd, 4th & 6th threaded mounting holes, (Figs 1-6).

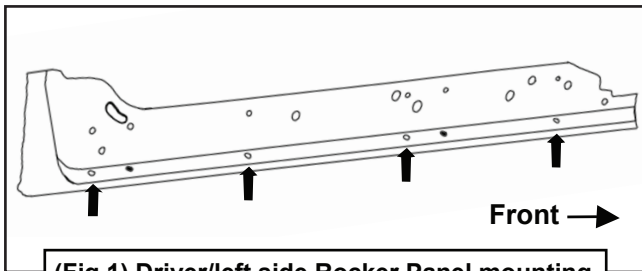

(Fig 1) Driver/left side Rocker Panel mounting locations illustrated (arrows) NOTE: Hold Bracket up to body panel to help determine the correct mounting locations.

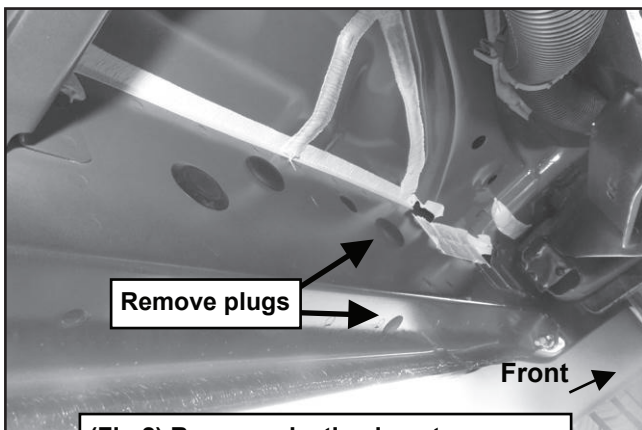

(Fig 2) Remove plastic plugs to uncover threaded inserts

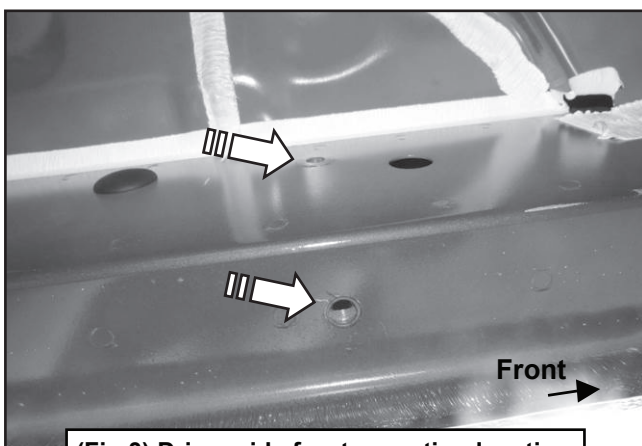

(Fig 3) Driver side front mounting location

Remove the plastic plugs from each mounting location. Directly above each threaded insert is a top mounting location on the side of the body panel. Hold a Bracket up in place to help determine the correct mounting holes to use along the body.

NOTE: Thread an 8mm Hex Bolt into the threaded inserts to clear paint as required.

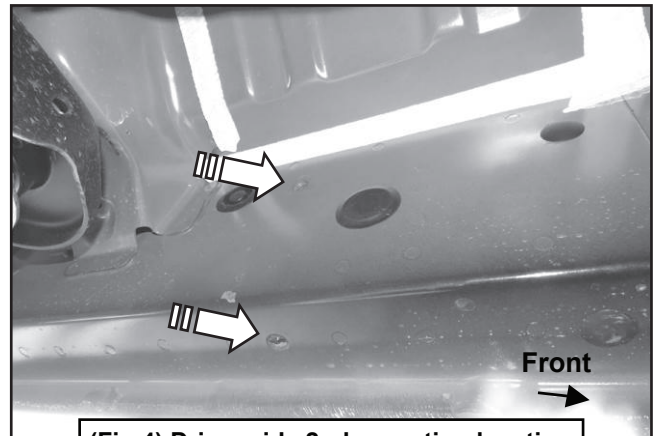

(Fig 4) Driver side 2nd mounting location

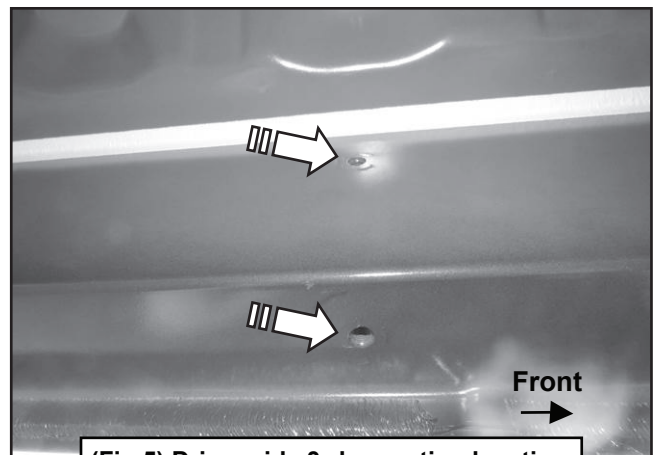

(Fig 5) Driver side 3rd mounting location

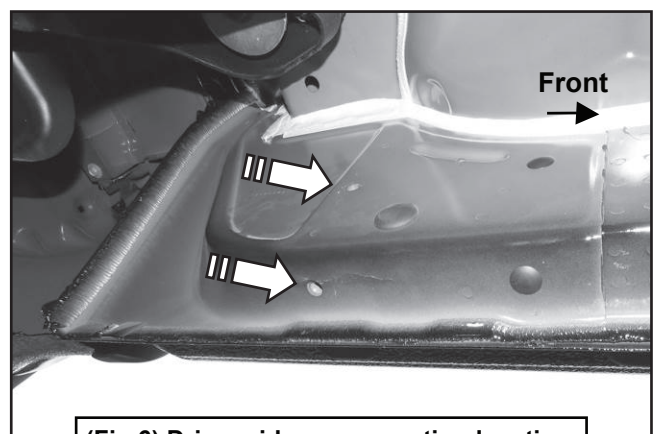

(Fig 6) Driver side rear mounting location



STEP 2

Select (1) Mounting Bracket. Starting at the front of the driver/left side, bolt the Mounting Bracket to the factory threaded holes with (2) 8mm Hex Bolts, (2) 8mm Lock Washers and (2) 8mm Flat Washers, (Fig 7). Do not tighten hardware at this time.

STEP 3

Repeat Steps 1-2 to install (3) Mounting Brackets on the remaining driver/left side mounting locations along the body panel.

STEP 4

Select (1) Plastic Bracket Cover. Slide Plastic Cover over Bracket, (Fig 8). Line up the (2) mounting holes in the Cover with the side holes in the Bracket. Insert (1) Plastic Clip into each hole and push center pin to expand Clip. Repeat this Step for all Brackets.

STEP 5

Select the Driver/left Sidebar. Use the illustration above to help determine the correct Sidebar.

NOTE: The front stepping pad is farther away from the front end of the Sidebar. Place the Sidebar on top of the Brackets.

IMPORTANT: Do not slide, (front to back), the Sidebar on the Brackets or damage to the finish may result.

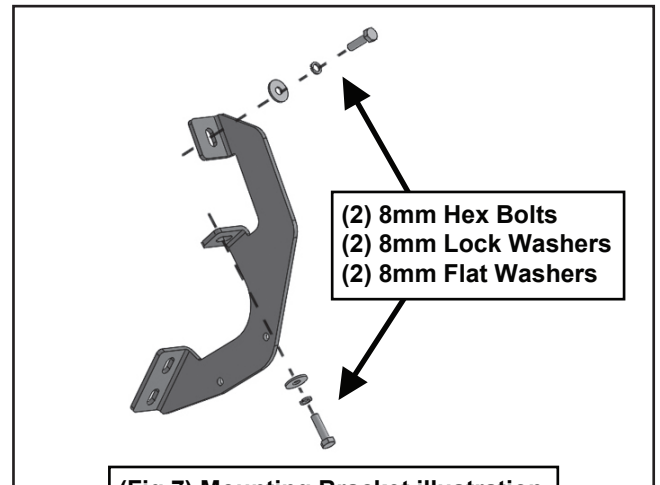

(Fig 7) Mounting Bracket illustration

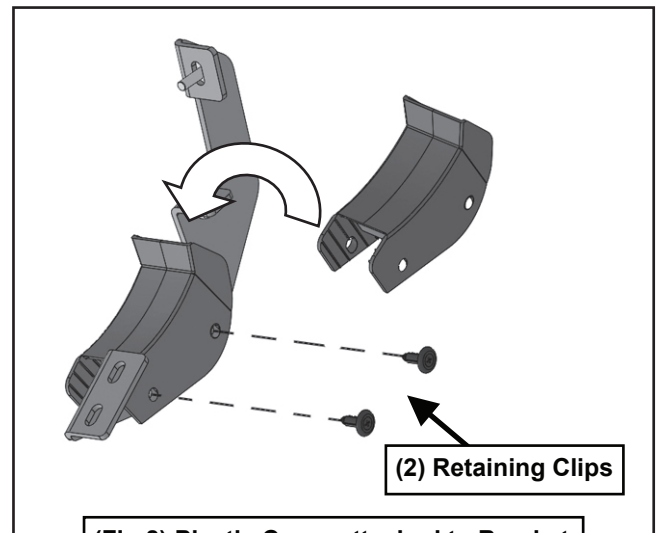

(Fig 8) Plastic Cover attached to Bracket



STEP 6

Attach the Sidebar to the Brackets with (8) 8mm Combo Bolts, (Fig 9).

STEP 7

Level and adjust the Sidebar and fully tighten all hardware.

STEP 8

Repeat Steps 1-7 to install the Passenger/right Sidebar.

STEP 9

Do periodic inspections to the installation to make sure that all hardware is secure and tight.

NOTE:

Mild soap may be used to clean the side step

