



TYGER[®]

TYGER RISER[™]

Part#: TG-RS2C40028
FOR 2015 CHEVY COLORADO/GMC CANYON
EXTRA CAB

Parts List

- | | |
|---|-----------------------------------|
| x1 Driver/left Side Step | x12 Plastic Clips |
| x1 Passenger/right Side Step | x12 8-1.25mm x 25mm Hex Bolts |
| x6 Sidebar Brackets (use for left or right) | x12 8mm x 24mm x 2mm Flat Washers |
| x12 8-1.25mm Clip-On Nuts | x12 8-1.25mm x 25mm Combo Bolts |
| x6 Plastic Covers | x12 8mm Lock Washers |

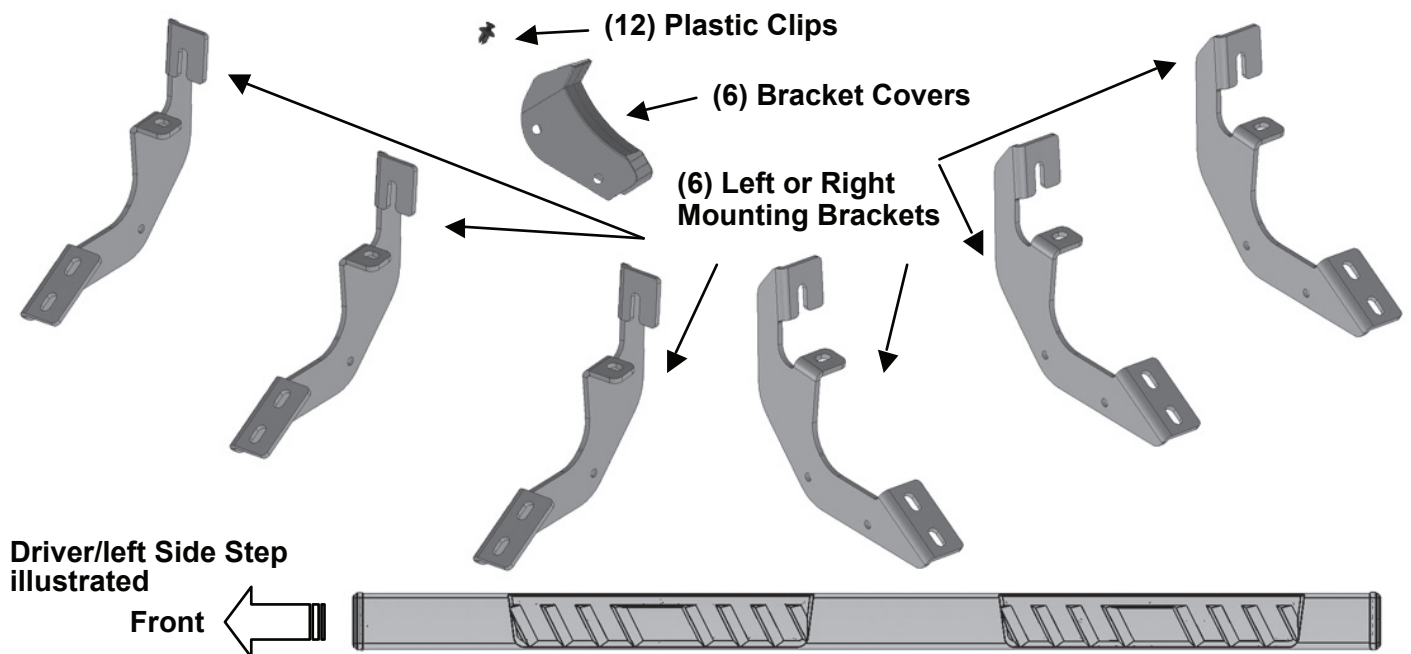



TYGER[®]

Before Installation

REMOVE CONTENTS FROM BOX. VERIFY ALL PARTS ARE PRESENT. READ INSTRUCTIONS CAREFULLY BEFORE STARTING INSTALLATION. ASSISTANCE IS RECOMMENDED. ON MODELS WITH DEF TANK, SELECT A FLAT, LEVEL AREA FOR INSTALLATION.

STEP 1

Start the installation under the passenger side of the vehicle. Locate the 4 factory running board mounting locations along the bottom and inner side of the body, (Figure 1). Mounting Brackets will bolt to the 1st, 2nd and 4th mounting locations. NOTE: It may help to hold a Bracket up in place to help determine the mounting holes to use along the bottom and inner side of the body.

STEP 2

Remove rubber plugs as necessary from the (2) factory mounting holes, (Figure 2). Select (1) 8mm Clip Nut. Slide the Clip Nut into the large hole and over the smaller hole next to it. Line up threaded nut on the Clip Nut with smaller hole in body panel, (Figure 3). Repeat to install a 2nd Clip Nut in the remaining front mounting hole.

STEP 3

Select (1) Mounting Bracket. NOTE: All (6) Brackets are universal and will fit left or right side. Attach the Bracket to the (2) Clip Nuts with (2) 8mm Hex Bolts, (2) 8mm Lock Washers and (2) 8mm Flat Washers, (Figure 4). Snug but do not fully tighten the hardware.

STEP 4

Select (1) Plastic Bracket Cover and (2) Retaining Clips, (Figure 5). Slide the Cover over the front Bracket. Line up the mounting holes in the Cover with the holes in the Bracket. Insert (1) Clip into each hole and push center pin to expand Clip, (Figure 5). Repeat this Step for all Cover installations.

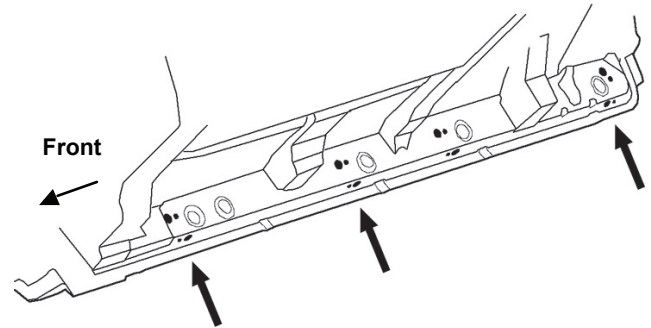

(Fig 1) Passenger side mounting locations along bottom and back of body panel illustrated

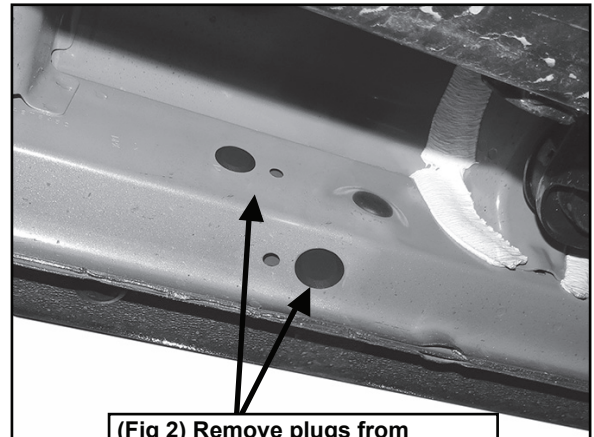

(Fig 2) Remove plugs from mounting locations as necessary

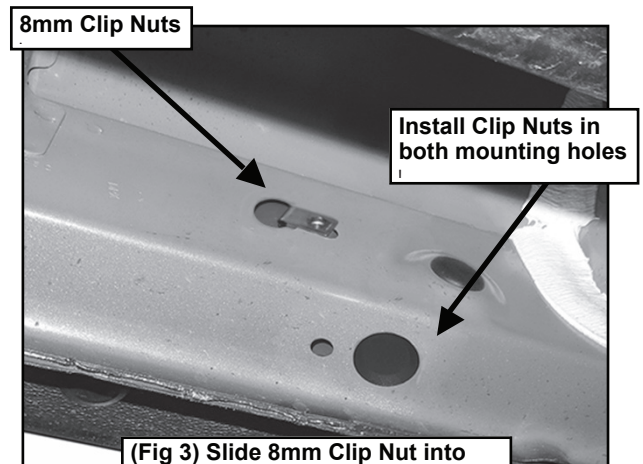

(Fig 3) Slide 8mm Clip Nut into large hole and over small hole



STEP 5

Repeat Steps 2-4 for Center and rear Mounting Bracket installation.

STEP 6

Select the Driver/left Side Step. Carefully position the Side Step onto the (3) Brackets. **IMPORTANT:** Do not slide, (front to back or rotate), the Side Step on the Brackets or damage to the finish may result. Attach the Side Step to the Brackets with (6) 8mm x 25mm Combo Hex Bolt assemblies, (Figure 6). Do not tighten hardware.

STEP 7

Level and adjust the Side Step and tighten all hardware.

STEP 8

Repeat Steps 1—7 to install the driver/left Side Step, (Figure 7).

(2) 8mm x 25mm Hex Bolts
(2) 8mm Lock Washers
(2) 8mm Flat Washers

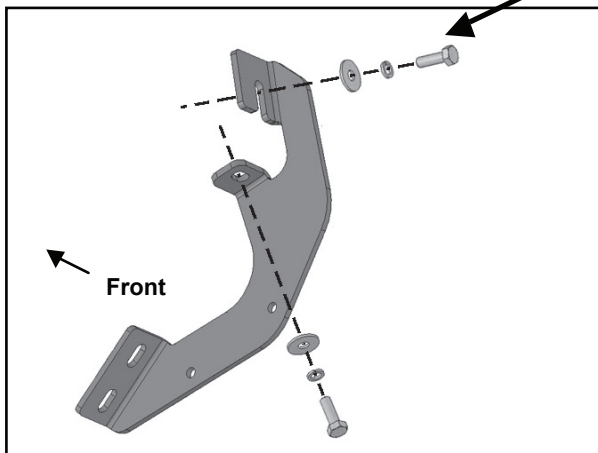

(Fig 4) Passenger side installation pictured

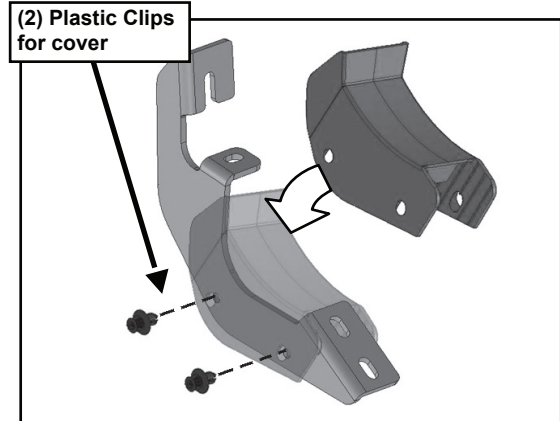

(Fig 5) Passenger front Bracket cover installation

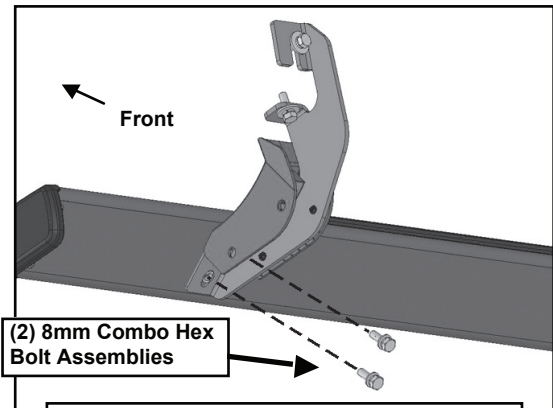

(Fig 6) Passenger front Side Step installation

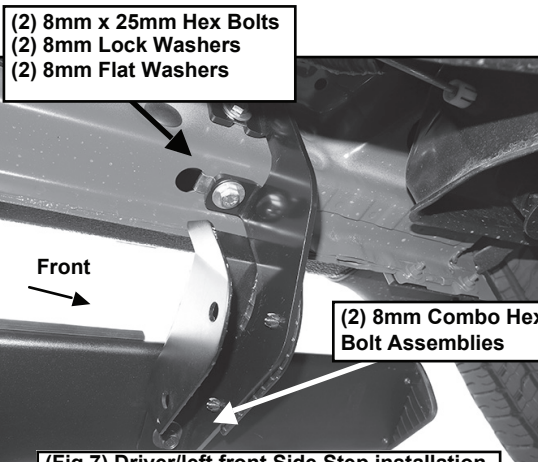

(Fig 7) Driver/left front Side Step installation



TYGER[®]

STEP 9

Do periodic inspections to the installation to make sure that all hardware is secure and tight.

NOTE:

- **TO PROTECT YOUR INVESTMENT:**

Wax this product after installing. Regular waxing is recommended to add a protective layer over the finish. Do not use any type of polish or wax that may contain abrasives that could damage the finish.

- **FOR STAINLESS STEEL:**

Aluminum polish may be used to polish small scratches and scuffs on the finish. Mild soap may be used also to clean the Side Step.

- **FOR GLOSS BLACK FINISHES:**

Mild soap may be used to clean the Side Step.



Complete Installation