



## TYGER LANDER®

TG-LD2J62888

### BEFORE INSTALLATION

READ INSTRUCTIONS CAREFULLY BEFORE STARTING INSTALLATION. REMOVE CONTENTS FROM BOX AND VERIFY ALL PARTS ARE PRESENT. FAILURE TO IDENTIFY DAMAGE BEFORE INSTALLATION COULD LEAD TO A REJECTION OF ANY CLAIM. IF MISSING PARTS OR ANY DAMAGE FOUND, PLEASE TAKE A PICTURE FOR THE CLAIM PURPOSE.

### TORQUE VALUES

Fastener Size	Class 8.8 Torque (ft-lbs)	Class 10.9 Torque (ft-lbs)
6mm	6-7	6-7
8mm	15-16	22-23
10mm	31-32	44-45
12mm	54-55	78-79
14mm	87-88	125-126

### Parts List

- x1 Driver/Left Tyger Lander
- x1 Passenger/Right Tyger Lander
- x1 Driver/Left Front Mounting Bracket
- x1 Passenger/Right Front Mounting Bracket
- x1 Driver/Left Center Mounting Bracket
- x1 Passenger/Right Center Mounting Bracket
- x1 Driver/Left Rear Mounting Bracket
- x1 Passenger/Right Rear Mounting Bracket
- x8 10-1.5mm x 35mm Hex Bolts
- x16 10mm x 27mm OD x 3mm Flat Washers
- x8 10mm Nylon Lock Nuts
- x6 8-1.25mm x 35mm Hex Bolts
- x4 8-1.25mm x 25mm Combo Bolts
- x6 8mm Lock Washers
- x6 8mm x 28mm OD x 3mm Flat Washers
- x12 6-1.0mm x 25mm Hex Bolts
- x24 6mm x 22mm OD x 2mm Flat Washers
- x12 6mm Nylon Lock Nuts

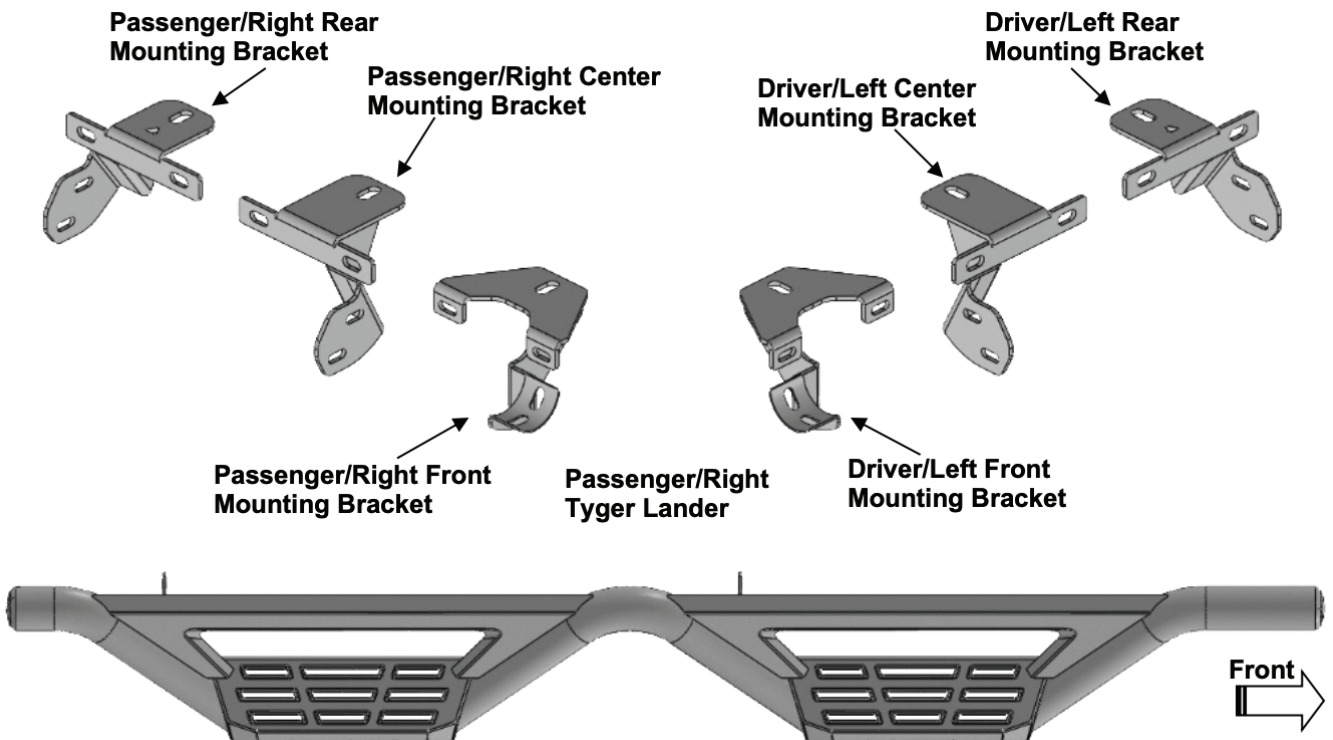



# TYGER<sup>®</sup>

**PROCEDURE: REMOVE CONTENTS FROM BOX. VERIFY ALL PARTS ARE PRESENT. READ INSTRUCTIONS CAREFULLY. FACTORY INSTALLED OR AFTERMARKET SIDE STEPS OR RUNNING BOARDS MUST BE REMOVED. ASSISTANCE IS HIGHLY RECOMMENDED.**

## STEP 1

Start installation on the Passenger/Right side of the vehicle. Locate the (3) pairs of factory mounting holes along the pinch weld. The mounting brackets attach to the holes in the pinch weld and the small factory threaded hole directly behind the pinch weld.

## STEP 2

Move to the front location (Fig 1). Select the Passenger/Right Front Mounting Bracket. Attach the Bracket to the threaded hole on the body panel with (1) 8mm Hex Bolt, (1) 8mm Lock Washer and (1) 8mm Flat Washer (Figs 2 & 3). **DO NOT** tighten hardware at this time.

Passenger/Right Side Installation Pictured

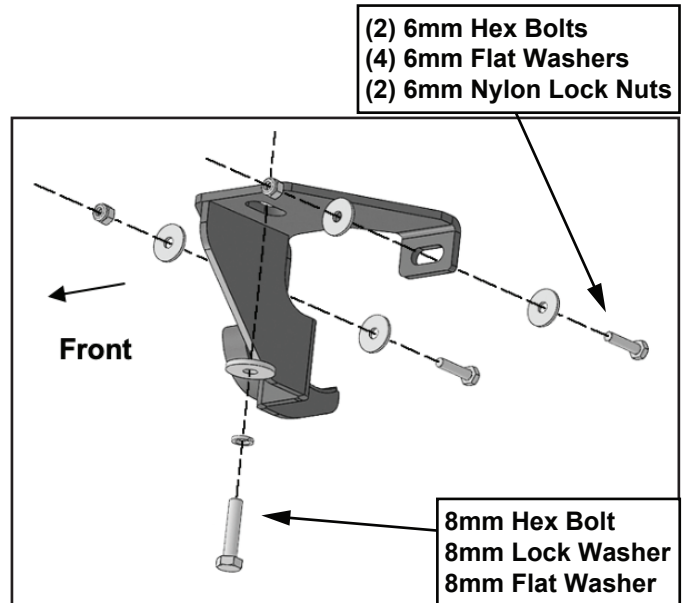
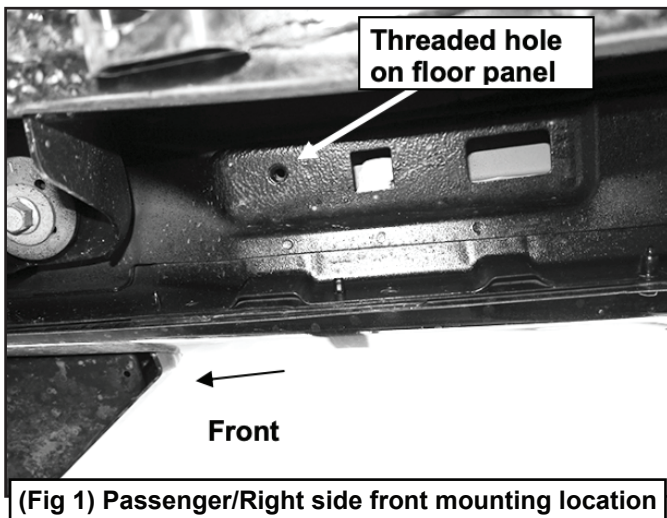

(Fig 2) Attach the Passenger/Right Front Mounting Bracket to the front location

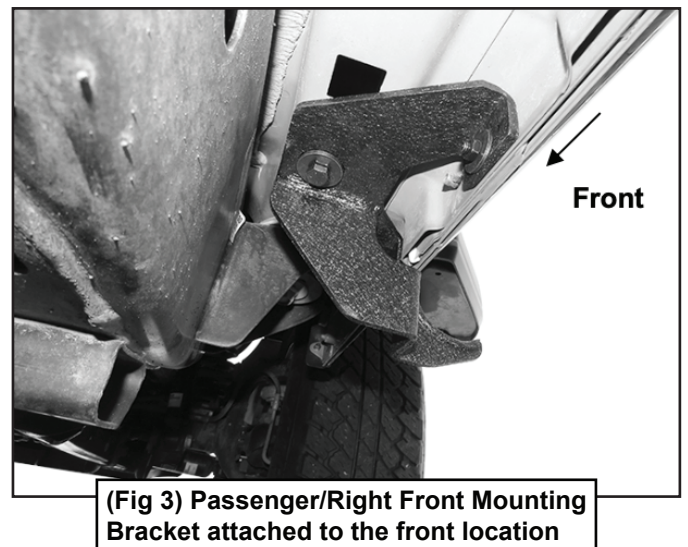

## STEP 3

Next, attach the Mounting Bracket to the pinch weld with (2) 6mm Hex Bolts, (4) 6mm Flat Washers and (2) 6mm Nylon Lock Nuts (Figs 2 & 3). **NOTE:** insert the Hex Bolts in through the outside of the pinch weld. **DO NOT** tighten hardware at this time.



## STEP 4

Move to the center location (Fig 4). Select the Passenger/Right Center Mounting Bracket.

**NOTE:** The Center and Rear Mounting Bracket look similar but each one is unique. The Center Bracket has a larger mounting tab and the Rear Bracket has a smaller mounting tab with a triangle hole in the top (Fig 5). Repeat **STEPS 1-3** to attach the Center Mounting Bracket to the center location (Fig 6).

Passenger/Right Side Installation Pictured

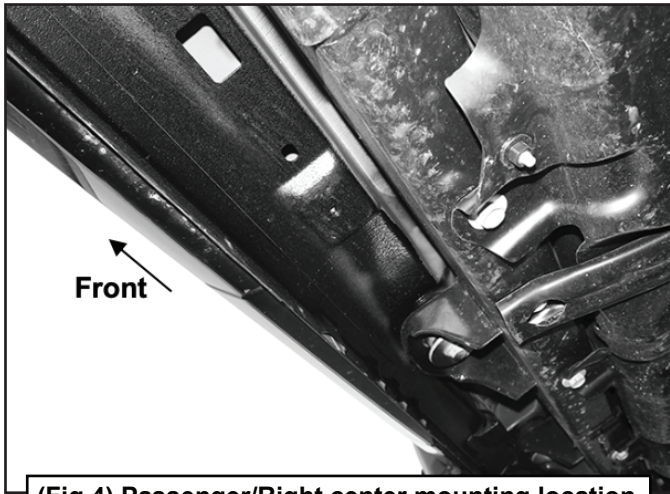

(Fig 4) Passenger/Right center mounting location

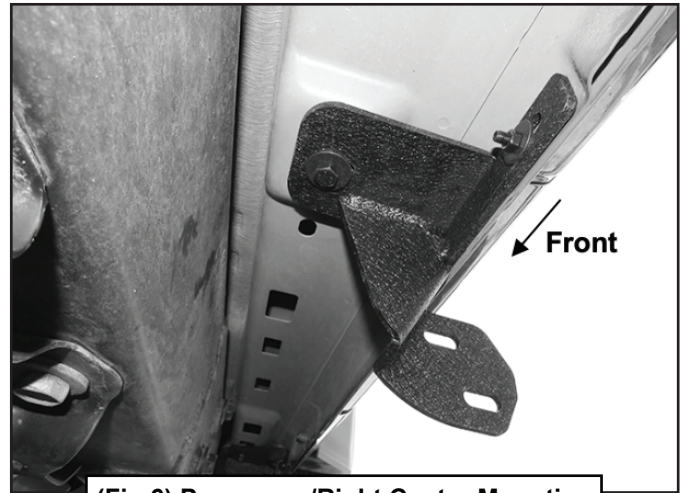

(Fig 6) Passenger/Right Center Mounting Bracket attached to the center location

## STEP 5

Move to the rear location along the body panel (Fig 7). Select the Passenger/Right Rear Mounting Bracket (Fig 5). Repeat **STEPS 1-3** to attach the Rear Bracket (Fig 8).

Passenger/Right Side Installation Pictured

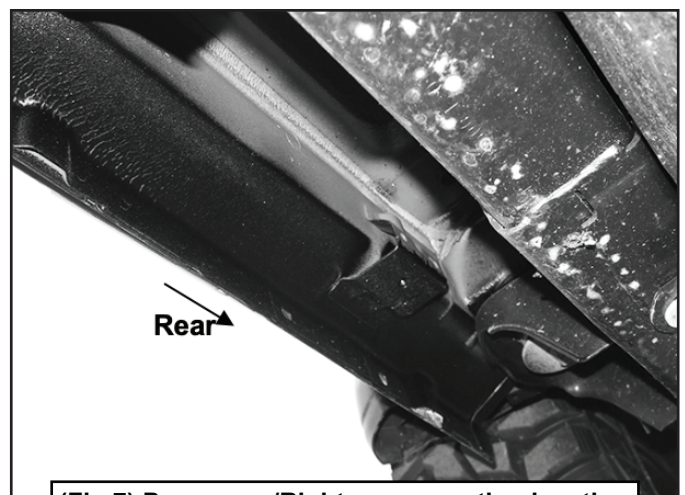

(Fig 7) Passenger/Right rear mounting location

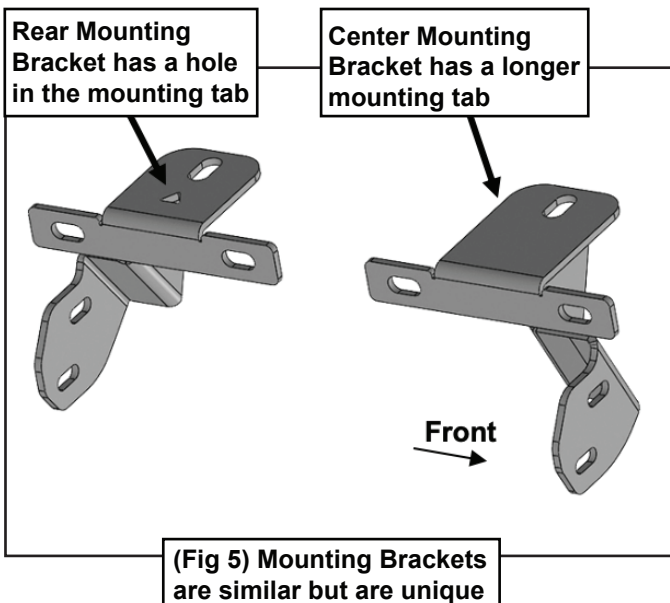



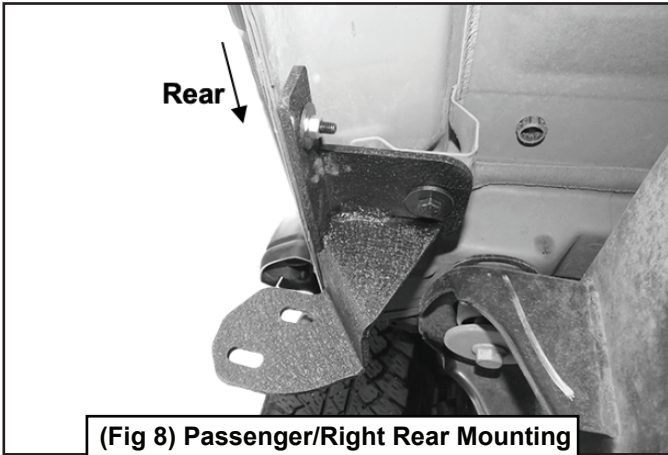

(Fig 8) Passenger/Right Rear Mounting Bracket attached to the rear location

- (2) 10mm Hex Bolts
- (4) 10mm Flat Washers
- (2) 10mm Nylon Lock Nuts

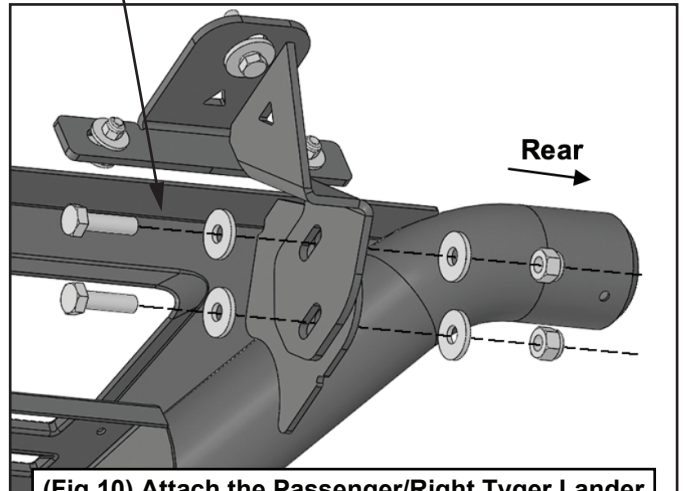

(Fig 10) Attach the Passenger/Right Tyger Lander to the rear face for the Rear Mounting Bracket

## STEP 6

Select the Passenger/Right Tyger Lander. Use the illustration above to determine the correct Side Step. With assistance, hold the Tyger Lander up against the rear faces of the Center Mounting Bracket and the Rear Mounting Bracket.

**IMPORTANT:** DO NOT slide or rotate Tyger Lander on the Front Mounting Bracket cradle, or damage to the finish may result. Attach the Tyger Lander to the rear faces of the Center and Rear Mounting Brackets with (4) 10mm Hex Bolts, (8) 10mm Flat Washers and (4) 10mm Nylon Lock Nuts (Figs 9-10). DO NOT tighten hardware at this time.

### Passenger/Right Side Installation Pictured

- (2) 10mm Hex Bolts
- (4) 10mm Flat Washers
- (2) 10mm Nylon Lock Nuts

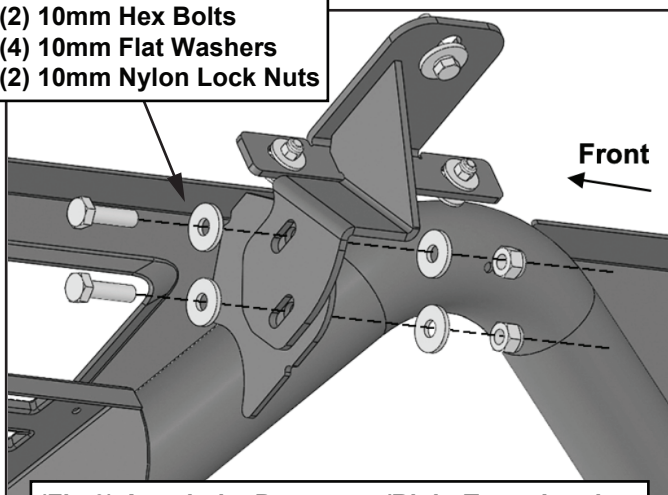

(Fig 9) Attach the Passenger/Right Tyger Lander to the rear face for the Center Mounting Bracket

## STEP 7

Attach the Tyger Lander to the Front Mounting Bracket with (2) 8mm Combo Bolts (Figs 11 & 12). DO NOT tighten hardware at this time.

### Passenger/Right Side Installation Pictured

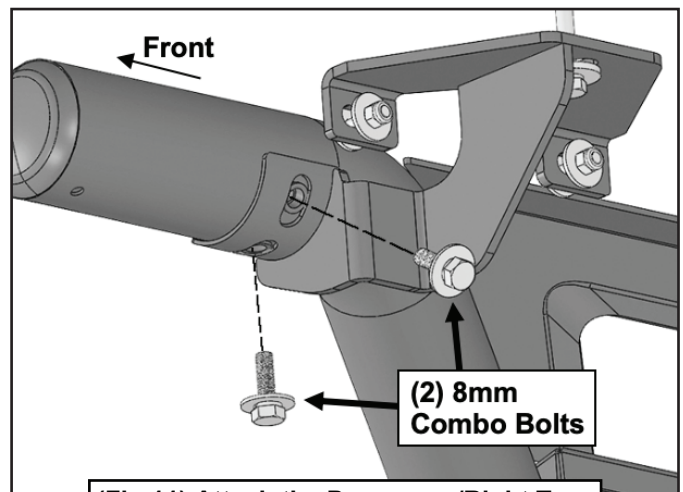

(Fig 11) Attach the Passenger/Right Tyger Lander to the Front Mounting Bracket

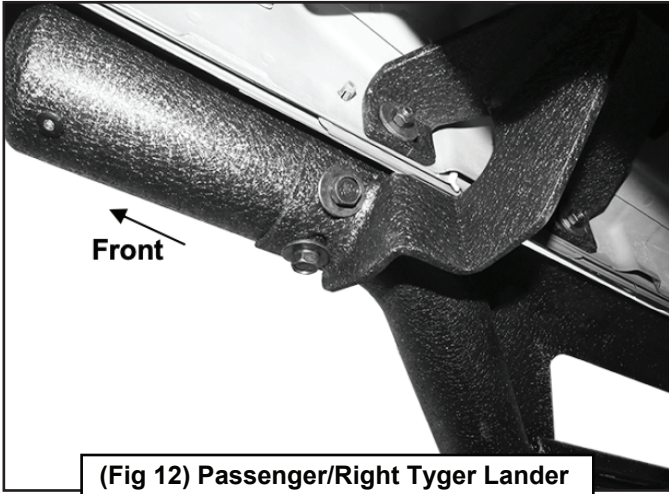

(Fig 12) Passenger/Right Tyger Lander attached to the Front Mounting Bracket

## STEP 8

Level and adjust the Tyger Lander and tighten all hardware.

## STEP 9

Repeat **STEPS 1-8** to attach the Driver/Left Tyger Lander.

## STEP 10

Do periodic inspections to the installation to make sure that all hardware is secure and tight.