



TYGER LANDER®

TG-LD2J62398

BEFORE INSTALLATION

READ INSTRUCTIONS CAREFULLY BEFORE STARTING INSTALLATION. REMOVE CONTENTS FROM BOX AND VERIFY ALL PARTS ARE PRESENT. FAILURE TO IDENTIFY DAMAGE BEFORE INSTALLATION COULD LEAD TO A REJECTION OF ANY CLAIM. IF MISSING PARTS OR ANY DAMAGE FOUND, PLEASE TAKE A PICTURE FOR THE CLAIM PURPOSE.

TORQUE VALUES

Fastener Size	Class 8.8 Torque (ft-lbs)	Class 10.9 Torque (ft-lbs)
6mm	6-7	6-7
8mm	15-16	22-23
10mm	31-32	44-45
12mm	54-55	78-79
14mm	87-88	125-126

Parts List

- x1 Driver/Left Tyger Lander
- x1 Passenger/Right Tyger Lander
- x1 Driver/Left Front Mounting Bracket
- x1 Passenger/Right Front Mounting Bracket
- x1 Driver/Left Center Mounting Bracket
- x1 Passenger/Right Center Mounting Bracket
- x1 Driver/Left Rear Mounting Bracket
- x1 Passenger/Right Rear Mounting Bracket
- x8 10-1.5mm x 35mm Hex Bolts
- x16 10mm x 27mm OD x 3mm Flat Washers
- x8 10mm Nylon Lock Nuts
- x6 8mm Nut Plates
- x6 8-1.25mm x 35mm Hex Bolts
- x4 8-1.25mm x 25mm Combo Bolts
- x6 8mm Lock Washers
- x6 8mm x 28mm OD x 3mm Flat Washers
- x12 6-1.0mm x 25mm Hex Bolts
- x24 6mm x 22mm OD x 2mm Flat Washers
- x12 6mm Nylon Lock Nuts

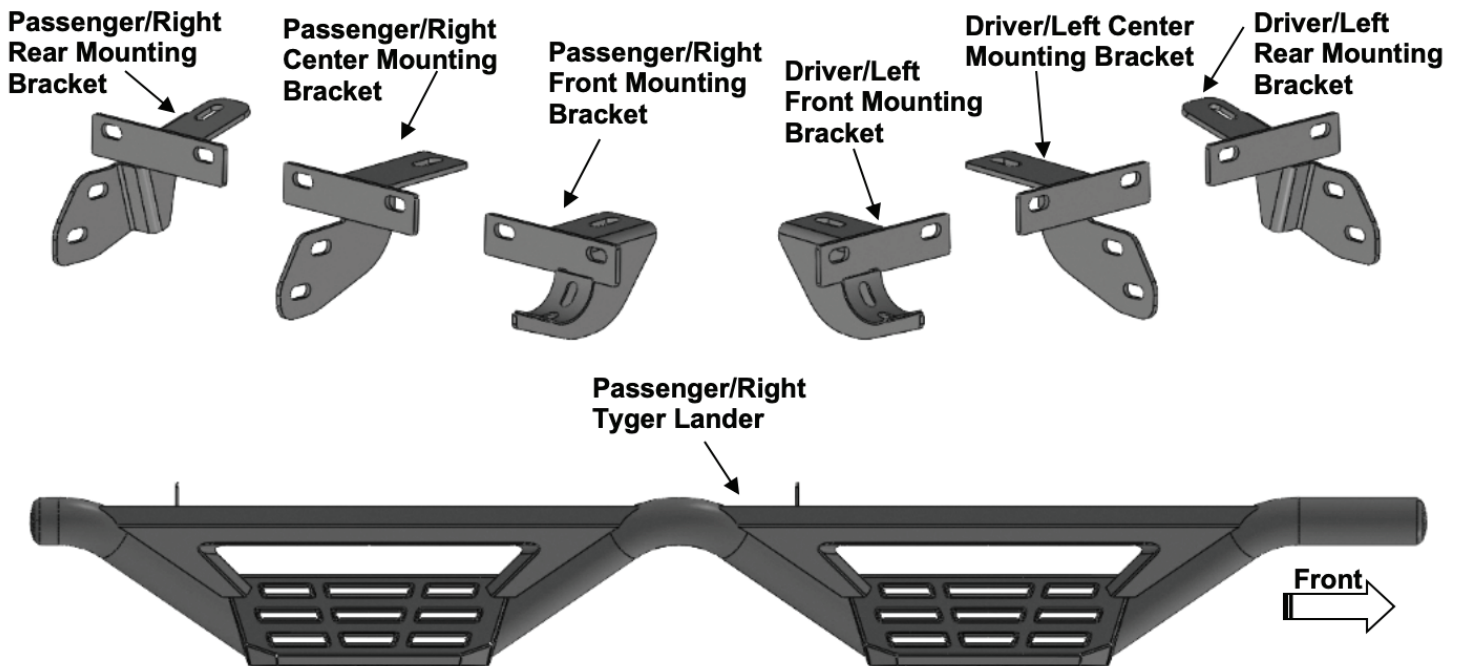



STEP 1

REMOVE CONTENTS FROM BOX. VERIFY ALL PARTS ARE PRESENT. READ INSTRUCTIONS CAREFULLY. FACTORY INSTALLED OR AFTERMARKET PRODUCT MUST BE REMOVED.

STEP 2

Start installation toward the front of the Passenger/Right side of the vehicle (Fig 1).

Passenger/Right Side Installation Pictured

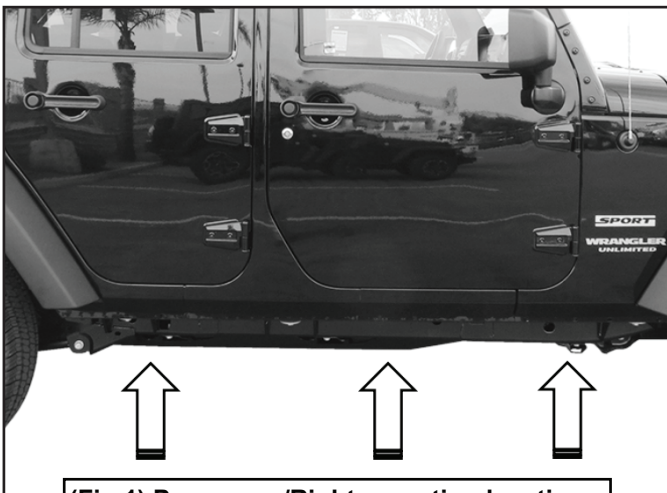

(Fig 1) Passenger/Right mounting locations

STEP 3

Determine if vehicle is equipped with threaded mounting inserts

Vehicles without threaded inserts:

a. Insert (1) 10mm Nut Plate into the large square opening in the floor panel. Line up the threaded nut with the hole in between the pair of holes on the pinch weld (Figs 2A & 2B).

Passenger/Right Side Installation Pictured

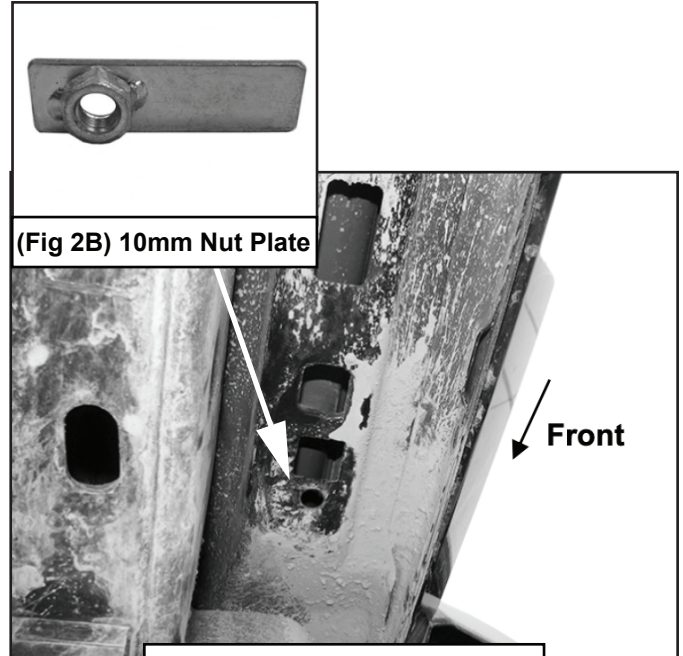

(Fig 2B) 10mm Nut Plate

(Fig 2A) Passenger/Right front mounting location (Models without threaded insert shown)

b. Select the Passenger/Right Front Mounting Bracket.

c. Attach the Bracket to the Nut Plate with (1) 8mm Hex Bolt, (1) 8mm Lock Washer and (1) 8mm Flat Washer (Fig 3). DO NOT tighten hardware.

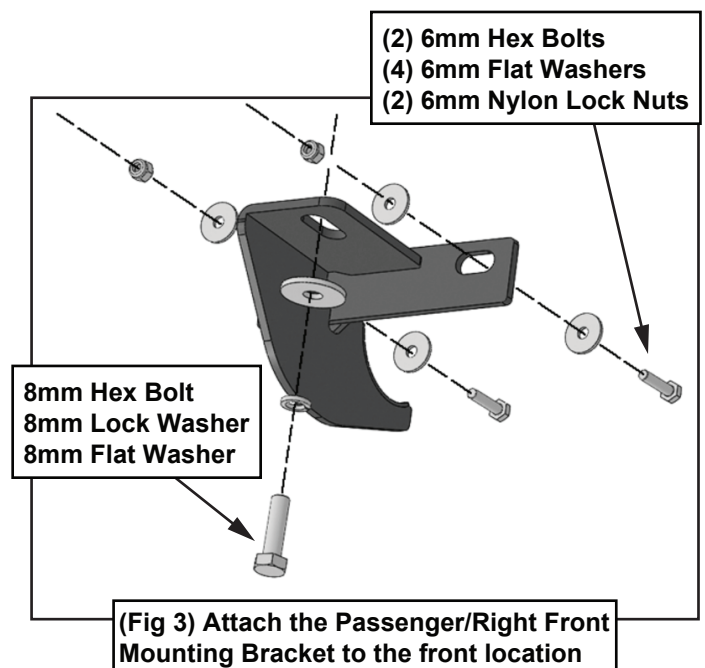

(Fig 3) Attach the Passenger/Right Front Mounting Bracket to the front location



d. Attach the Mounting Bracket to the pinch weld with (2) 6mm Hex Bolts, (4) 6mm Flat Washers and (2) 6mm Nylon Lock Nuts (Fig 3). DO NOT tighten hardware.

Vehicles with factory threaded hole in floor panel:

- a. Locate the front, center and rear mounting locations (Fig 1).
- b. Select the Passenger/Right Front Mounting Bracket.
- c. Attach the Bracket to the front mounting location with (1) 8mm Hex Bolt, (1) 8mm Lock Washer and (1) 8mm Flat Washer (Fig 3). DO NOT tighten hardware.
- d. Attach the Mounting Bracket to the pinch weld with (2) 6mm Hex Bolts, (4) 6mm Flat Washers and (2) 6mm Nylon Lock Nuts, (Fig 3). DO NOT tighten hardware.

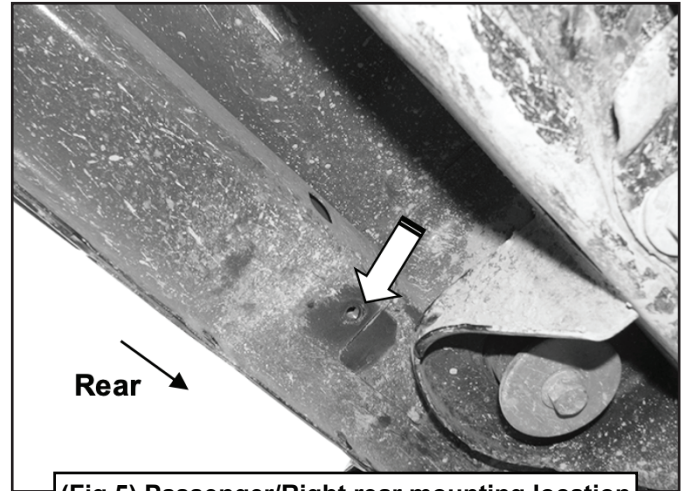

(Fig 5) Passenger/Right rear mounting location (Model with threaded inset shown)

STEP 4

Repeat **STEP 3** to attach the Brackets to the center and rear locations (Figs 4A, 4B & 5). DO NOT tighten hardware.

Passenger/Right Side Installation Pictured

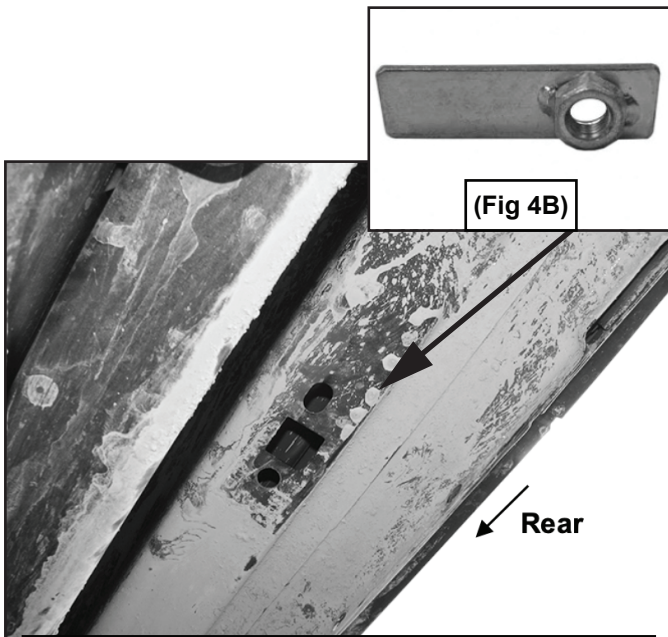

(Fig 4A) Passenger/Right center mounting location (Model without threaded inset shown)

STEP 5

5. Select the Passenger/Right Tyger Lander. Attach the Tyger Lander to the rear faces of the Center and Rear Mounting Brackets with (4) 10mm Hex Bolts, (8) 10mm Flat Washers and (4) 10mm Nylon Lock Nuts (Fig 6).

IMPORTANT: DO NOT slide or rotate Sidebar on the Front Mounting Bracket cradle, or damage to the finish may result.

**(2) 10mm Hex Bolts
(4) 10mm Flat Washers
(2) 10mm Nylon Lock Nuts**

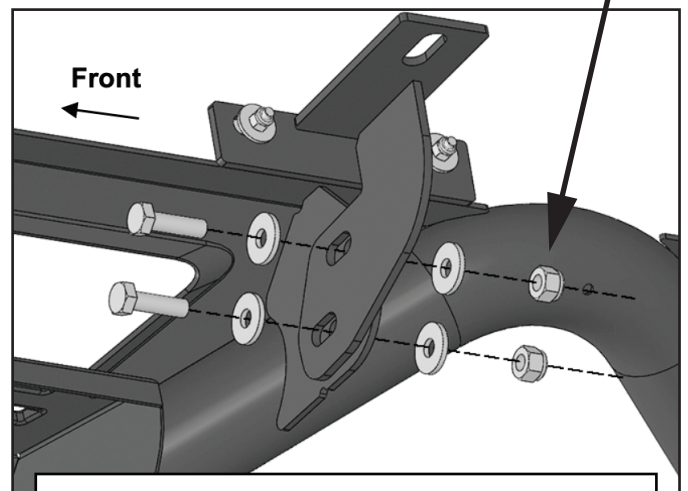

(Fig 6) Attach the Passenger/Right Tyger Lander to the Center and Rear Mounting Brackets



STEP 6

Attach the Tyger Lander to the Front Mounting bracket with (2) 8mm Combo Bolts (Fig 7). DO NOT tighten hardware.

Passenger/Right Side Installation Pictured

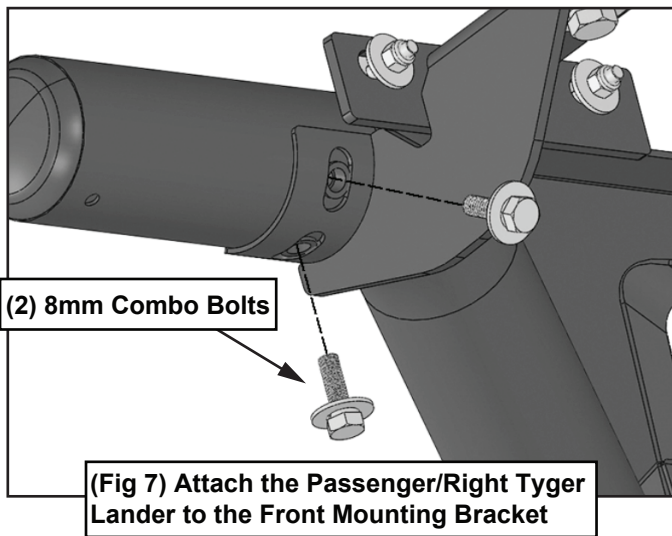

STEP 7

Level and adjust the Tyger Lander and tighten all hardware.

STEP 8

Repeat **STEPS 1-7** to attach the Driver/Left Tyger Lander.

STEP 9

Do periodic inspections to the installation to make sure that all hardware is secure and tight.