



## STAR ARMOR®

TG-JA2J2359B

### BEFORE INSTALLATION

READ INSTRUCTIONS CAREFULLY BEFORE STARTING INSTALLATION. REMOVE CONTENTS FROM BOX AND VERIFY ALL PARTS ARE PRESENT. FAILURE TO IDENTIFY DAMAGE BEFORE INSTALLATION COULD LEAD TO A REJECTION OF ANY CLAIM. IF MISSING PARTS OR ANY DAMAGE FOUND, PLEASE TAKE A PICTURE FOR THE CLAIM PURPOSE.

### TORQUE VALUES

Fastener Size	Class 8.8 Torque (ft-lbs)	Class 10.9 Torque (ft-lbs)
6mm	6-7	6-7
8mm	15-16	22-23
10mm	31-32	44-45
12mm	54-55	78-79
14mm	87-88	125-126

### Parts List

- x1 Driver/Left Tyger Armor
- x1 Passenger/Right Tyger Armor
- x6 8-1.25mm x 35mm Hex Bolts
- x6 8mm Lock Washers
- x6 8mm x 28mm x 3mm Flat Washers
- x12 6-1.0mm x 25mm Hex Bolts
- x24 6mm x 22mm x 2mm Flat Washers
- x12 6mm Nylon Lock Nuts

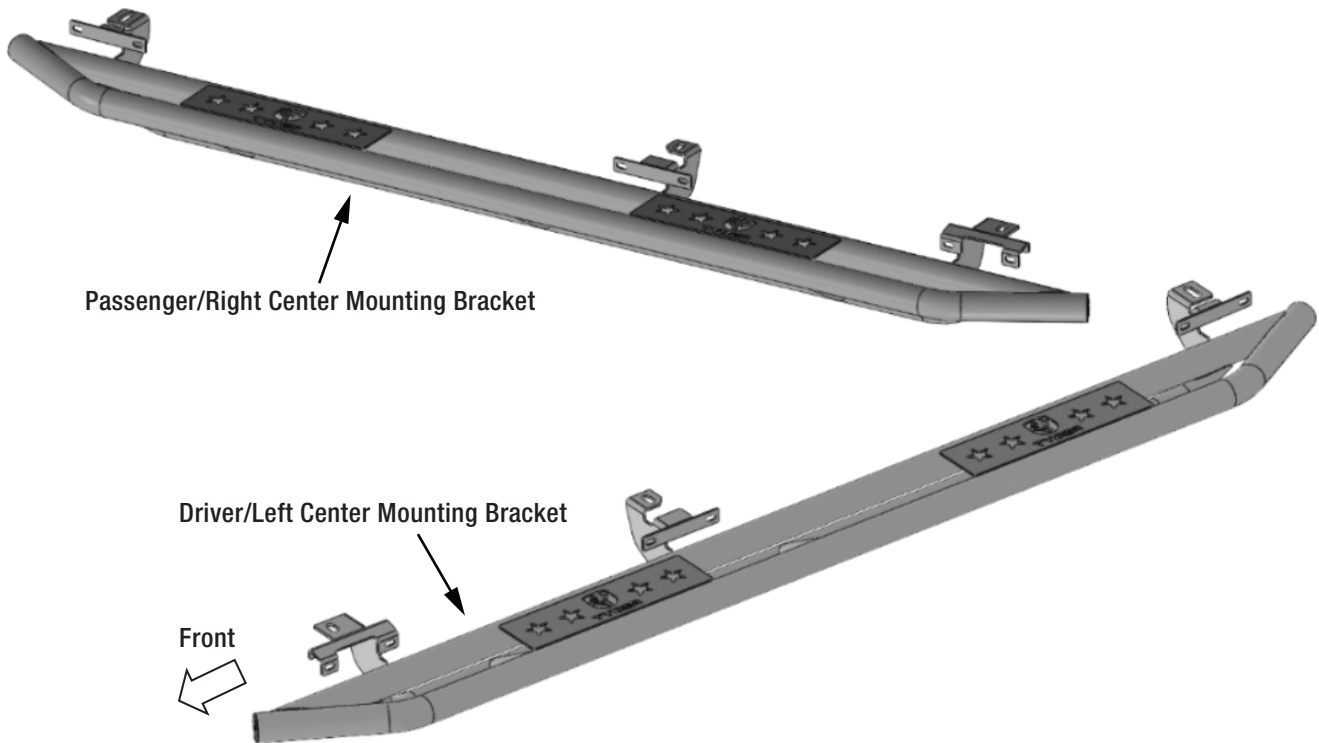

Passenger/Right Center Mounting Bracket

Driver/Left Center Mounting Bracket

Front



## STEP 1

REMOVE CONTENTS FROM BOX. VERIFY ALL PARTS ARE PRESENT. READ INSTRUCTIONS CAREFULLY BEFORE STARTING INSTALLATION. SIDE STEPS OR RUNNING BOARDS MUST BE REMOVED BEFORE INSTALLATION.

## STEP 2

Start installation on the Passenger/Right front of the of the vehicle. Find the front threaded insert located in between the first pair of holes along the pinch weld, (Figure 2). Installation will use the **1st, 2nd** and **4th** mounting locations, (Figure 1).

Passenger/Right Side Installation Pictured

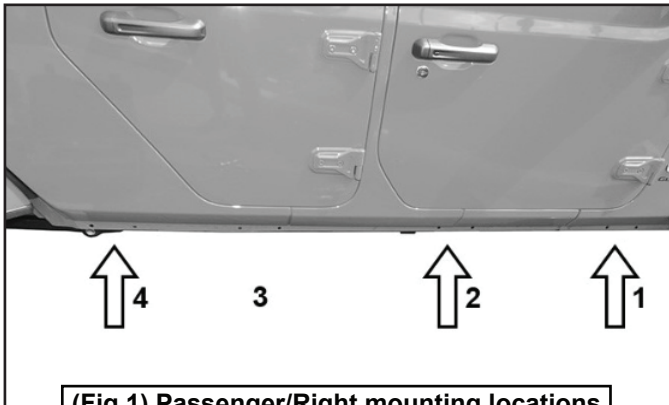

(Fig 1) Passenger/Right mounting locations



(Fig 2) Passenger/Right front mounting location with threaded insert

## STEP 3

Select the Passenger/Right Tyger Armor. With assistance, attach the Tyger Armor to the the **1st, 2nd** and **4th** location using (3) 8mm x 35mm Hex Bolts, (3) 8mm Lock Washers and (3) 8mm Flat Washers, (Figures 2—5). DO NOT tighten hardware.

Passenger/Right Side Installation Pictured

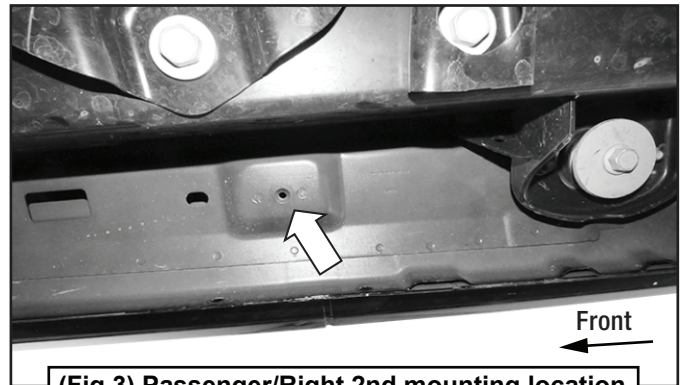

(Fig 3) Passenger/Right 2nd mounting location

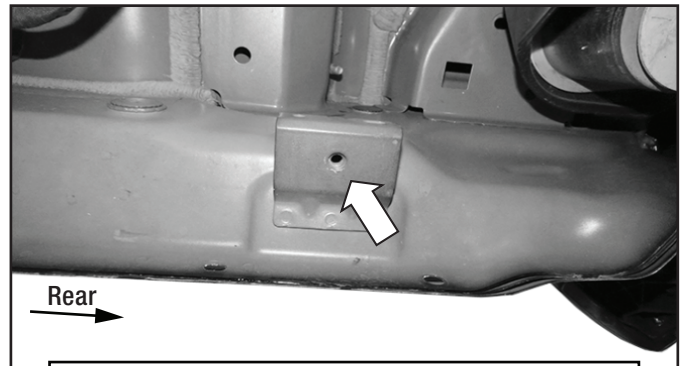

(Fig 4) Passenger/Right rear mounting location

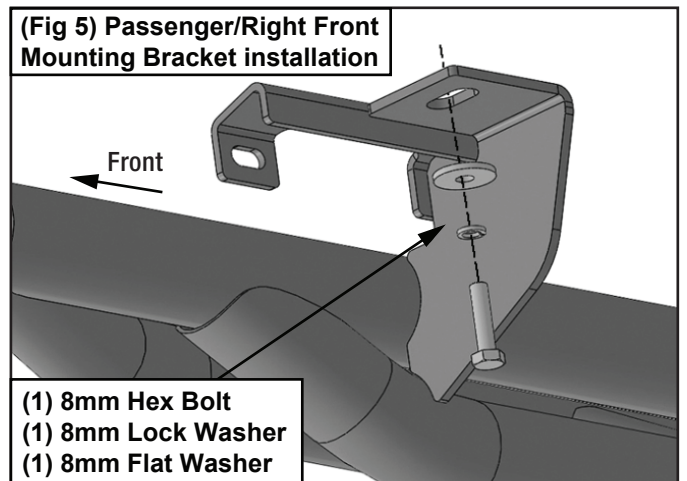

(Fig 5) Passenger/Right Front Mounting Bracket installation

- (1) 8mm Hex Bolt
- (1) 8mm Lock Washer
- (1) 8mm Flat Washer



## STEP 4

Attach the Tyger Armor to the pinch weld using (6) 6mm Hex Bolts, (12) 6mm Flat Washers and (6) 6mm Nylon Lock Nuts, (Figure 6).

**NOTE:** Insert bolts from the outside of the pinch weld and through the support tab. DO NOT tighten hardware.

Passenger/Right Side Installation Pictured

(2) 6mm Hex Bolts  
(4) 6mm Flat Washers  
(2) 6mm Nylon Lock Nuts

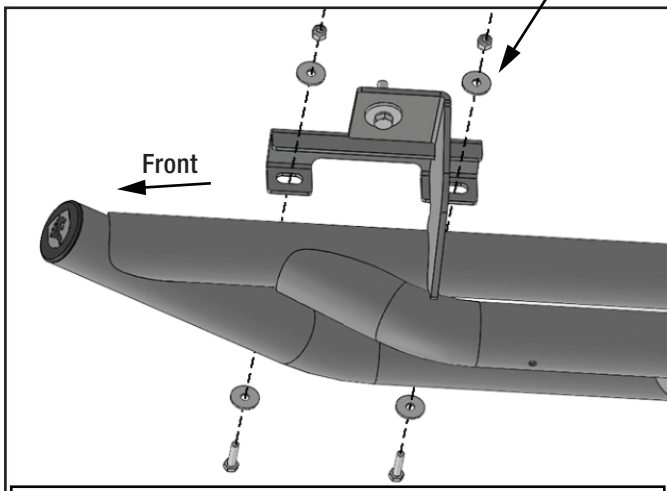

(Fig 6) Attach Support Bracket to back of pinch weld

## STEP 5

Level and adjust the Tyger Armor and tighten all hardware.

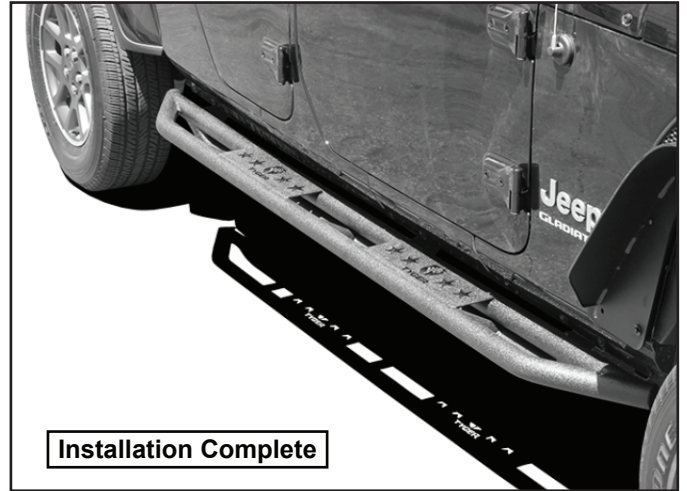

## STEP 6

Repeat **STEPS 1—5** for Driver/Left Tyger Armor installation.

## STEP 7

Do periodic inspections to the installation to make sure that all hardware is secure and tight.