



TYGER®

HITCH KIT

FOR:
2003-2018 RAM 1500
2003-2013 RAM 2500/3500

BEFORE INSTALLATION

READ INSTRUCTIONS CAREFULLY BEFORE STARTING INSTALLATION. REMOVE CONTENTS FROM BOX AND VERIFY ALL PARTS ARE PRESENT. FAILURE TO IDENTIFY DAMAGE BEFORE INSTALLATION COULD LEAD TO A REJECTION OF ANY CLAIM. IF MISSING PARTS OR ANY DAMAGE FOUND.

CAUTION

PERIODICALLY CHECK THIS RECEIVER HITCH TO ENSURE THAT ALL FASTENERS ARE TIGHT AND THAT ALL STRUCTURAL COMPONENTS ARE SOUND. NEVER EXCEED THE CAPACITY RATINGS SHOWN ON THE RECEIVER HITCH OR THE TOW VEHICLE. SEE YOUR VEHICLE'S OWNERS GUIDE FOR TOWING GUIDELINES.

FAILURE TO FOLLOW THESE GUIDELINES WILL VOID THE TYGER AUTO WARRANTY AND MAY RESULT IN PERSONAL INJURY AND/OR INJURY TO OTHERS AS WELL AS VEHICLE DAMAGE.

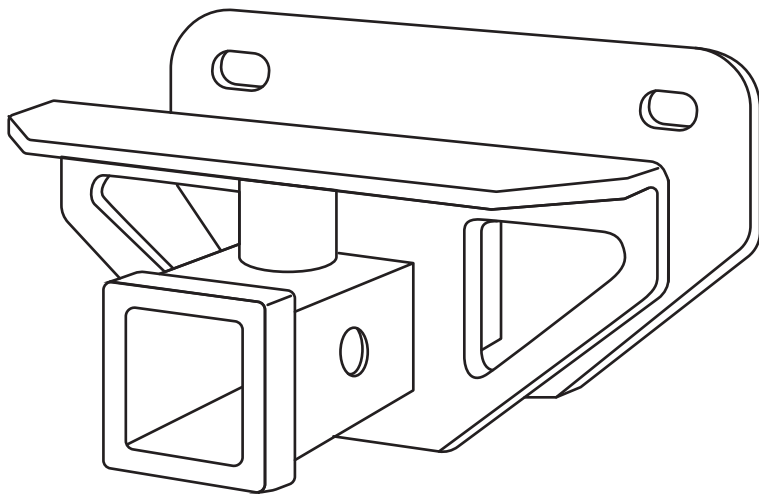

TG-HC3D002B

NOTE: NO DRILLING REQUIRED. Remove contents from box, verify if all parts listed are present and free from damage. Carefully read and understand all instructions before attempting installation.

Parts List

- x2 M14 BOLT PLATE
- x2 M14 HEX NUT
- x2 M14 FLAT WASHER
- x2 M14 FISHWIRE
- x2 M14 LOCK WASHER
- x1 FLAT HEAD SOCKET CAP SCREW, ZP

Tools Needed

- 21MM SOCKET
- 12MM HEX BIT SOCKET
- RATCHET
- TORQUE WRENCH

GROSS LOAD CAPACITY WHEN USED AS A WEIGHT CARRYING HITCH:

6,000 LBS. Trailer weight & 600 LBS. Tongue weight.

GROSS LOAD CAPACITY WHEN USED AS A WEIGHT DISTRIBUTION HITCH:

6,000 LBS. Trailer weight & 600 LBS. Tongue weight.



TYGER[®]

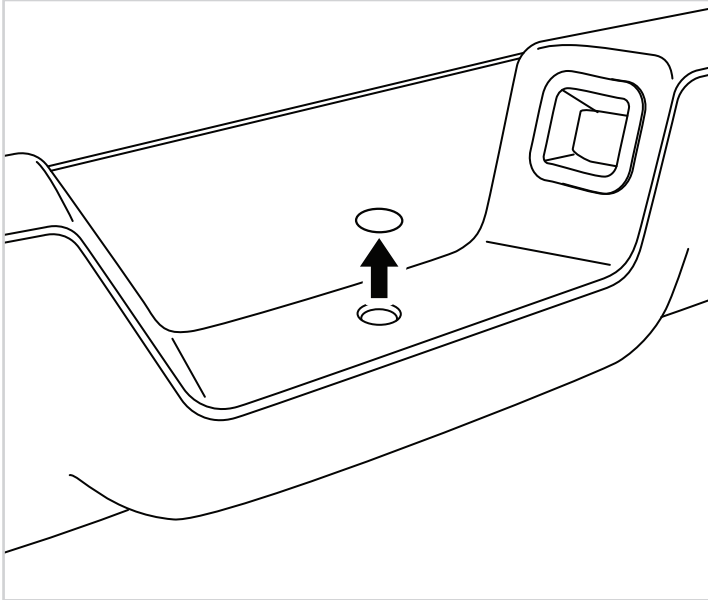

STEP 1: Remove existing trailer ball hole cap on center of bumper and set aside.

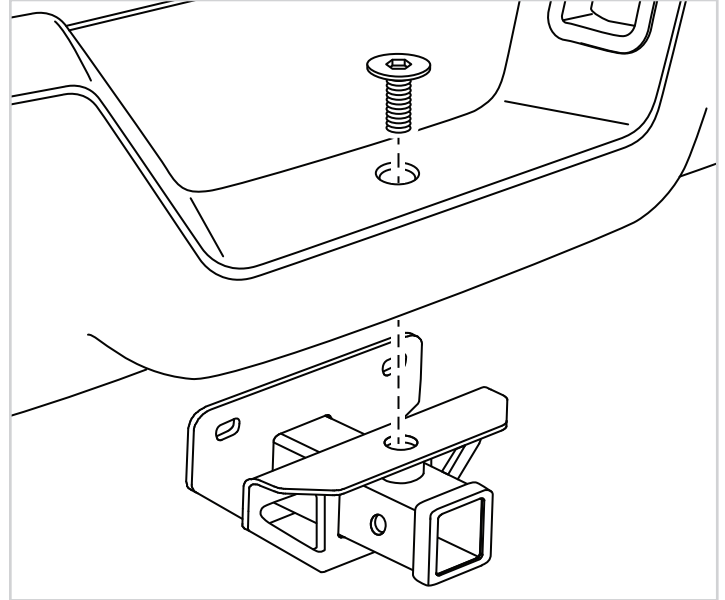

STEP 2: Raise the hitch into position and secure with flat head socket cap screw through the bumper and bumper support into the hitch.

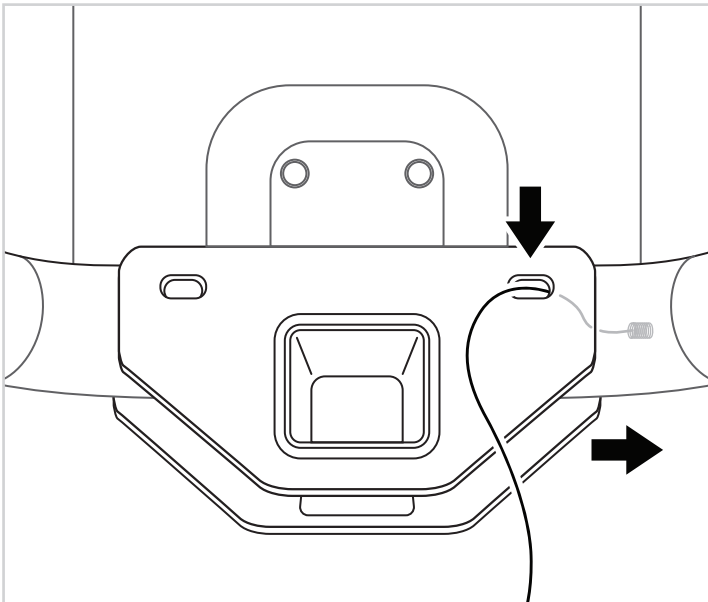

STEP 3: Insert coiled end of the fishwire tool through hitch mounting hole in vehicle frame tube.

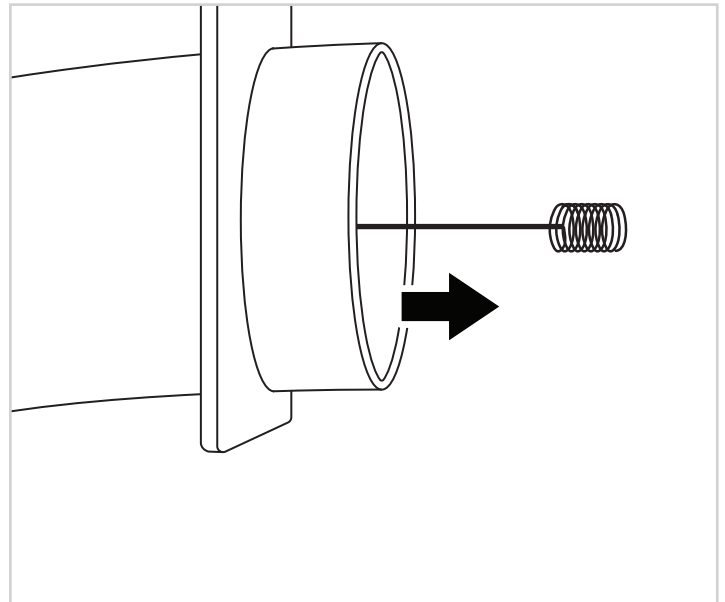

STEP 4: Pull coiled end of the fishwire out of the frame tube hole.



TYGER[®]

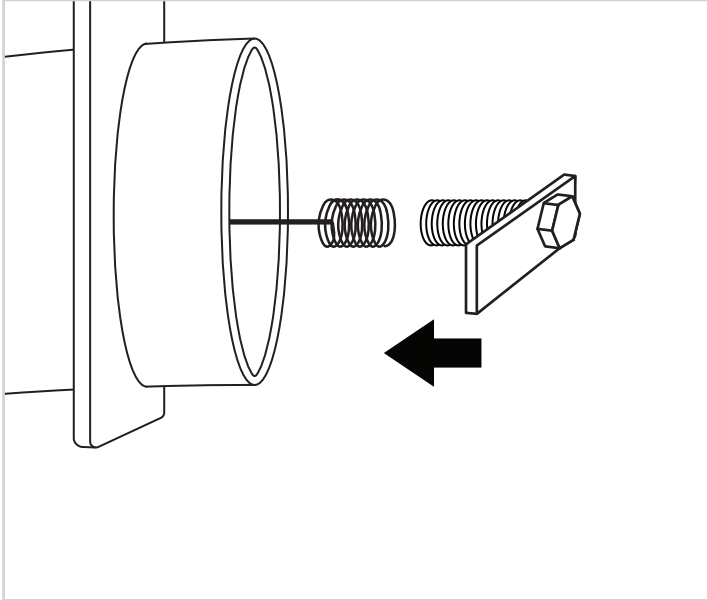

STEP 5: Attach bolt plate onto fishwire then insert into frame tube.

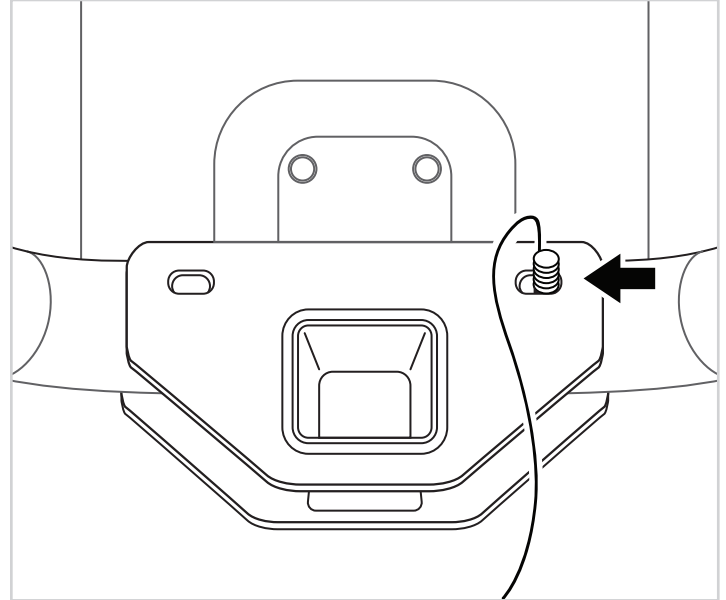

STEP 6: Pull bolt plate out in hitch mounting hole through frame tube. (Then repeat STEP 3 - 6 for the other bolt plate.)

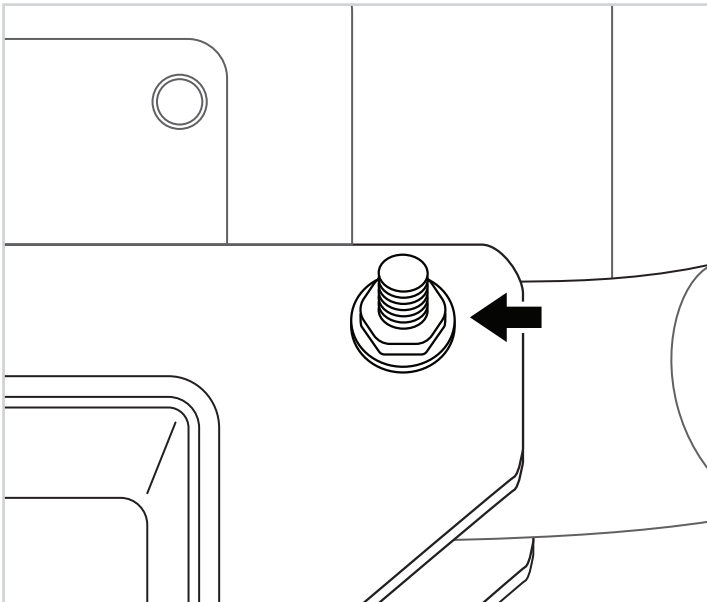

STEP 7: Secure the two bolt plates with washers and nuts. Torque hardware to 100 lb-ft.

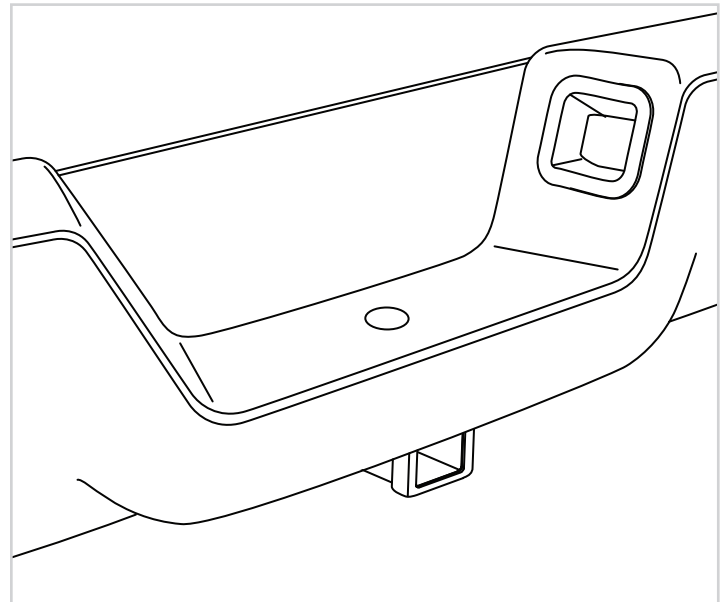

STEP 8: Torque the flat head socket cap screw to 250 lb-ft. Installation complete.