

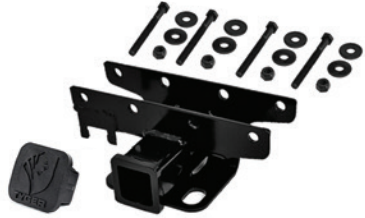

# TYGER<sup>®</sup>



**TG-HC2J001B:**  
**FOR 2007-UP Wrangler JK 2DR & 4DR**

## Parts List

- x1** Receiver Hitch
- x8** Flat Washers
- x4** Mounting Bolts
- x1** Hitch Cover
- x4** Nylock Nuts

## Tow Rating

2 DR JK (Up to 2000lbs)

4 DR JK (Up to 3500lbs)

## Before Installation

If your vehicle is equipped with a tow hook, it must first be removed from the vehicle. There are 3 bolts holding the rear tow hook to the rear cross member. These must be removed, and the tow hook slid down off the cross member.

## Warning

- Do not exceed the above-stated tow rating for each model or it will void warranty.
- The Receiver Hitch installs very close to the muffler, which can get very hot. Please ensure that the vehicle is cool before attempting to install.
- If you are unclear with the installation, please seek professional advice to avoid damages.

### STEP 1

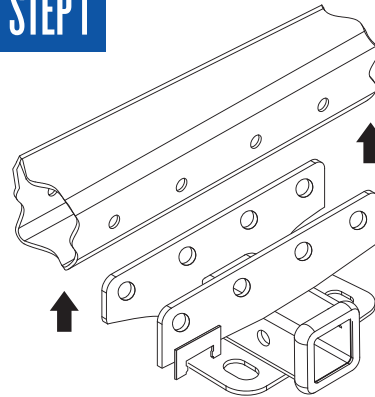

Slide the receiver over the rear crossmember, taking care to align the 4 holes in the receiver with the 4 holes in the cross member. Once in place, insert left or right most bolt with flat washer into the back side of the hitch and through the cross member. Place the nylock nut and flat washer on to the bolt. Secure but do not tighten.

### STEP 2

Once all 4 bolts and nylocks have been started, tighten them. The nuts will need to be held in place with an open end wrench. Torque all 1/2" bolts to 110 lb-f. (For Rubicon X & 10th Anniversary models, use factory bolts instead of supplied bolts.)

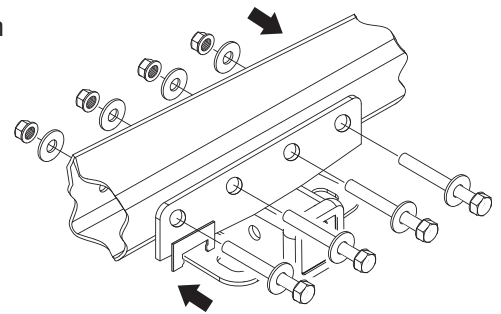

### STEP 3

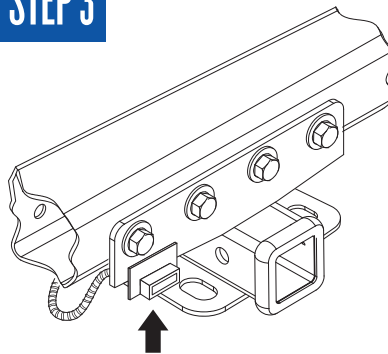

Insert the trailer wiring, if equipped, into the trailer wiring mounting tab on the receiver as shown. Installation is now complete.