



# TYGER®

## TYGER GUARD™

### BEFORE INSTALLATION

READ INSTRUCTIONS CAREFULLY BEFORE STARTING INSTALLATION. REMOVE CONTENTS FROM BOX AND VERIFY ALL PARTS ARE PRESENT. ASSISTANCE IS RECOMMENDED. FAILURE TO IDENTIFY DAMAGE BEFORE INSTALLATION COULD LEAD TO A REJECTION OF ANY CLAIM. IF ANY DAMAGE FOUND, PLEASE TAKE A PICTURE FOR THE CLAIM PURPOSE.

### WARNING

TEXTURED COATED FINISHES SHOULD BE CLEANED WITH A MILD SOAP ON A DAMP SPONGE. DO NOT APPLY POLISH OR WAX THAT REQUIRES TO BE REMOVED BY MEANS OF BUFFING. THIS TYPE OF WAX IS COMMONLY USED AT CAR WASH FACILITIES.

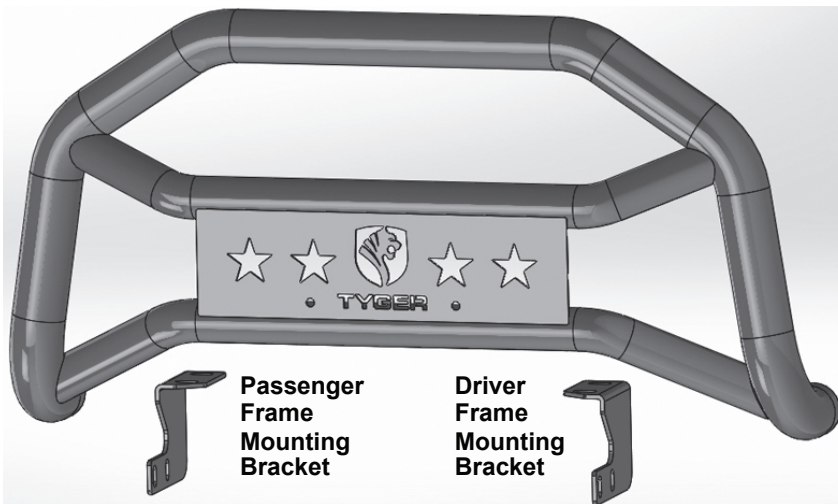

Tube  
Mounting  
Bracket

Tube  
Mounting  
Bracket



**TG-GD6T60078**

**NOTE:** Installation may interfere with front mounted sensors. Not recommended for vehicles with optional "active" laser guided cruise control systems.

### Parts List

- x1** Tyger Guard
- x2** Tube Mounting Brackets (left or right)
- x1** Driver/Left Frame Mounting Bracket
- x1** Passenger/Right Frame Mounting Bracket
- x4** 8-1.25mm x 35mm Hex Bolts
- x4** 8mm Lock Washers
- x4** 8mm x 22mm OD x 2mm Flat Washers
- x4** 10-1.5mm x 35mm Hex Bolts
- x4** 10-1.5mm x 110mm Hex Bolts
- x8** 10mm x 27mm OD x 3mm Flat Washers
- x8** 10mm x 34mm OD x 3mm Flat Washers
- x8** 10-1.5mm Nylon Lock Nuts
- x2** 6-1.0mm x 20mm Combo Bolts (license plate)
- x1** 4mm Wrench



# TYGER<sup>®</sup>

## STEP 1

Start installation at the driver side, front of the vehicle. Remove the factory skip plate if equipped. Starting behind the front bumper on the driver side, locate the section of rectangular frame channel attached to the back of the bumper, (Fig 1). Insert (2) 10-1.5mm x 110mm Hex Bolts with (2) 10mm x 34mm Large Flat Washers into and down through the (2) vertical holes in the top of the bumper bracket, (Figs 2-3). Select the driver side Frame Mounting Bracket. Line up the (2) slots in the Bracket with the (2) 10mm Hex Bolts. Secure the Bracket to the bottom of the bumper bracket with (2) 10mm x 34mm Large Flat Washers and (2) 10mm Nylon Lock Nuts, (Fig 4). Do not tighten hardware.

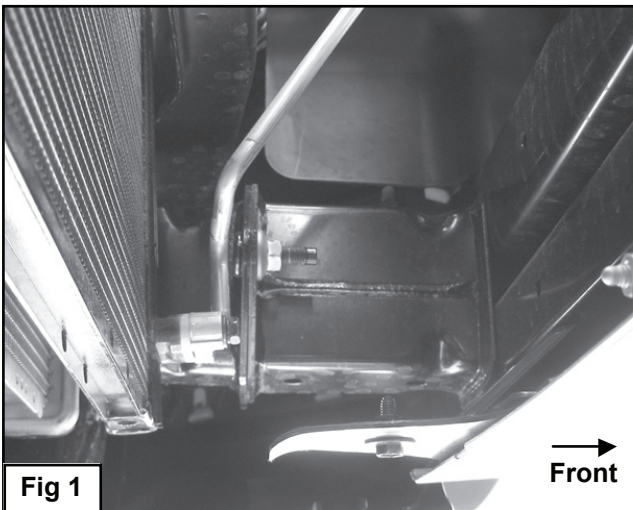

Fig 1

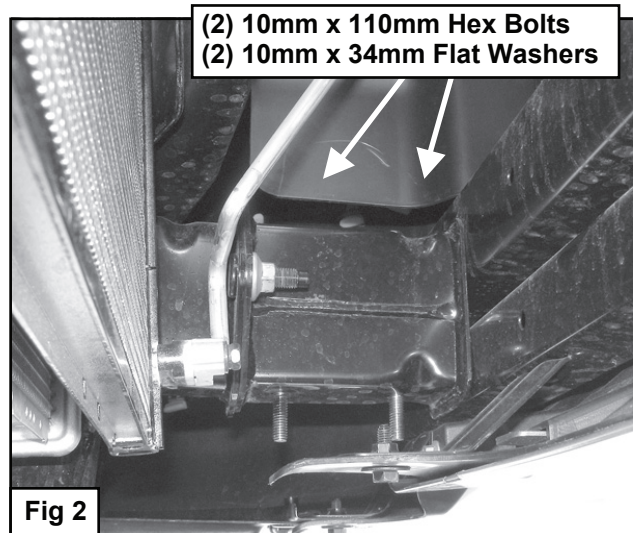

Fig 2

## STEP 2

Repeat Step 1 for the passenger side Frame Mounting Bracket installation.

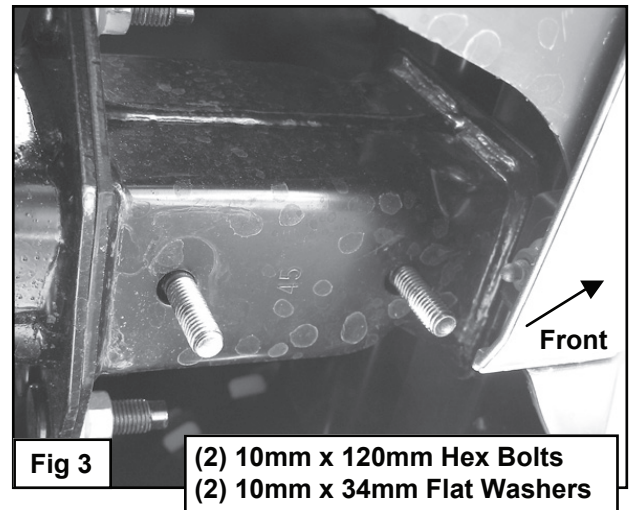
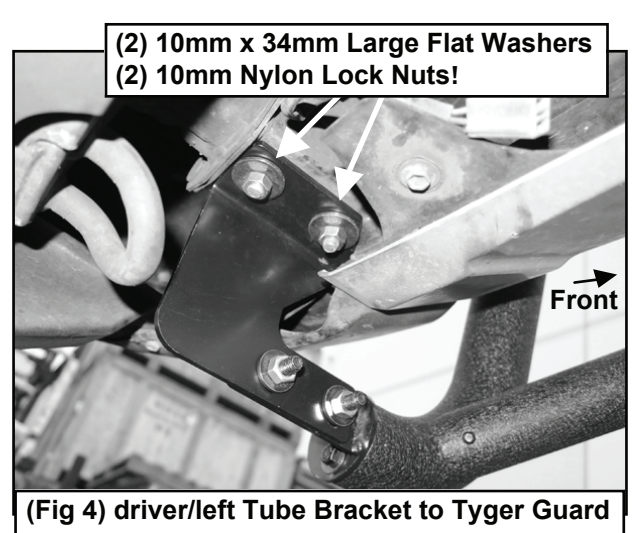

Fig 3



(Fig 4) driver/left Tube Bracket to Tyger Guard



# TYGER<sup>®</sup>

## STEP 3

Carefully unwrap the Tyger Guard. Select (1) Tube Mounting Bracket. Attach the Bracket to the end of the Tyger Guard with (2) 8-1.25mm Hex Bolts, (2) 8mm Lock Washers, (2) 8mm Flat Washers, (Fig 5). Do not tighten hardware at this time.

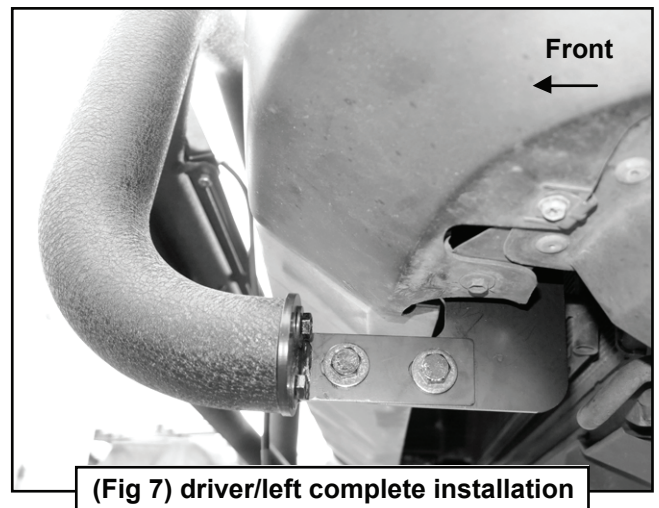
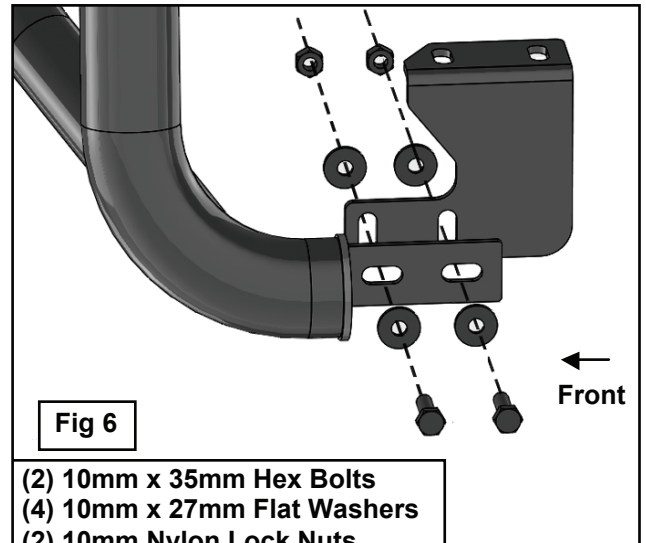
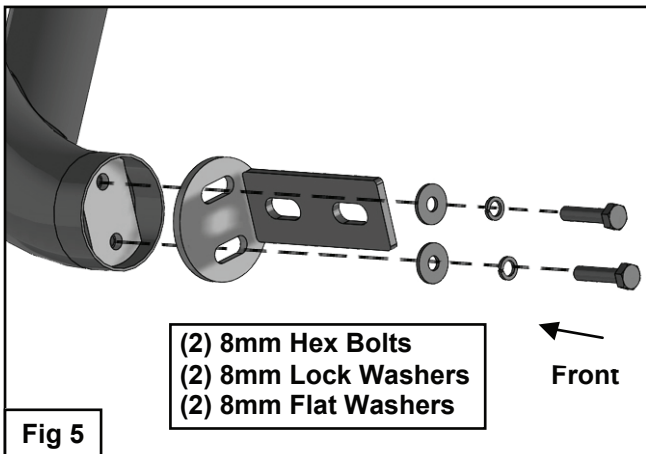

## STEP 4

With assistance, line up the Tube Mounting Brackets on the Tyger Guard with the outside of the Frame Brackets. Attach the Tyger Guard to the Frame Brackets with the included (4) 10-1.5mm x 35mm Hex Bolts, (8) 10mm x 27mm Flat Washers and (4) 10-1.5mm Nylon Lock Nuts, (Figs 6-7). Do not tighten hardware.

## STEP 5

Repeat Step 4 for the passenger side Frame Mounting Bracket installation.

## STEP 6

Level and adjust the Tyger Guard properly and tighten all hardware. Do periodic inspections to the installation to make sure that all hardware is secure and tight.

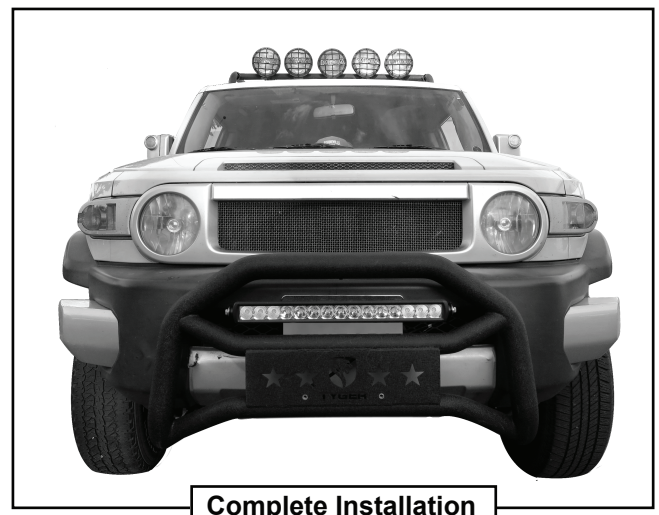

Tyger provides the best in grille guards and bull bars equipment.