



TYGER®

TYGER GUARD™

TG-GD6T60028

BEFORE INSTALLATION

READ INSTRUCTIONS CAREFULLY BEFORE STARTING INSTALLATION. REMOVE CONTENTS FROM BOX AND VERIFY ALL PARTS ARE PRESENT. ASSISTANCE IS RECOMMENDED. FAILURE TO IDENTIFY DAMAGE BEFORE INSTALLATION COULD LEAD TO A REJECTION OF ANY CLAIM. IF ANY DAMAGE FOUND, PLEASE TAKE A PICTURE FOR THE CLAIM PURPOSE.

WARNING

TEXTURED COATED FINISHES SHOULD BE CLEANED WITH A MILD SOAP ON A DAMP SPONGE. DO NOT APPLY POLISH OR WAX THAT REQUIRES TO BE REMOVED BY MEANS OF BUFFING. THIS TYPE OF WAX IS COMMONLY USED AT CAR WASH FACILITIES.

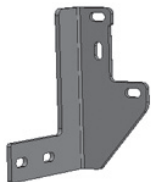

Passenger/Right
Frame Bracket



Driver/Left
Frame Bracket



Passenger/Right
Tube Bracket



Driver/Left
Tube Bracket

NOTE: Not compatible with optional full coverage factory aluminum skid plate. Optional skid plate must be removed and cannot be reinstalled. Cutting may be required (2016 models).

Parts List

- x1 Tyger Guard
- x1 Driver/Left Frame Mounting Bracket
- x1 Passenger/Right Frame Mounting Bracket
- x1 Driver/Left Tube Mounting Bracket
- x1 Passenger/Right Tube Mounting Bracket
- x2 10-1.50mm x 120mm x 30mm Hex Bolts
- x4 10-1.50mm x 35mm Hex Bolts
- x12 10mm x 27mm x 3mm Flat Washers
- x4 10mm Nylon Lock Nuts
- x4 8-1.25mm x 35mm Hex Bolts
- x4 8mm x 22mm OD x 2mm Flat Washers
- x2 6mm-1.0 x 20mm Comb Bolts (license plate)
- x4 Large Spacer Washers
- x2 10mm Lock Washers
- x2 10mm Hex Nuts
- x4 8mm Lock Washers
- x1 4mm Wrench (6mm Combo Bolt)



TYGER[®]

STEP 1

For 2016-UP models only, remove the plastic lower air dam from the bottom of the front bumper, (Fig 1).

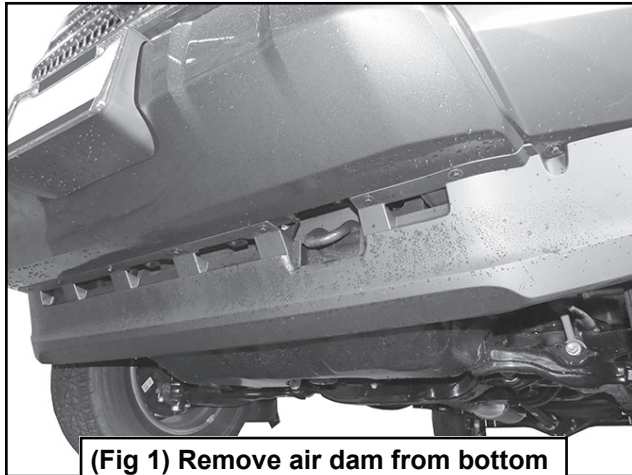

(Fig 1) Remove air dam from bottom of bumper (2016 models only)

STEP 2

Start installation at the passenger side, front of the vehicle. Remove the (2) outer factory hex nuts attaching the aluminum bumper mount to the end of the frame, (Fig 2).

NOTE: It may be necessary to temporarily remove the factory tow hook from the passenger side.

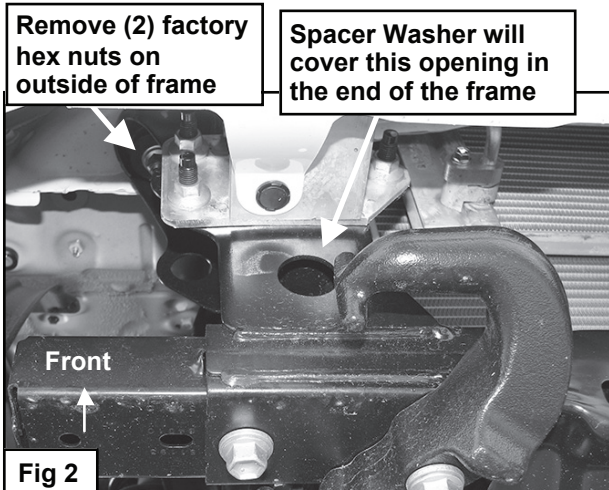
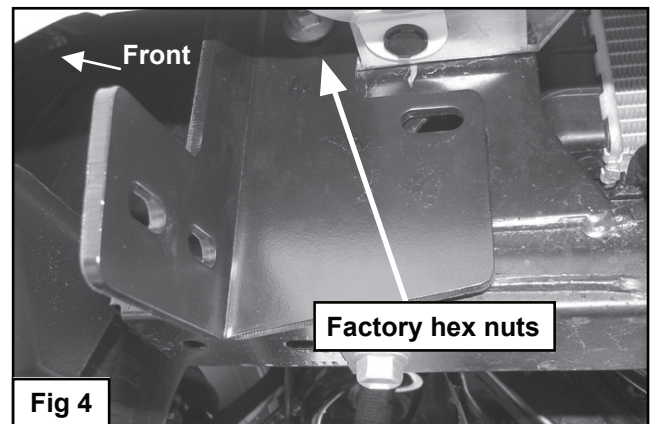
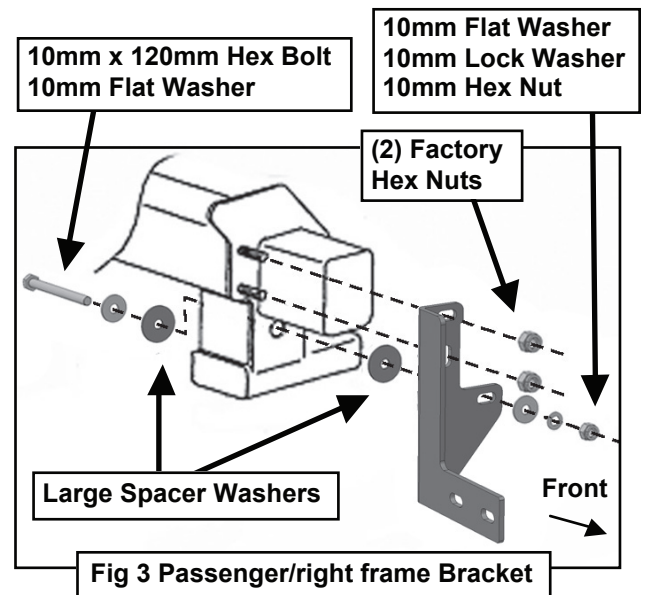

Fig 2

STEP 3

Select the passenger side Frame Bracket, (Fig 3). Slide the Bracket over the (2) studs. Use the factory hex nuts to attach the Bracket to the studs, (Figs 3-4). Leave hardware loose.



STEP 4

Slide (1) Large Spacer Washer between the Mounting Bracket and the frame cross member, (Figs 3, 5-6). Insert (1) 10mm x 120 mm Hex Bolt with (1) 10mm Flat Washer and (1) Large Spacer Washer into and through the hole in the back of the cross member. Make sure the Spacer Washer is against the cross member



TYGER[®]

covering the large hole, (Figs 3 & 7). Push the long bolt through the outer Spacer Washer and Frame Bracket. Attach the Bracket to the Bolt with (1) 10mm Flat Washer, (1) 10mm Lock Washer and (1) 10mm Hex Nut, (Figs 3 & 8). Leave hardware loose at this time.

NOTE: Trim plastic splash guards attached to the bottom corners of the bumper as necessary to clear brackets.

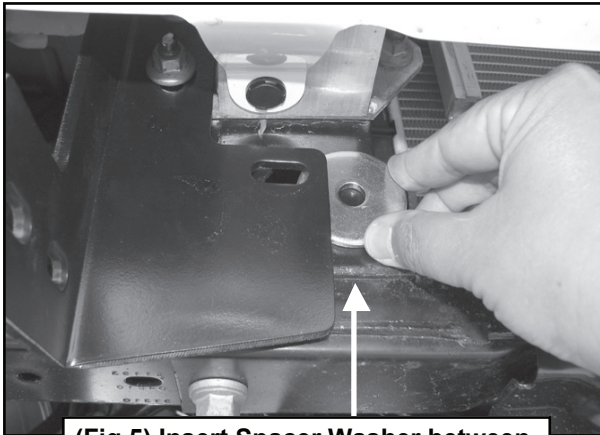

(Fig 5) Insert Spacer Washer between the Mounting Bracket and the frame

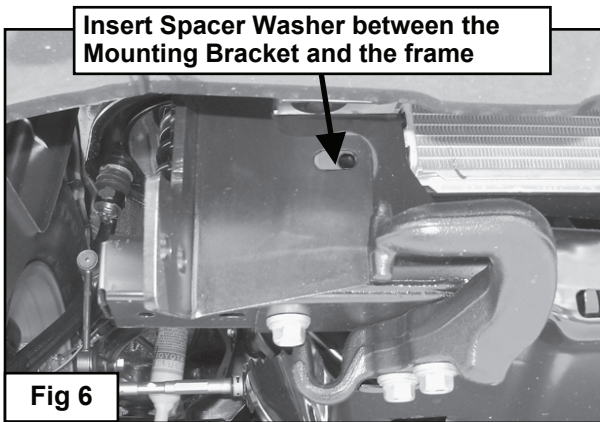

Insert Spacer Washer between the Mounting Bracket and the frame

Fig 6

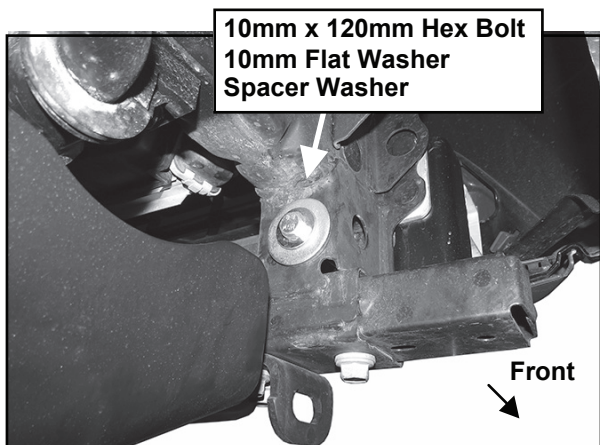

**10mm x 120mm Hex Bolt
10mm Flat Washer
Spacer Washer**

Front

(Fig 7) Passenger side pictured from behind bumper

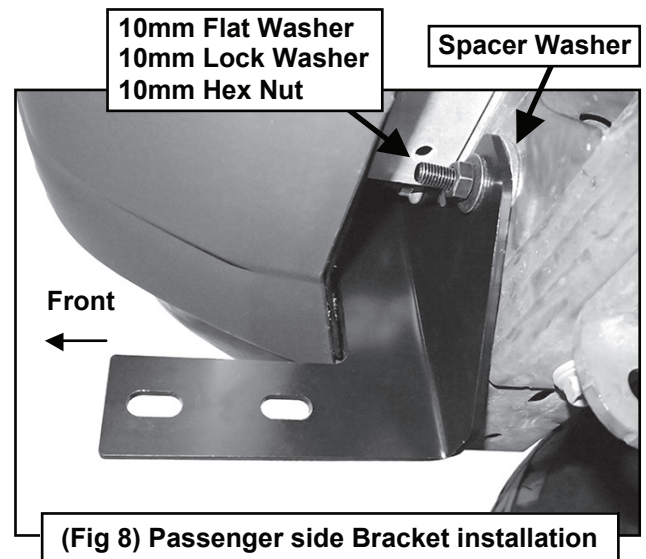

**10mm Flat Washer
10mm Lock Washer
10mm Hex Nut**

Spacer Washer

Front

(Fig 8) Passenger side Bracket installation

STEP 5

Repeat Steps 2-4 for driver/left side Bracket installation.

STEP 6

Select the passenger/right Tube Mounting Bracket, (Fig 9). Attach the Bracket to the end of the Tyger Guard with (2) 8mm x 35mm Hex Bolts, (2) 8mm Lock Washers and (2) 8mm Flat Washers. Center the mounting flange on the Bracket with the end of the tube. Do not tighten hardware. Repeat this Step to attach the driver/left side Tube Bracket.

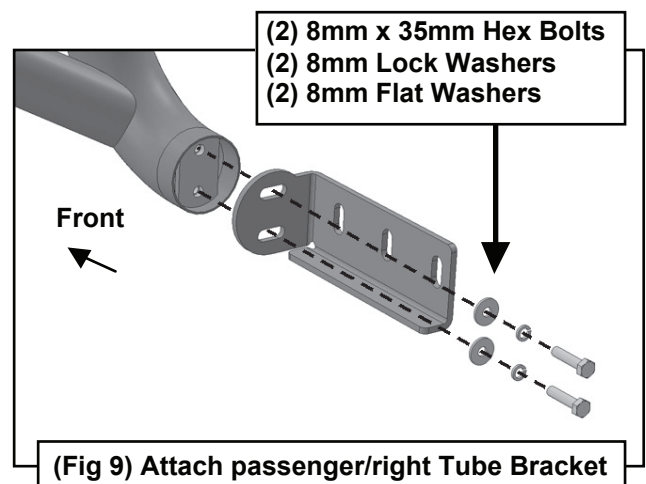

**(2) 8mm x 35mm Hex Bolts
(2) 8mm Lock Washers
(2) 8mm Flat Washers**

Front

(Fig 9) Attach passenger/right Tube Bracket



TYGER[®]

STEP 7

For 2016-UP models only:

Hold the plastic air dam up in position against the Mounting Brackets. Trace the location of the two Brackets onto the back of the air dam, (Fig 10). Use a sharp knife or hacksaw blade to carefully cut two slots to clear the brackets.

IMPORTANT: Do not cut through the top or bottom edge of the air dam. Do not cut off the mounting tabs from the top of the air dam. For best results, check all measurements before cutting. Start with a small opening and slowly enlarge the slots until Brackets and Tyger Guard clear the air dam. Reinstall the air dam but leave hardware loose.

Do not cut through the top or bottom edge of the air dam. Do not cut off the mounting tabs from the top of the air dam.!

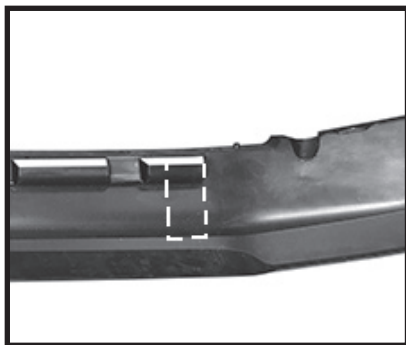

(Fig 10) Dashed lines represent approximate area to cut from air dam and are illustrated for example only

STEP 8

With assistance, line up the mounting tabs on the Tyger Guard and Brackets with the outside of the (2) previously installed Frame Brackets.

2005-2015 Models:

a. Attach the Tube Brackets to the center and rear holes in the Frame Brackets with the included (4) 10mm x 35mm Hex Bolts, (8) 10mm Flat Washers and (4) 10mm Nylon Lock Nuts, (Figs 11-12). Do not tighten hardware at this time.

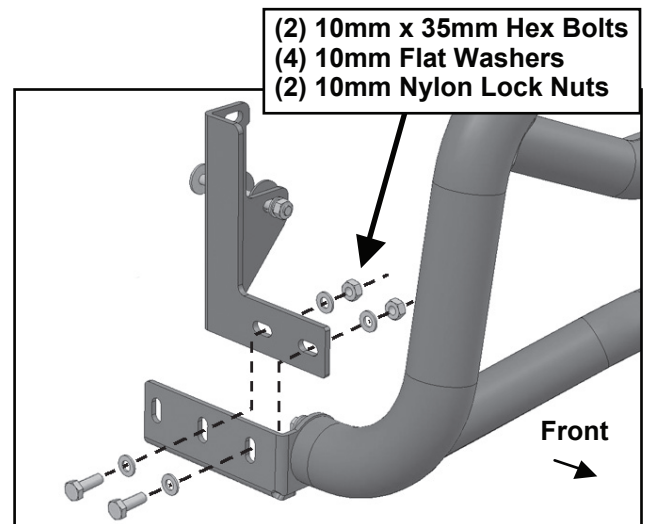

(Fig 11) 2005-15 models, attach Bull Bar with Brackets to center and forward mounting slots

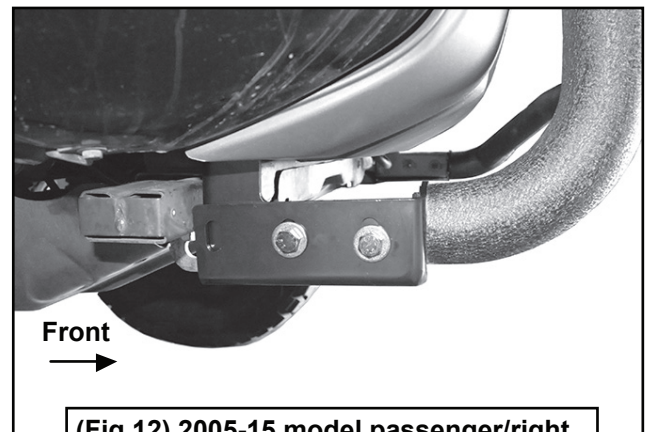

(Fig 12) 2005-15 model passenger/right complete installation



TYGER[®]

2016-UP Models:

- a. Trim air dam for clearance around Brackets if required.
- b. Attach the Tube Brackets to the forward and center holes in the Frame Brackets with the included (4) 10mm x 35mm Hex Bolts, (8) 10mm Flat Washers and (4) 10mm Nylon Lock Nuts, (Figs 13-14). Do not tighten hardware at this time.

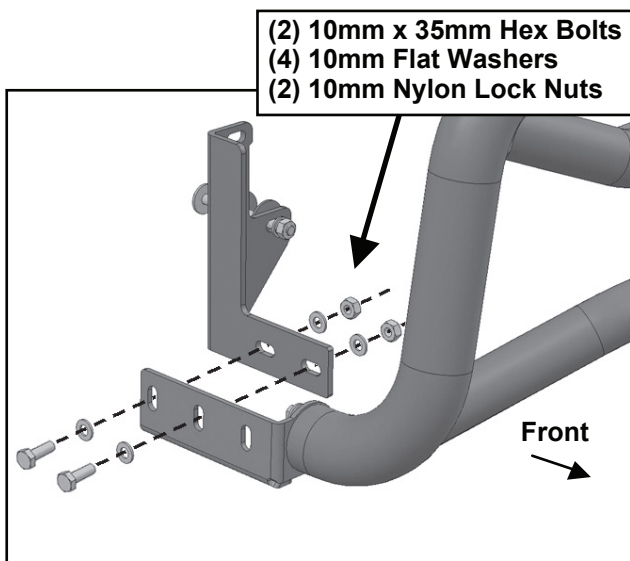

(Fig 13) 2016-on models, attach Bull Bar with Brackets to center and rear mounting slots

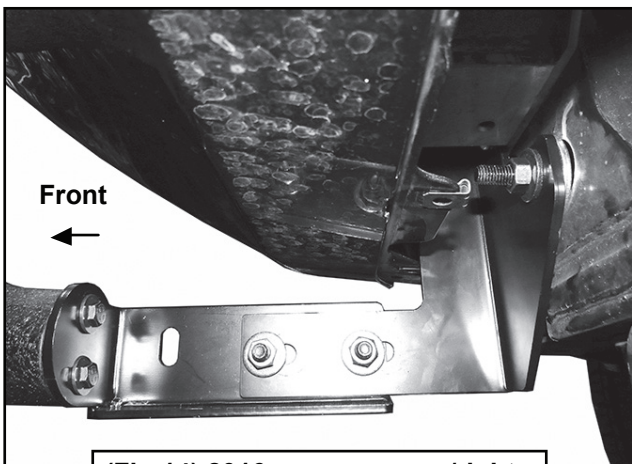

(Fig 14) 2016-on passenger/right complete installation. Trim plastic around brackets as necessary

STEP 9

Level and adjust the Tyger Guard and tighten all hardware including factory hardware attaching the air dam to the vehicle, (2016 models only). Reinstall the tow hook if removed.

1. Attach the license plate, (if required), to the threaded holes in the front of the Tyger Guard with the included (2) 6mm Combo Bolts.
2. Do periodic inspections to the installation to make sure that all hardware is secure and tight.



(Lights excluded in the kit.)