



TYGER[®]

TYGER GUARD[™]

TG-GD6N60168

BEFORE INSTALLATION

READ INSTRUCTIONS CAREFULLY BEFORE STARTING INSTALLATION. REMOVE CONTENTS FROM BOX AND VERIFY ALL PARTS ARE PRESENT. ASSISTANCE IS RECOMMENDED. FAILURE TO IDENTIFY DAMAGE BEFORE INSTALLATION COULD LEAD TO A REJECTION OF ANY CLAIM. IF ANY DAMAGE FOUND, PLEASE TAKE A PICTURE FOR THE CLAIM PURPOSE.

WARNING

TEXTURED COATED FINISHES SHOULD BE CLEANED WITH A MILD SOAP ON A DAMP SPONGE. DO NOT APPLY POLISH OR WAX THAT REQUIRES TO BE REMOVED BY MEANS OF BUFFING. THIS TYPE OF WAX IS COMMONLY USED AT CAR WASH FACILITIES.

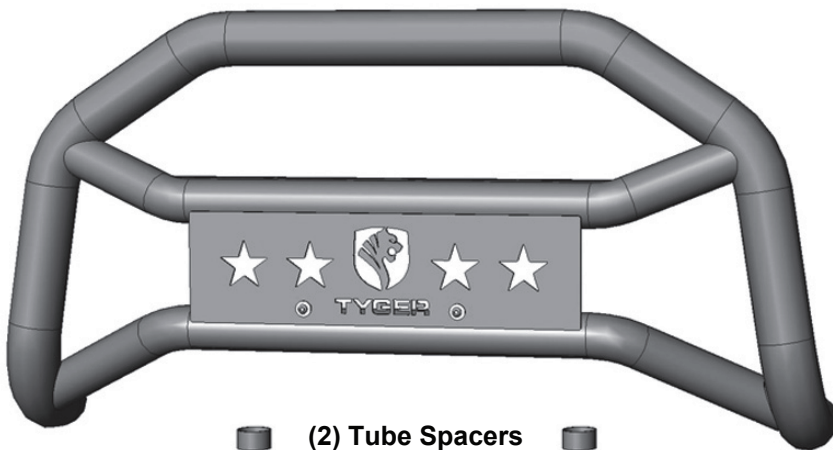

(2) Tube Spacers



Passenger/Left Tube Mounting Bracket



Driver/Right Tube Mounting Bracket



Passenger/Left Frame Mounting Bracket



Driver/Right Frame Mounting Bracket

NOTE: May require cutting. Installation may interfere with front mounted sensors. Not recommended for vehicles with optional "active" laser guided cruise control systems.

Parts List

- x1 Tyger Guard
- x1 Driver/left Frame Mounting Bracket
- x1 Passenger/right Frame Mounting Bracket
- x1 Driver/left Tube Mounting Bracket
- x1 Passenger/right Tube Mounting Bracket
- x2 12-1.25mm x 60mm Fine Thread Hex Bolts
- x2 12-1.25mm x 30mm Fine Thread Hex Bolts
- x4 12mm x 37mm OD x 3mm Flat Washers
- x4 10-1.5mm x 35mm Hex Bolts
- x8 10mm x 27mm x 3mm Flat Washers
- x4 10mm Nylon Lock Nuts
- x4 8-1.25mm x 35mm Hex Bolts
- x4 8mm x 24mm x 2mm Flat Washers
- x2 6-1.0mm x 20mm Combo Bolts
- x4 12mm Lock Washers
- x4 8mm Lock Washers
- x1 4mm Allen Wrench(6mm)
- x2 Spacer Tubes (23mm x 42mm)



TYGER[®]

STEP 1

Remove the factory skid plate and tow hooks from vehicle, if equipped, (Figs 1-3). On models without tow hooks, remove the bent bracket from the bottom of the frame, (Fig 3).

NOTE: Skid plate, brackets and tow hooks cannot be reinstalled.



(Fig 1) Remove skid plate if equipped

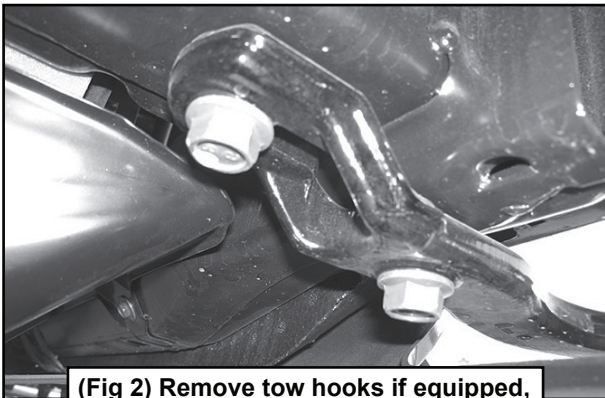

(Fig 2) Remove tow hooks if equipped, (passenger/right tow hook pictured)

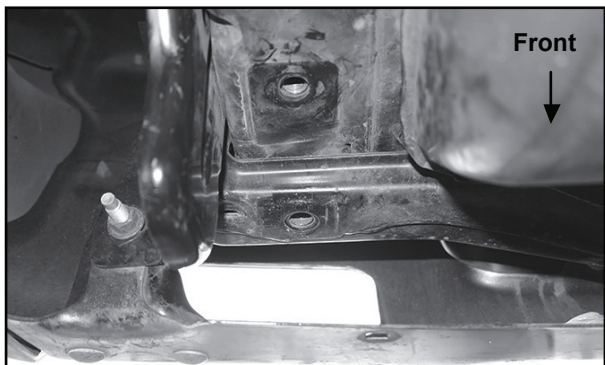

(Fig 3) Models without tow hooks, remove bracket

STEP 2

Select the driver/left Frame Mounting Bracket and (1) Tube Spacer, (Fig 4). Attach the Bracket to the front, (forward), mounting hole on the frame with the included (1) 12mm x 30mm Fine Thread Hex Bolt, (1) 12mm Lock Washer and (1) 12mm Flat Washer, (Figs 4-5). Leave hardware loose.

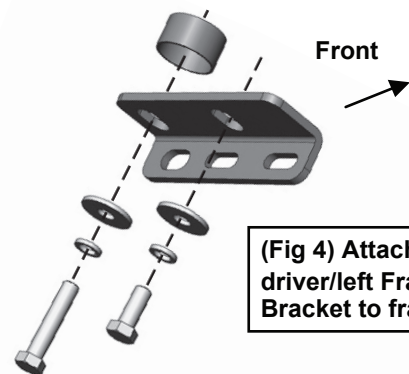

(Fig 4) Attach driver/left Frame Bracket to frame

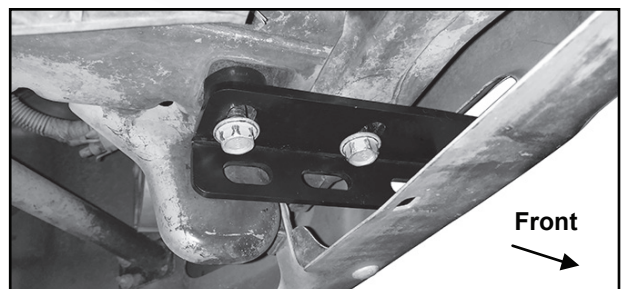

(Fig 5) Attach driver/left Frame Bracket to frame

STEP 3

Slide (1) Tube Spacer between the rear mounting hole on the Bracket and the bottom of the frame. Insert (1) 12mm x 60mm Fine Thread Hex Bolt, (1) 12mm Lock Washer and (1) 12mm Flat Washer through the Bracket, the Tube Spacer and into the Frame, (Figs 4-5). Do not fully tighten hardware at this time.

STEP 4

Repeat Steps 2 & 3 to attach the passenger/right Frame Mounting Bracket.



TYGER[®]

STEP 5

Next, select the driver/left Tube Mounting Bracket, (Fig 6). Attach the Bracket to the end of the tube on the Tyger Guard with (2) 8mm Hex Bolts, (2) 8mm Lock Washers and (2) 8mm Flat Washers, (Figs 6-7). Center the Bracket on the end of the tube but do not fully tighten at this time. Repeat this Step to attach the passenger/right Tube Bracket.

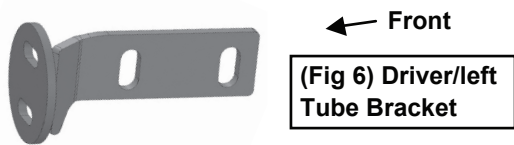

(Fig 6) Driver/left Tube Bracket

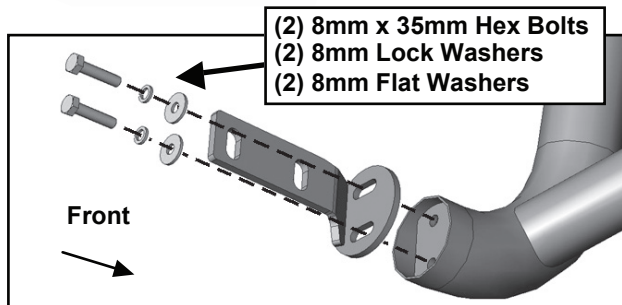

(Fig 7) Attach driver/left Tube Bracket to end of tube

STEP 6

With assistance, hold the Tyger Guard assembly with Brackets up to the vehicle. Insert the Brackets through the openings in the bumper and up to the Frame Brackets. Attach the Tube Brackets to the Frame Brackets with (4) 10mm x 35mm Hex Bolts, (4) 10mm Flat Washers and (4) 10mm Nylon Lock Nuts, (Figs 8-9).

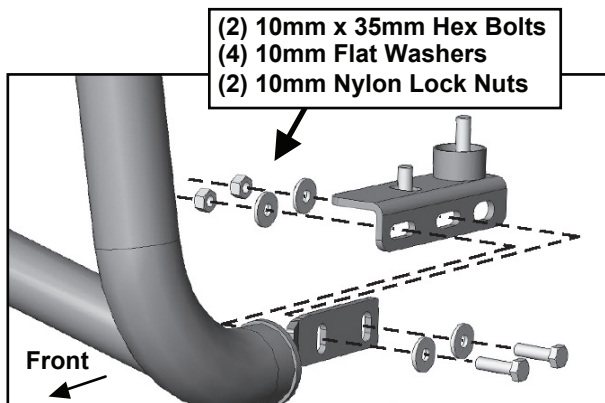

(Fig 8) Attach Tube Bracket to Frame Bracket

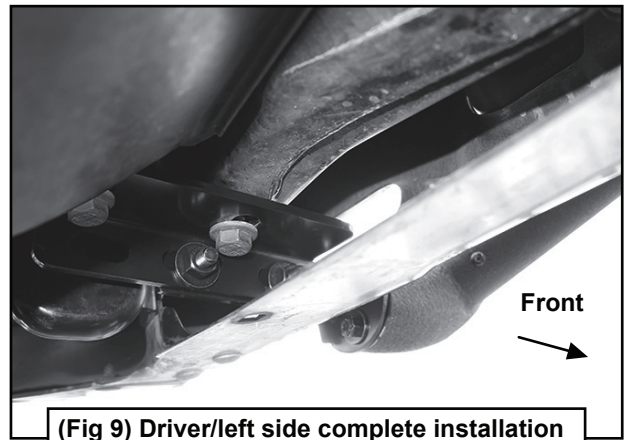

(Fig 9) Driver/left side complete installation

STEP 7

Align Tyger Guard properly with vehicle and fully tighten all hardware.

STEP 8

Do periodic inspections to the installation to make sure that all hardware is secure and tight.

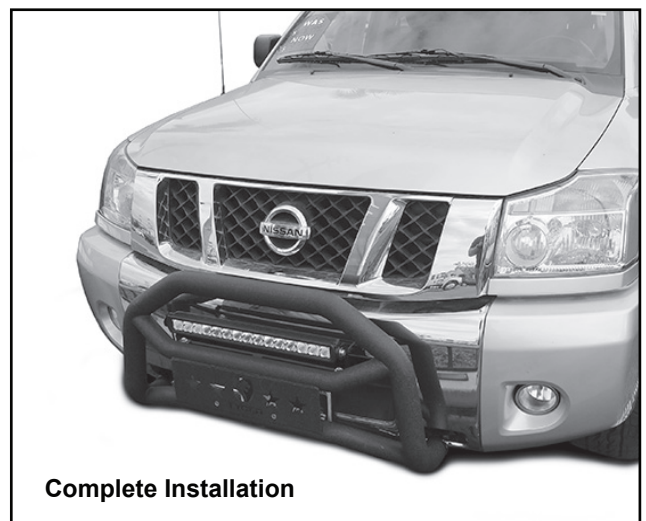

Complete Installation