



TYGER®

TYGER GUARD™

TG-GD6F60098

BEFORE INSTALLATION

READ INSTRUCTIONS CAREFULLY BEFORE STARTING INSTALLATION. REMOVE CONTENTS FROM BOX AND VERIFY ALL PARTS ARE PRESENT. ASSISTANCE IS RECOMMENDED. CUTTING IS REQUIRED. FAILURE TO IDENTIFY DAMAGE BEFORE INSTALLATION COULD LEAD TO A REJECTION OF ANY CLAIM. IF ANY DAMAGE FOUND, PLEASE TAKE A PICTURE FOR THE CLAIM PURPOSE.

WARNING

TEXTURED COATED FINISHES SHOULD BE CLEANED WITH A MILD SOAP ON A DAMP SPONGE. DO NOT APPLY POLISH OR WAX THAT REQUIRES TO BE REMOVED BY MEANS OF BUFFING. THIS TYPE OF WAX IS COMMONLY USED AT CAR WASH FACILITIES.

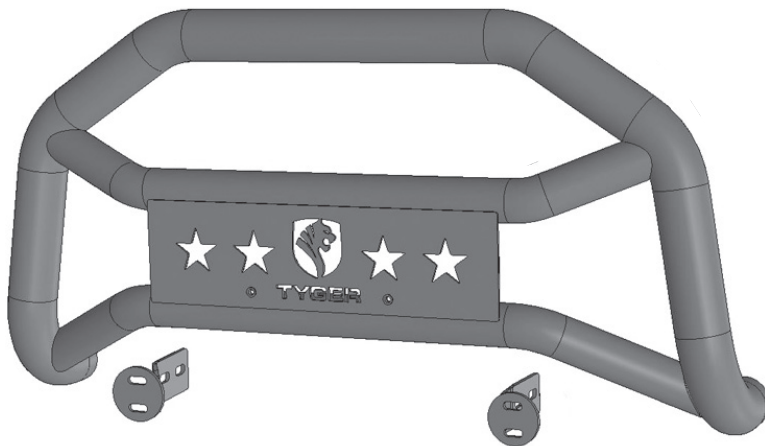

Passenger/Right Bull Bar Mounting Bracket

Driver/Left Side Bull Bar Mounting Bracket

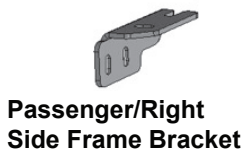

Parts List

- x1 Tyger Guard
- x1 Driver/left Frame Bracket
- x1 Passenger/right Frame Bracket
- x1 Driver/left Mounting Bracket
- x1 Passenger/right Mounting Bracket
- x4 12mm Lock Washers
- x4 12-1.75mm Hex Nuts
- x4 12mm x 40mm Bolt Plates
- x4 12mm x 32mm OD x 3mm Flat Washer
- x2 10mm U-Bolt (for use on "closed frames" only)
- x4 10-1.50mm x 35mm Hex Bolts
- x12 10mm x 27mm OD x 3mm Flat Washers
- x4 10mm-1.50 Nylon Lock Nuts
- x4 10mm Lock Washers
- x4 10mm-1.50 Hex nuts
- x4 8mm x 22mm OD x 2mm Flat Washers
- x4 8-1.25mm x 35mm Hex Bolts
- x4 8mm Lock Washers
- x2 6-1.0mm x 20mm Combo Bolts
- x1 Wrench S=4



TYGER[®]

STEP 1

Determine if the vehicle is equipped with tow hooks, (Fig 1).

Vehicles with Factory Tow Hooks

(NOTE: Tow hooks cannot be reinstalled)

a. Remove each tow hook by removing the front bolt and only loosening the rear bolt, (Fig 2). Slide the tow hook off. Keep the factory double nut plate in the frame and aligned with the holes. NOTE: On 15-UP models, first remove tow hook. Pull seal around tow hook in toward vehicle to release from back of bumper. Once released from bumper, pull seal out through tow hook opening. Seal cannot be reinstalled.

Remove tow hooks if equipped

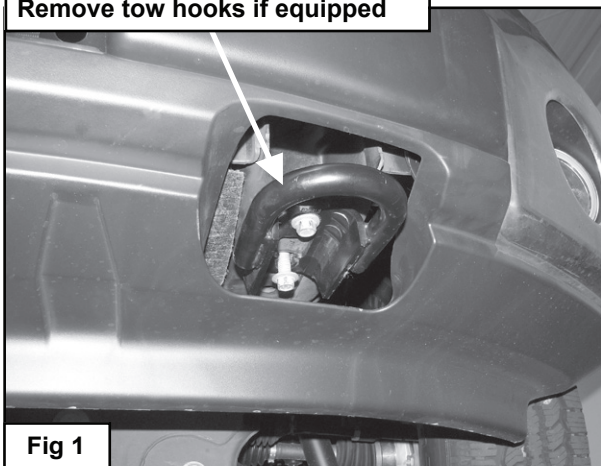

Fig 1

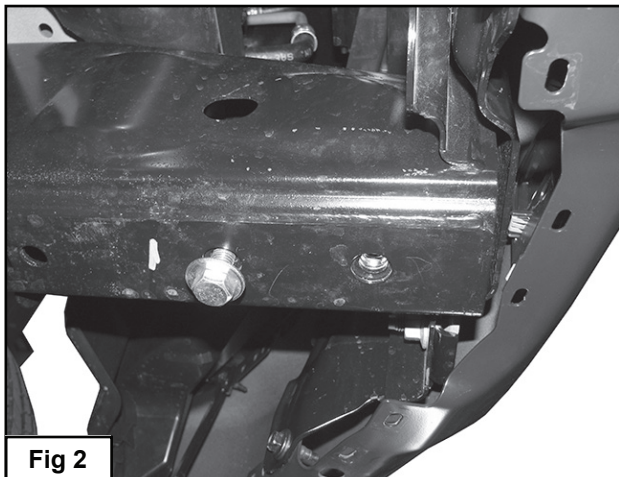
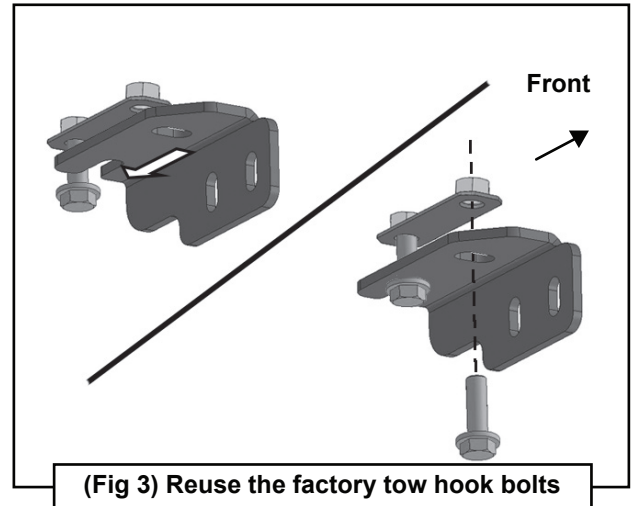

Fig 2

b. Select the driver side Frame Bracket. Position the Bracket up to the bottom of the frame. Reuse the tow hook hardware to attach the Bracket to the bottom of the frame and factory double nut plate, (Fig 3).



c. Repeat to install the passenger side Frame Bracket.

d. Skip to Step 2.



TYGER[®]

All vehicles without Tow Hooks

Remove the lower plastic portion of the bumper to gain access to the ends of the frame rails, (Fig 4). The lower bumper or splash guard will need to be cut out to allow the Mounting Brackets and end of Bull Bar to pass through, (Step 4). On some models, access to the mounting hardware is limited. For access, first remove the plastic bumper cover from each side of the opening and in the center of the bumper, (Fig 5).



(Fig 4) Temporarily remove the splash guard as required to gain access to the front of the frame channel.!



(Fig 5) Remove bumper pads to access splash guard hardware if necessary. 2015 F150 pictured

Vehicles without Tow Hooks and open end of frame

a. Starting on the driver side of the vehicle, insert (2) 12mm Bolt Plates through the opening in the end of the frame and down through the hole in the bottom of the frame, (Figs 6 & 7).

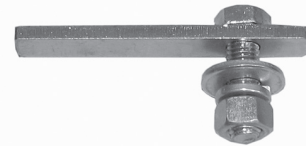

(Fig 6) 12mm x 40mm Bolt Plates

(2) 12mm x 40mm Bolt Plates
(2) 12mm Lock Washers
(2) 12mm Flat Washers
(2) 12mm Hex Nuts

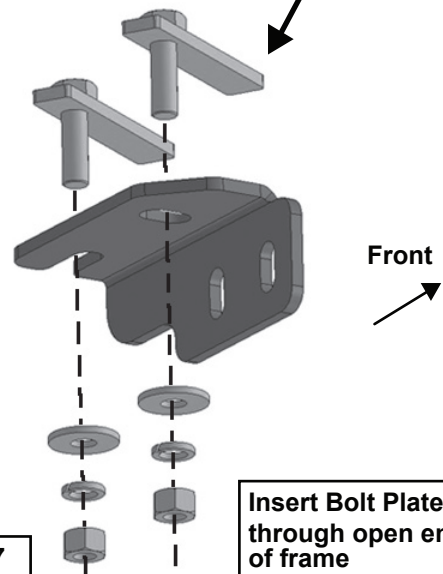

Fig 7

Insert Bolt Plates through open end of frame

b. Attach the Bracket to the Bolt Plates with (2) 12mm Flat Washer, (2) 12mm Lock Washers and (2) 12mm Hex Nuts, (Fig 7).

c. Snug but do not tighten the hardware.

d. Repeat to install the passenger side frame Bracket.



TYGER[®]

Vehicles without Tow Hooks, closed end of frame

a. Starting on the driver side of the vehicle, locate the two holes on the bottom of the frame. Insert (1) 10mm U-Bolt into one hole and out the other, (U-Bolt is only used on vehicles with "closed end frames") (Figs 8 & 9).

(Fig 8) 10mm U-Bolt

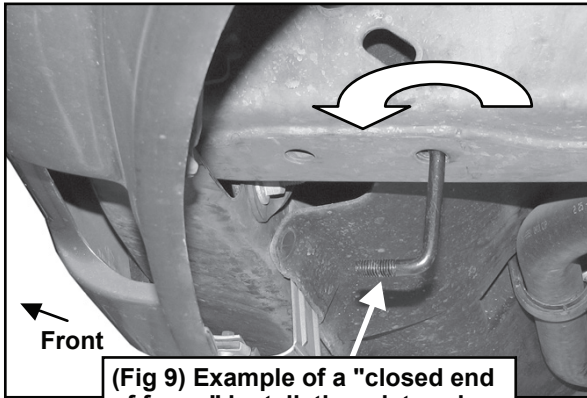

(Fig 9) Example of a "closed end of frame" installation pictured

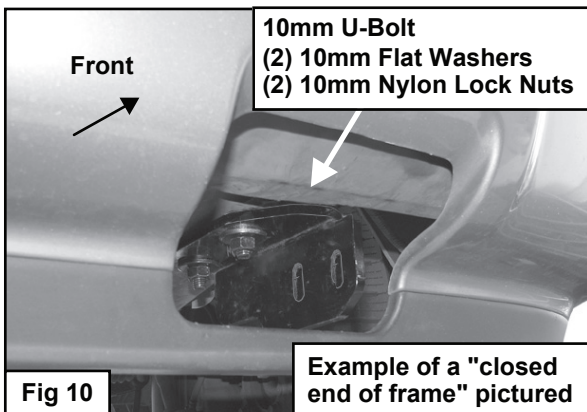

Fig 10

Example of a "closed end of frame" pictured

b. Attach the driver side Frame Bracket to the U-Bolt with (2) 10mm Flat Washers and (2) 10mm Nylon Lock Nuts, (Fig 10).

c. Snug but do not tighten the hardware.

d. Repeat to install the passenger side frame Bracket.

STEP 2

Next, carefully unwrap the Tyger Guard. Select the driver side Mounting Bracket, (Fig 11). Attach the Bracket to the end of the tube with (2) 8mm x 35mm Hex Bolts, (2) 8mm Lock Washers and (2) 8mm Flat Washers, (Fig 12). Center the mounting flange on the Bracket with the end of the tube. Snug but do not tighten hardware. Repeat this Step to install the passenger side Mounting Bracket.

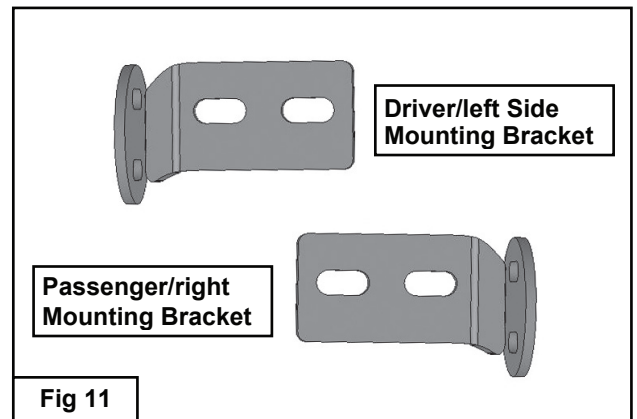

Fig 11

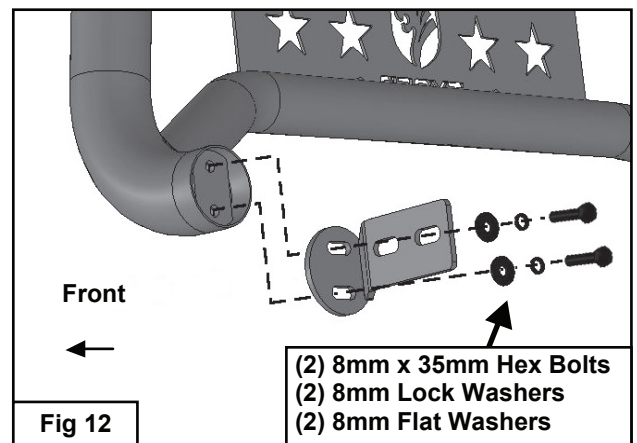

Fig 12

(2) 8mm x 35mm Hex Bolts
(2) 8mm Lock Washers
(2) 8mm Flat Washers



TYGER[®]

STEP 3

With assistance, line up the mounting tabs on the Bull Bar with the inside of the (2) previously installed Frame Mounting Brackets. Attach the Tyger Guard to the Brackets with the included (4) 10mm x 35mm Hex Bolts, (8) 10mm Flat Washers, (4) 10mm Lock Washers and (4) 10mm Hex Nuts, (Fig 13). Snug but do not tighten hardware at this time.

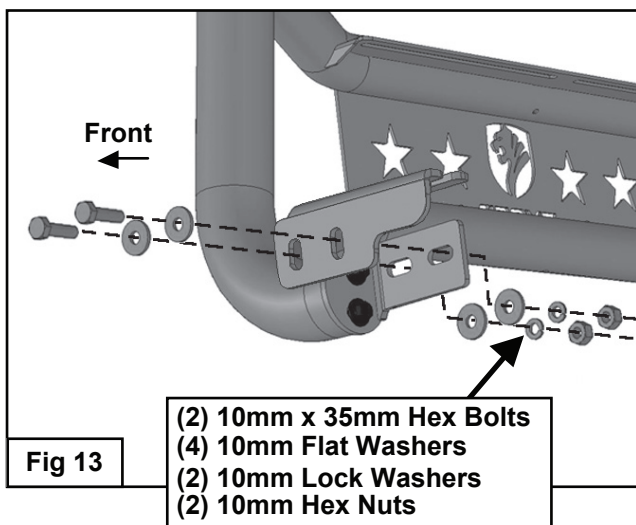

STEP 4

Level and adjust the Tyger Guard properly and tighten all hardware.

Models without openings in lower bumper/splash guard for tow hooks.

- Hold the splash guard up to the bottom of the bumper and Brackets, (Fig 14). Trace the location of both Brackets onto the back of the cover, (Fig 15).
- Temporarily remove the Tyger Guard with attached Tube Brackets only.
- Cut openings in the cover to clear the Frame Brackets and end of Bull Bar as necessary. For best results, start with a small slot and slowly enlarge the opening to clear the Brackets.
- Once cover is properly fit to the Brackets, reinstall the cover and Tyger Guard as previously described.
- Fully tighten all hardware.

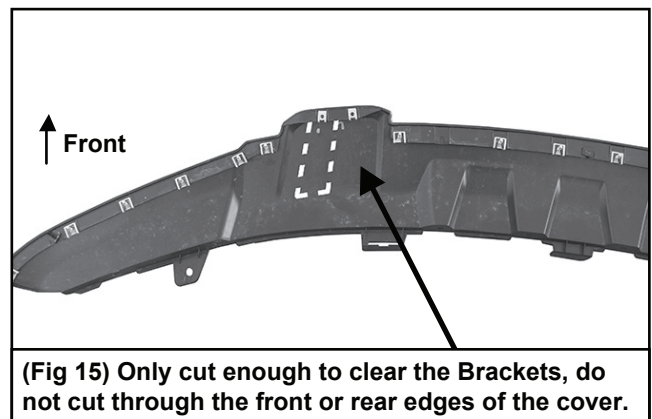
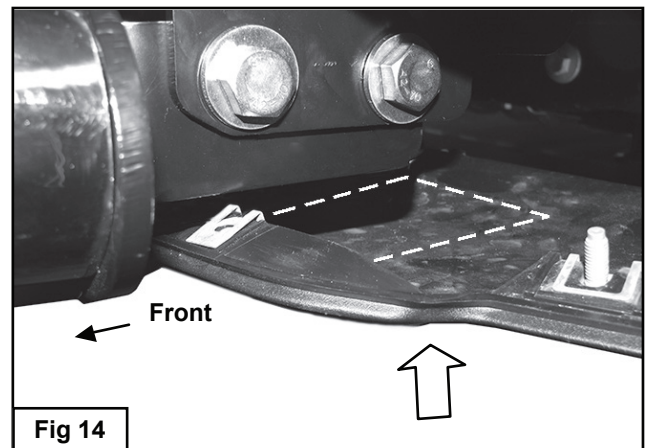



TYGER[®]

STEP 5

Attach the license plate, (if required), to the threaded holes in the front of the Tyger Guard with (2) 6mm Combo Bolts, (Fig 16).

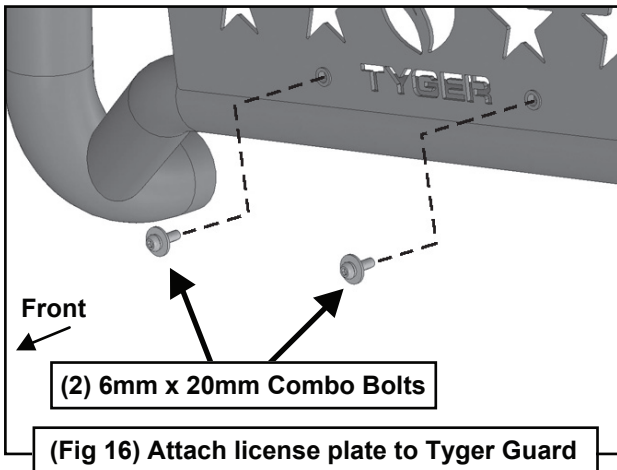

STEP 6

Do periodic inspections to the installation to make sure that all hardware is secure and tight.

