

WHY TYGER?

THE QUALITY YOU CAN TRUST.

To ensure the perfect finish of our black bars and for better rust resistance, we focus every procedure during production including the Pre-treatment and E-Coat before the Black Powder coating. Meanwhile, some similar products in the market reduce their costs by ignoring our first two key procedures.

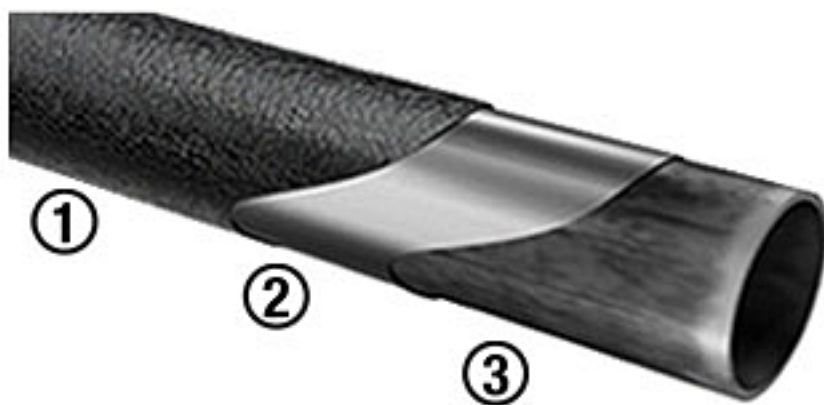

HOW WE DO IT

- ① Pre-treatment to remove impurities
- ② Special "E-Coat" Inside & Out
- ③ Dual-Stage Textured Black Powder

E-COAT

Consistency - uniform density
Durability - 1000Hrs+ of salt spray resistance
Electrodeposition - uses electrical current to deposit the paint

PRE-TREATMENT

Phosphate- a smoother & stable surface
Acid Washing - removes rust
Oil Degreasing - rust and corrosion resistance.

RESULTS WITHOUT PRE-TREATMENT AND E-COAT



Paint bubbles



Rust dust

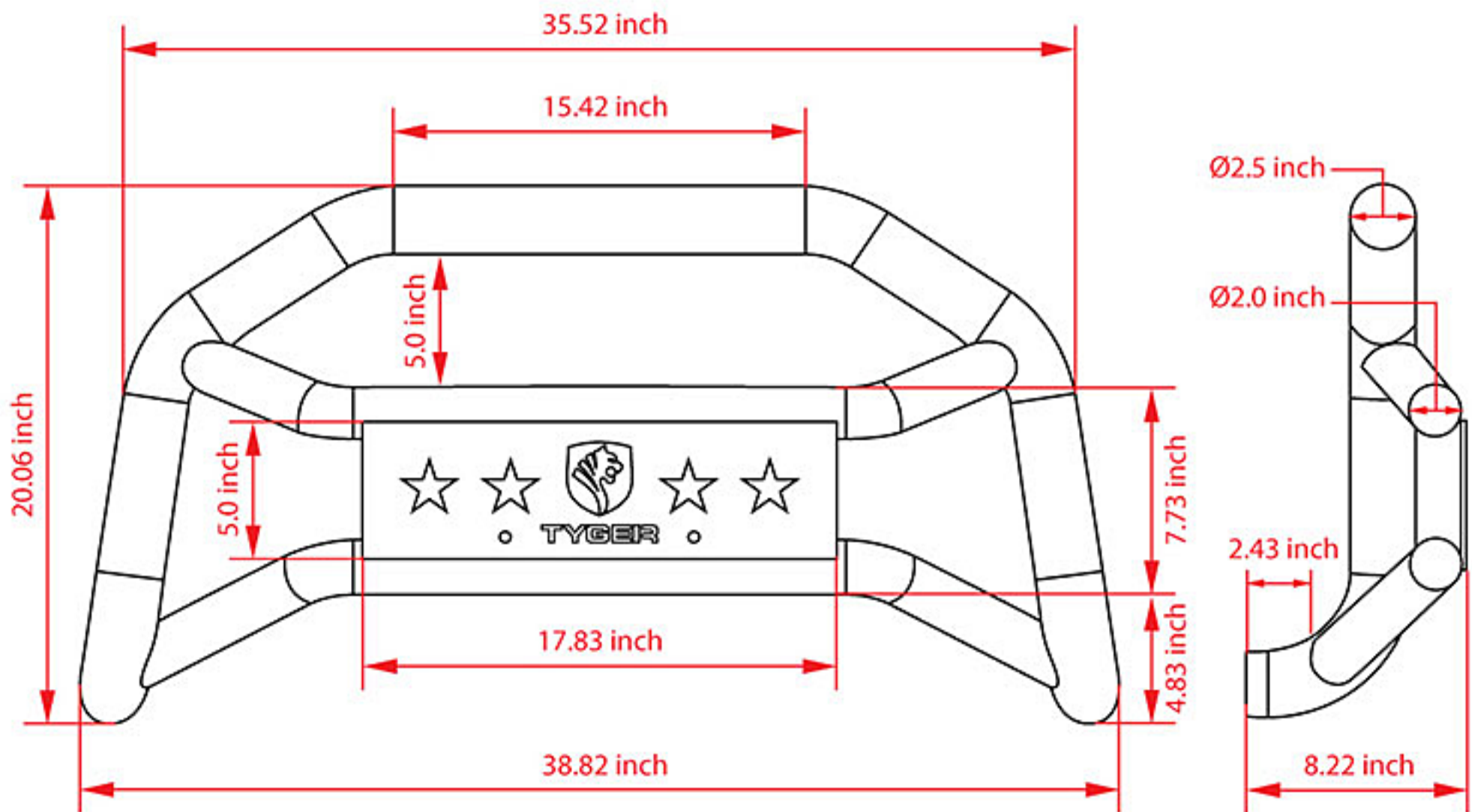

All mounting hardware and DIY instruction included.



Pre-welded channel for light mounting.

(Lights NOT included.)



TG-GD2U28888

Pre-welded light mount channel behind the middle cross bar for LED lights up to 18inch in width. For the 20inch LED light bar, you may need extra bracket #TG-GD2U27777 to mount on.

For lights over 5inch, you can mount them on the top cross bar with extra TYEGR light clamps TG-GD2U28888 which are sold separately.



Two pre-drilled holes for license plate relocation, if needed.

