



TYGER®

TYGER GUARD™

BEFORE INSTALLATION

READ INSTRUCTIONS CAREFULLY BEFORE STARTING INSTALLATION. REMOVE CONTENTS FROM BOX AND VERIFY ALL PARTS ARE PRESENT. ASSISTANCE IS RECOMMENDED. FAILURE TO IDENTIFY DAMAGE BEFORE INSTALLATION COULD LEAD TO A REJECTION OF ANY CLAIM. IF ANY DAMAGE FOUND, PLEASE TAKE A PICTURE FOR THE CLAIM PURPOSE.

WARNING

TEXTURED COATED FINISHES SHOULD BE CLEANED WITH A MILD SOAP ON A DAMP SPONGE. DO NOT APPLY POLISH OR WAX THAT REQUIRES TO BE REMOVED BY MEANS OF BUFFING. THIS TYPE OF WAX IS COMMONLY USED AT CAR WASH FACILITIES.



Passenger/Right
Side Frame
Mounting Bracket

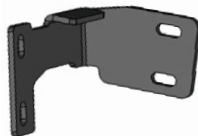

Driver/Left Side
Frame Mounting
Bracket

TG-GD6D60108

NOTE: Tow hooks cannot be reinstalled with the tyger guard.

Parts List

- x1 Tyger Guard
- x1 Driver/Left Frame Mounting Bracket
- x1 Passenger/Right Frame Mounting Bracket
- x2 6mm-1.0 x 20mm Combination Bolts (license plate)
- x8 10-1.5mm x 35mm Hex Bolts
- x16 10mm x 27mm OD x 3mm Flat Washers
- x4 10mm Lock Washers
- x4 10-1.5mm Nylon Lock Nuts
- x4 10-1.5mm Hex Nuts
- x1 Wrench (allen bolt) S=4



TYGER[®]

STEP 1

Starting at the front of the vehicle, determine if the truck is equipped with tow hooks, (Fig 1).

For models without tow hooks:

a. Select the driver side Frame Bracket. Attach the Bracket to the (2) outer holes in the frame with the included (2) 10mm x 35mm Hex Bolts, (4) 10mm Flat Washers, (2) 10mm Lock Washers and (2) 10mm Hex Nuts, (Fig 2-4). Snug the hardware but do not tighten at this time.

b. Repeat this step for passenger side Frame Mounting Bracket installation

For models with tow hooks:

a. Remove the (4) hex bolts attaching the tow hook to the frame, (Fig 1), and remove the tow hook, (Fig 2).

TIP: Removing the inner hex bolts securing each tow hook can be difficult to reach from behind the bumper, (long socket extensions required). It may be easier to access the (2) hex bolts by going through the front of the bumper opening and holding the hex nuts in place with an open-ended wrench.

b. Select the driver side Mounting Bracket. Attach the Bracket to the (2) outer holes for the tow hook with the factory hardware or the included (2) 10mm x 35mm Hex Bolts, (4) 10mm Flat Washers, (2) 10mm Lock Washers and (2) 10mm Hex Nuts, (Fig 2-4). Snug the hardware but do not tighten at this time.

Remove factory tow hook if equipped

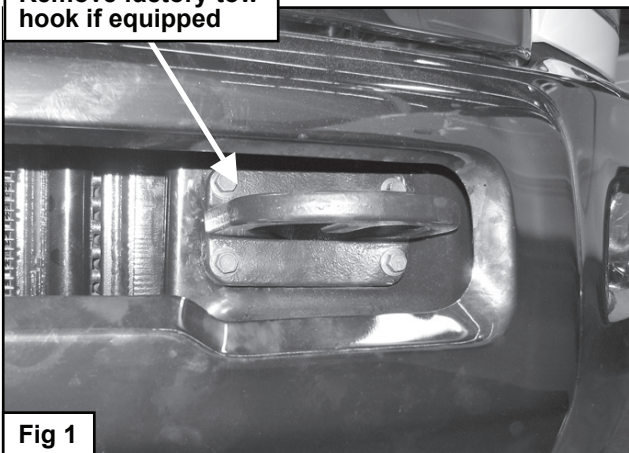

Fig 1

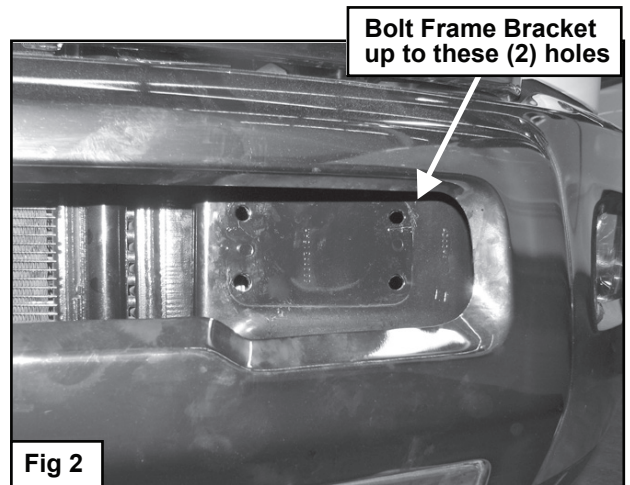

Fig 2

Use the factory tow hook hardware or the included:
(2) 10mm x 35mm Hex Bolts
(4) 10mm Flat Washers
(2) 10mm Lock Washers
(2) 10mm Hex Nuts

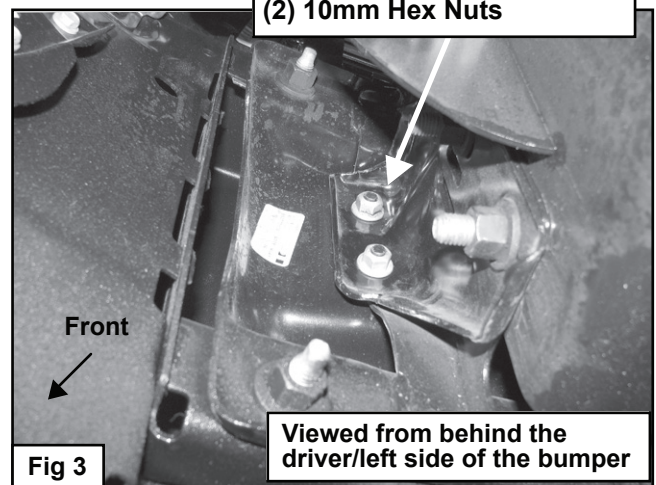
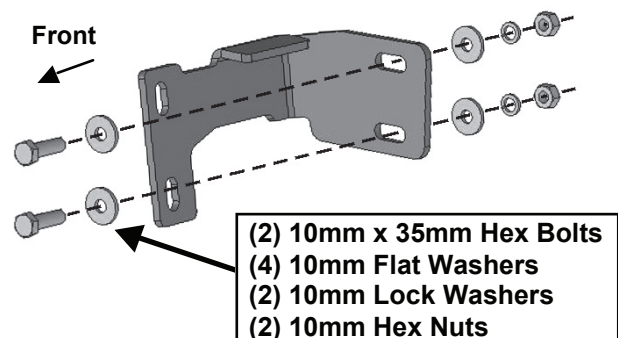

Fig 3

Fig 4



(2) 10mm x 35mm Hex Bolts
(4) 10mm Flat Washers
(2) 10mm Lock Washers
(2) 10mm Hex Nuts



TYGER[®]

STEP 2

Repeat Step 1 for passenger side Mounting Bracket installation.

STEP 3

With help, position the Bull Bar up to the inside of the Mounting Brackets. Attach the Bull Bar to the Brackets with the included (4) 10mm x 35mm Hex Bolts, (8) 10mm Flat Washers, (4) 10mm Nylon Lock Nuts, (Fig 5). Snug but do not tighten hardware.

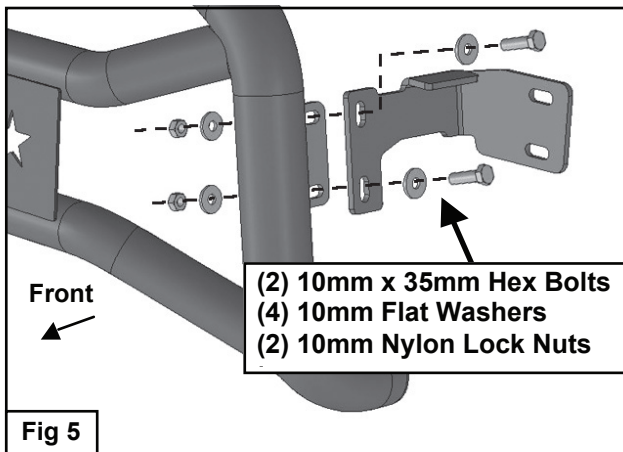

STEP 4

Level and adjust the Tyger Guard properly and tighten all hardware.

STEP 5

Attach the license plate, (if required), to the threaded holes in the front of the Tyger Guard with (2) 6mm Combo Bolts, (Fig 6).

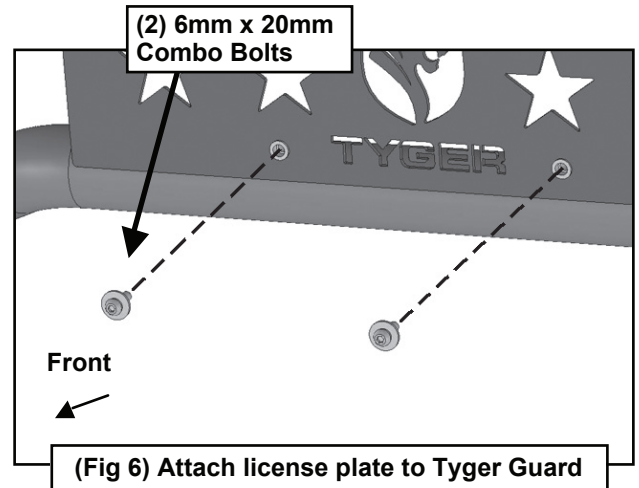

STEP 6

Do periodic inspections to the installation to make sure that all hardware is secure and tight.