

# WHY TYGER?

## THE QUALITY YOU CAN TRUST.

To ensure the perfect finish of our black bars and for better rust resistance, we focus every procedure during production including the Pre-treatment and E-Coat before the Black Powder coating. Meanwhile, some similar products in the market reduce their costs by ignoring our first two key procedures.

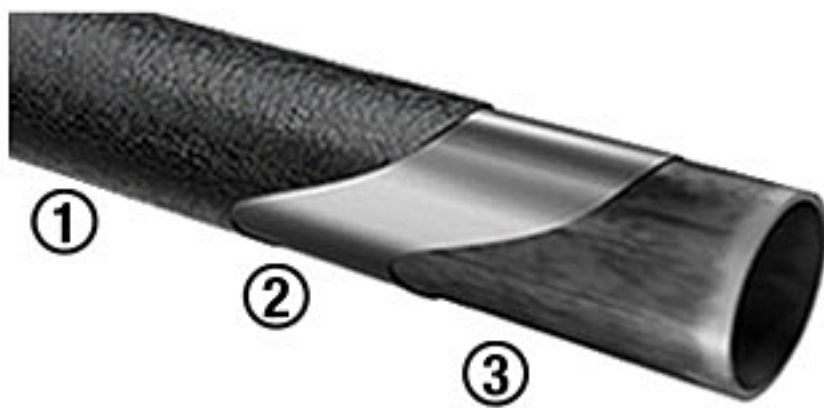

### HOW WE DO IT

- ① Pre-treatment to remove impurities
- ② Special "E-Coat" Inside & Out
- ③ Dual-Stage Textured Black Powder

### E-COAT

**Consistency** - uniform density  
**Durability** - 1000Hrs+ of salt spray resistance  
**Electrodeposition** - uses electrical current to deposit the paint

### PRE-TREATMENT

**Phosphate**- a smoother & stable surface  
**Acid Washing** - removes rust  
**Oil Degreasing** - rust and corrosion resistance.

## RESULTS WITHOUT PRE-TREATMENT AND E-COAT



Paint bubbles



Rust dust

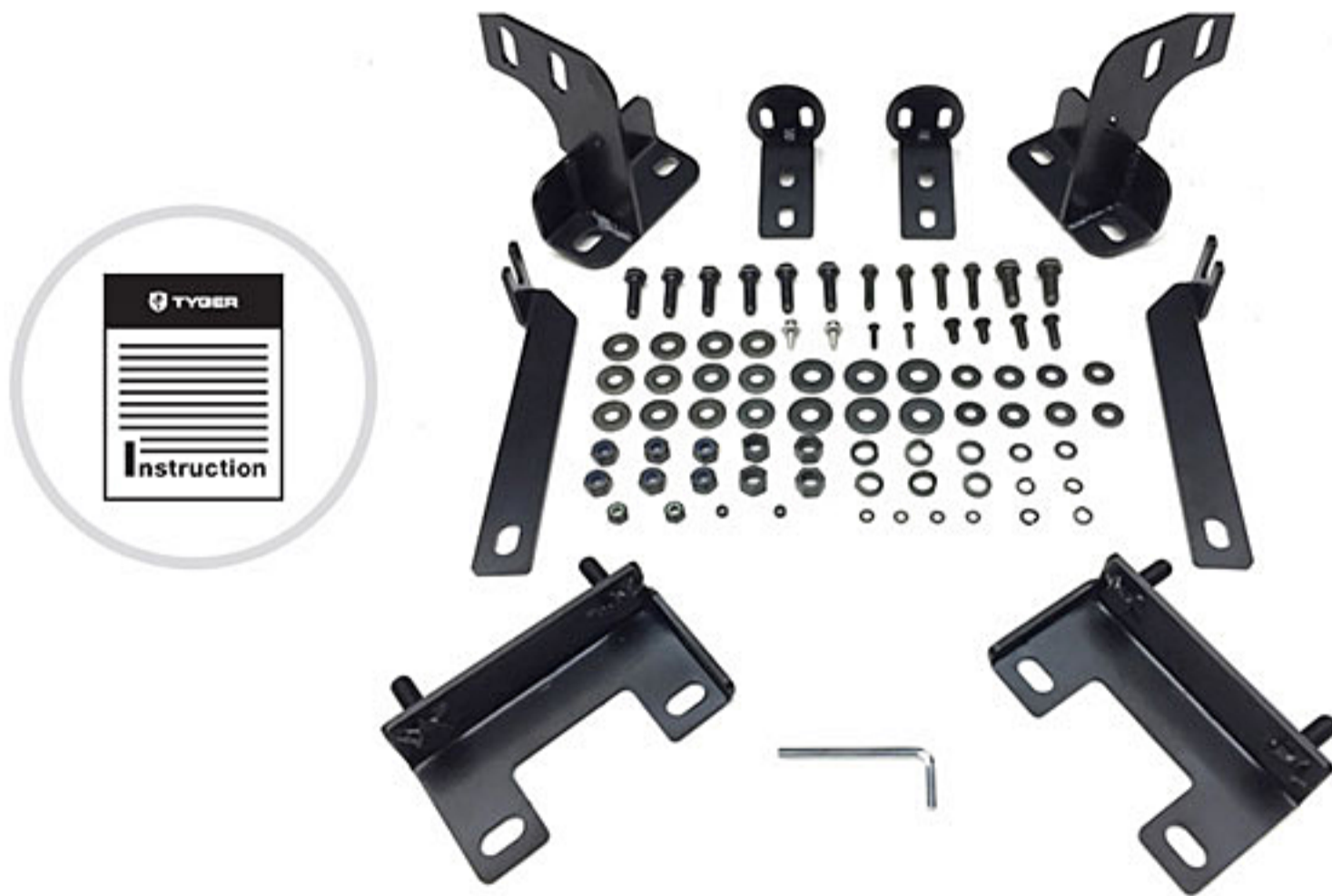
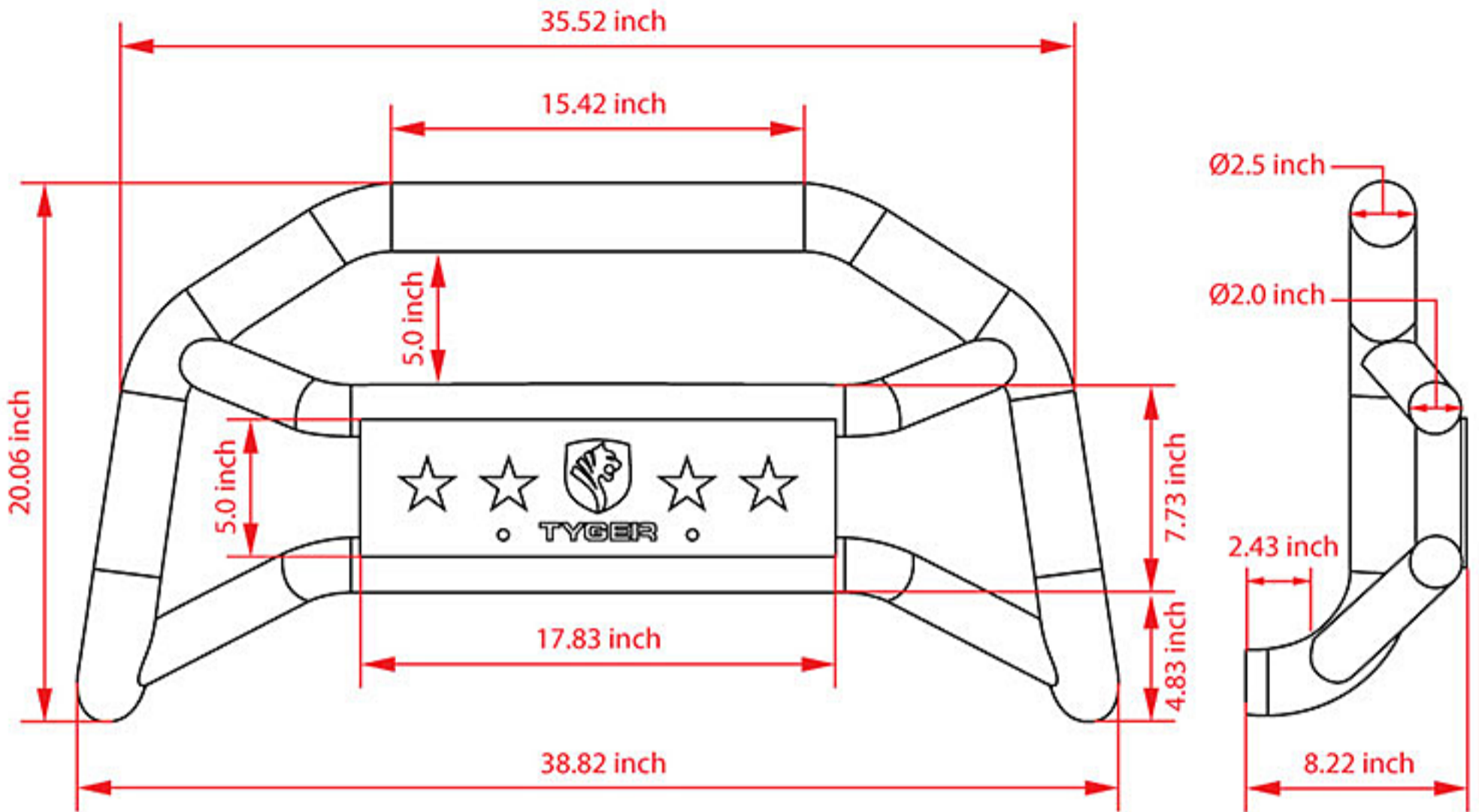

**All mounting hardware and DIY instruction included.**



## Pre-welded channel for light mounting.

(Lights NOT included.)



TG-GD2U28888

Pre-welded light mount channel behind the middle cross bar for LED lights up to 18inch in width. For the 20inch LED light bar, you may need extra bracket #TG-GD2U27777 to mount on.

For lights over 5inch, you can mount them on the top cross bar with extra TYEGR light clamps TG-GD2U28888 which are sold separately.



**Two pre-drilled holes for license plate relocation, if needed.**

