



TYGER®

FENDER FLARE

TG-FF8T4358



ATTENTION!

PLEASE READ THE INSTRUCTIONS CAREFULLY BEFORE STARTING INSTALLATION. PLEASE FOLLOW THE APPROVED INSTALLATION ACCORDING TO THE WRITTEN INSTRUCTIONS. FAILURE TO DO SO MAY CAUSE DAMAGE TO YOUR VEHICLE AND INVALIDATE THE WARRANTY.



WARNING!

DIRT OR DEBRIS MAY BECOME LODGED BETWEEN FLARES AND VEHICLE'S FENDERS CAUSING SCRATCHING AND PAINT WEAR FROM VEHICLE VIBRATION. TYGER™ IS NOT RESPONSIBLE FOR ANY DAMAGE, AND INSTALLATION IS DONE WITH BUYER'S UNDERSTANDING THAT THIS DAMAGE MAY POTENTIALLY OCCUR.

PRIOR TO INSTALLATION:



CHECK EVERYTHING BEFORE INSTALLATION



USE NON-ABRASIVE SURFACE TO INSTALL



VERIFY FITMENT OF FLARES TO VEHICLE



REMOVE DECALS & MUD FLAPS FIRST



ABRASIVE DETERGENT IS PROHIBITED

SAFETY INFORMATION:



NO AUTOMATIC BRUSH-STYLE WASH



CHECK TIGHTNESS



CHECK CAREFULLY BEFORE DRIVE

ABOUT PAINTING: Painted flares cannot be returned. Test fit before painting. We are not responsible for any costs that may incur if flares were painted without test fitting.

- Clean surface to be painted with a good grade degreaser. Do not use lacquer thinner or any solvent based product.
- Wipe flare surface completely dry with a tack rag prior to paint.
- Application of plastic adhesion promoter for PP plastic as per your paint system manufacturer's recommendations is required.
- Use a high quality enamel or polyurethane automotive paint to paint the flares.
- Not recommend to paint the edge trim, but if desired use a flex additive.

TOOLS FOR EASIER INSTALLATION



Utility Knife



Soft Wiping Cloth



Pry Tool



10mm Socket



Socket Wrench



Electric Drill



5/16" Drill Bit



1/8" Drill Bit



1/2" Wrench



#2 Phillips Driver



Grease Pencil



Work Gloves

HARDWARE KIT INCLUDED

x338



[A] Edge Trim

x31



[B] Torx Bolt

x35



[C] SS Washer

x33



[D] Nylock Nut

x1



[E] T45 Torx Bit

x4



[G] PH Truss Screw

x2



[K] SS Torx Screw

x2



[L] Nylon Retainer

x1



[M] Edge Trim Tool



x1 Driver Side



x1 Driver Side



x1 Passenger Side



x1 Passenger Side

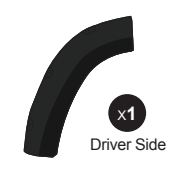

x1 Driver Side

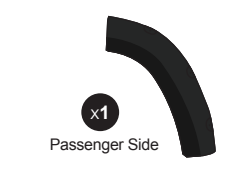

x1 Passenger Side

V200720



EDGE TRIM INSTALLATION

- Peel 2 to 3" of red vinyl backing away from one end of the **Edge Trim [A]** .
- Apply **Edge Trim [A]** over top edge of flare with adhesive side contacting inside edge of flare.
- Press **Edge Trim [A]** into place and apply thumb pressure to ensure good adhesion, pull away red backing as you work your way around flare edge in one-foot increments.

You will need:



Edge Trim [A]

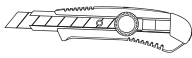

Utility Knife

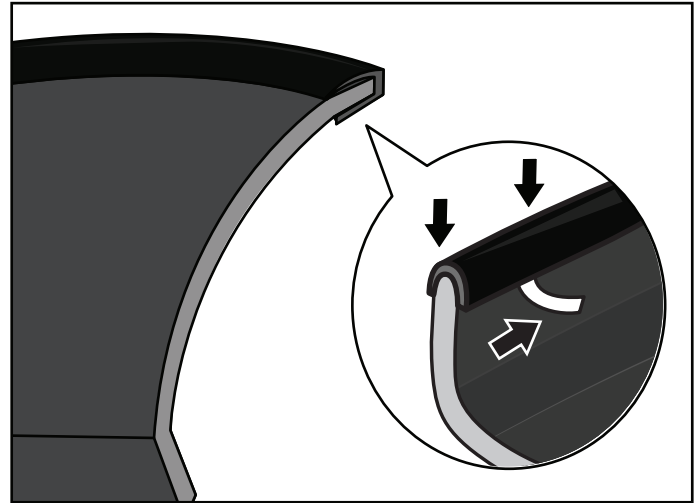

NOTE!

DO NOT stretch Edge Trim during application.

DECORATIVE RIVET INSTALLATION

- Put a **Torx Bolt [B]** with a **Washer [C]** through each of the top holes around the flare and using a **Nylock Nut [D]** to secure on the other side. Using a socket wrench and the supplied **Torx Bit [E]** on an electric drill to tighten bolts. **DO NOT** over-tighten as this may damage the flare.

You will need:



[B]
Torx Bolt



[C]
SS Washer



[D]
Nylock Nut



[E]
T45 Torx Bit



1/2"
Wrench



Electric Drill

NOTE!

- **DO NOT** drill holes on the vehicle body as rivets are decorative and fasten only to the flare. Do not attempt to use the bolts to fasten flare to vehicle body.

- All exposed fasteners and bare metal should be treated with rust resistant paint before installing flares, Spray inner fender wells with undercoating after flare installation

- For vehicle with large tires may require lowering bump stops and/or installing steering stops to prevent tire from contacting flares

- Modification may be necessary to maintain a minimum 4" clearance between flares and exhaust pipes. (Exhaust gases should not vent directly onto flares)

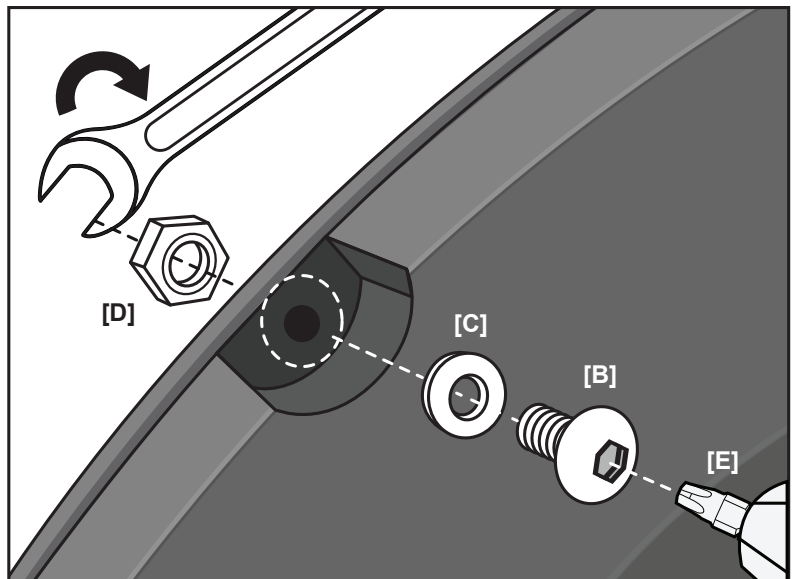



TYGER[®]

FRONT FLARES INSTALLATION



NOTE!

PLEASE USE APPROPRIATE TOOLS TO CLEAN THE VEHICLE IF IT IS NECESSARY, DRY IT OUT BEFORE YOU START THE INSTALLATION.



ATTENTION!

SOME COMPONENTS MIGHT BE SHARP, FOR SAFETY CONCERNS, PLEASE WEAR GLOVES DURING THE INSTALLATION FOR PROTECTION IF IT IS NEEDED.

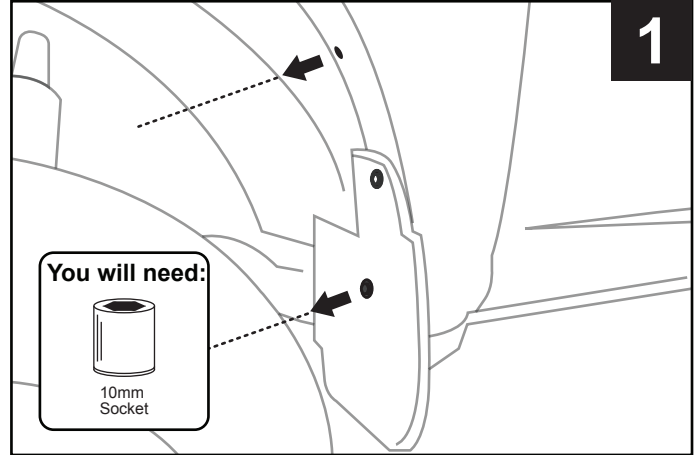

1. Using a 10mm socket, remove two factory screws located at the rear of the wheel well. Retain screws for reinstallation. **NOTE: Flare are meant to be installed with Factory Mud Flaps. DO NOT remove mud flap.**

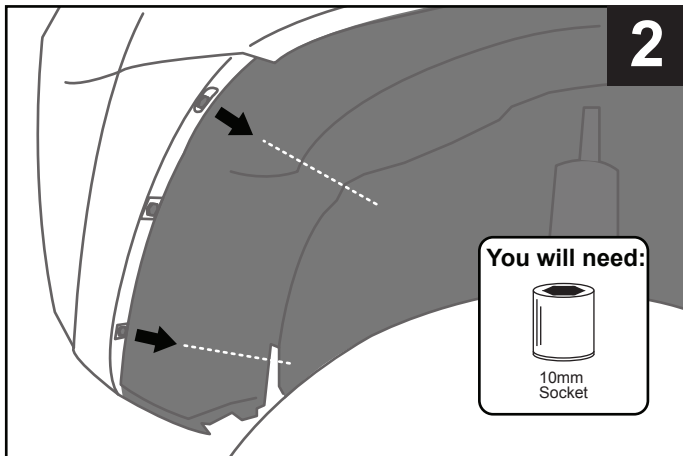

2. Using a 10mm socket, remove two factory fasteners located at front of wheel well. Retain screws for reinstallation.

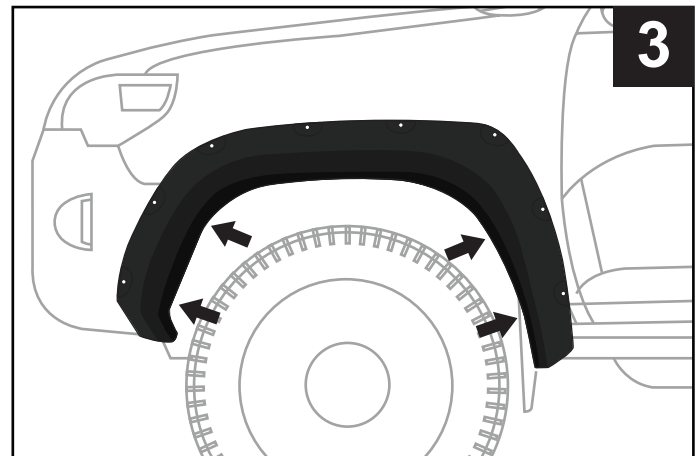

3. Position Front Flare on Fender temporarily. Reinstall factory screws through flare and into hole locations shown. **Note: Make sure the smaller diameter screw is re-installed into the same hole.** Tighten all factory screws.

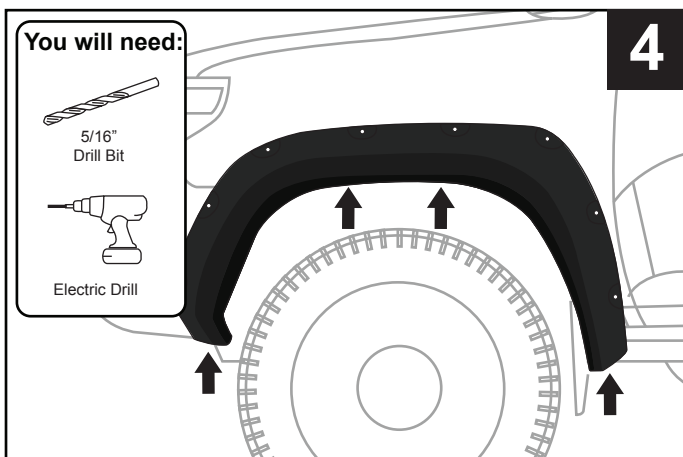

4. Using a 5/16" bit, drill through holes located at the top center, bottom front and rear of the flare into the plastic where indicated.

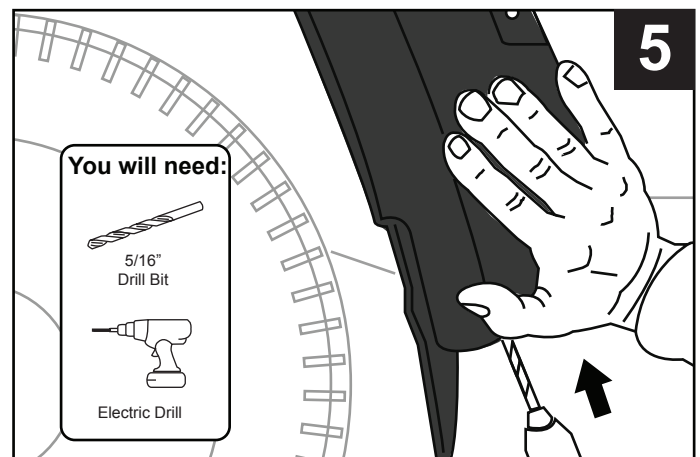

5. **Note: When drilling the bottom rear hole of the front flare, push the flare forward and in towards the wheel well.**



TYGER[®]

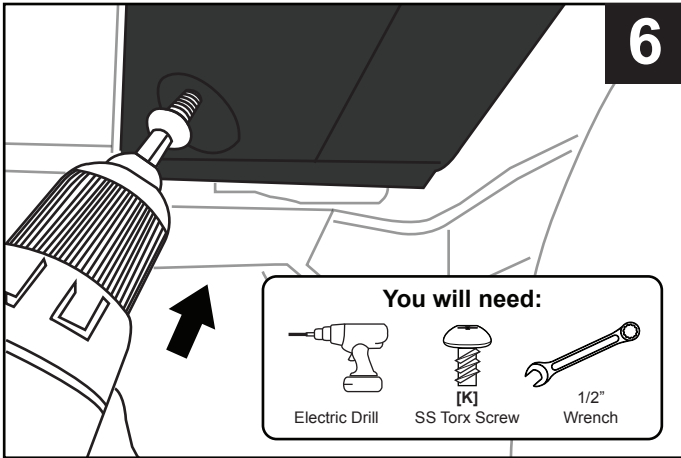

6. Install supplied bolt with one washer in bottom front hole of flare. Install an additional washer and nylock nut from backside of bumper cover, Tighten with 1/2" wrench.

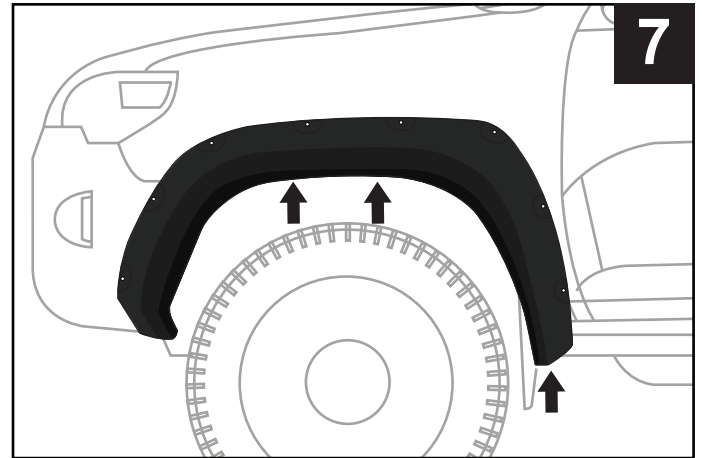

7. Install supplied push retainer into the remaining three holes drilled in the STEP 4. Ensure flare is positioned properly, then apply inward pressure on the flare at each hole location while tightening each screw.



8. Installation Complete. Repeat process for other side of vehicle.

REAR MAIN FLARES INSTALLATION

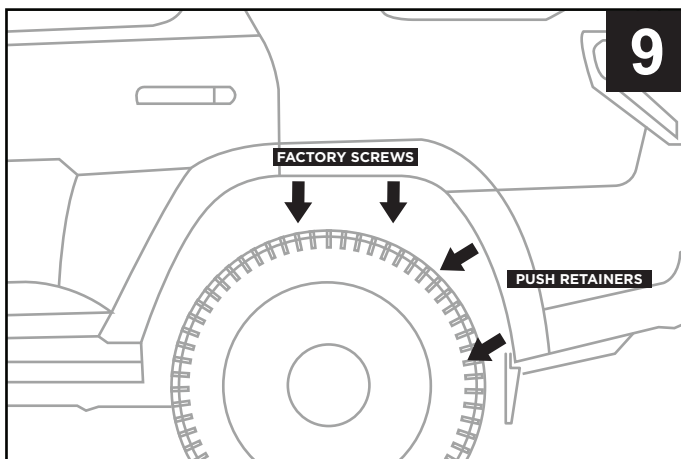

9. Remove two factory screws and two factory push retainers from the Rear Main Flare ONLY. Retain screws for reinstallation.

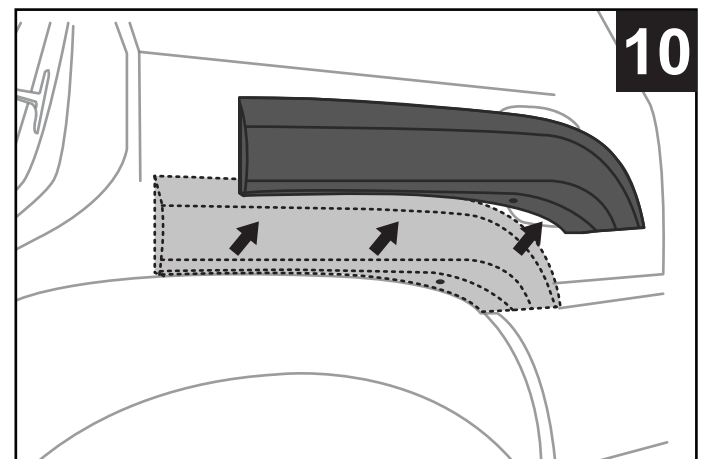

10. Remove factory Rear Main Flare by pulling the part away from the clips on both ends of the part, then grasp in the wheel well and pull off.

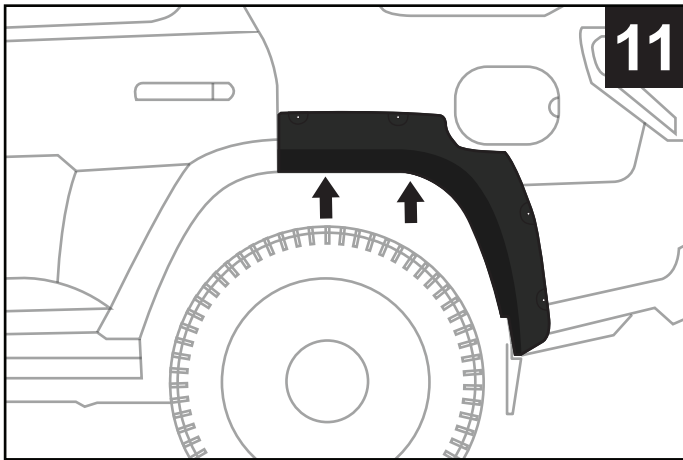

11. Position Flare and hand start two factory screws into the top two holes in flare. Ensure flare is positioned properly, then apply inward pressure on the flare at each hole location while tightening each screw. NOTE: Tighten screw at the

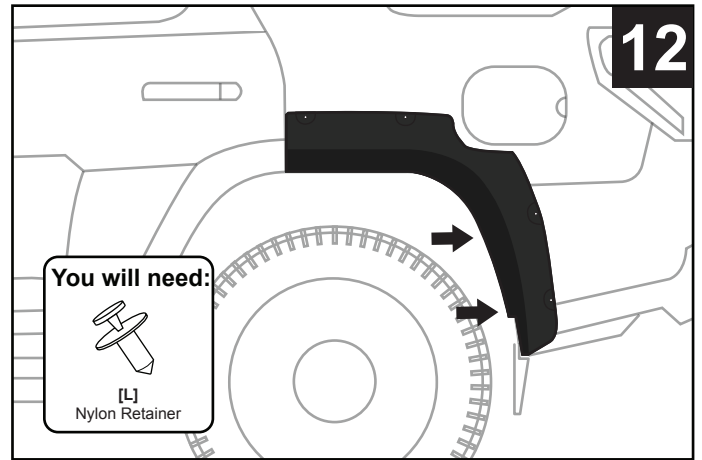

12. Install supplied push retainers in the two lower holes in the flare.

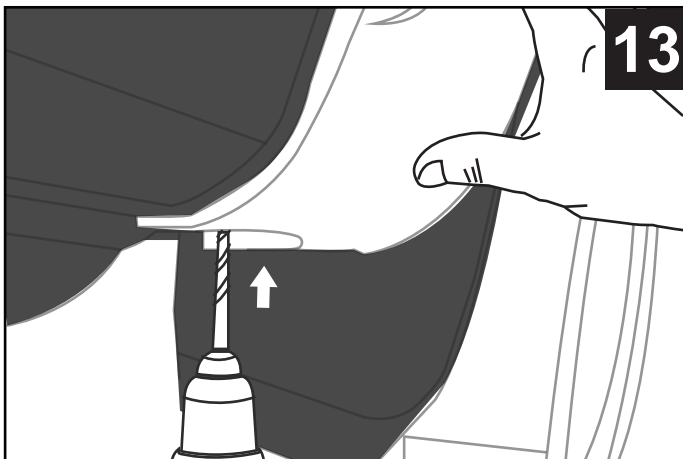

13. Drill a 5/16" hole in the lower rear hole location. NOTE: Press inward on the flare when drilling to ensure proper hole location.

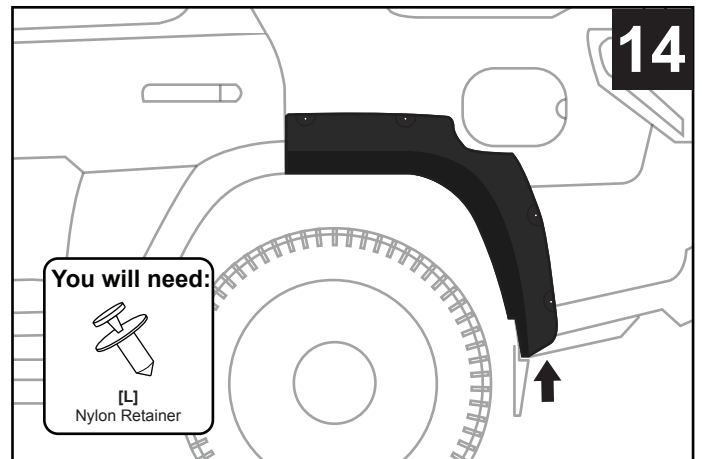

14. Install supplied push retainers in the two lower rear hole.

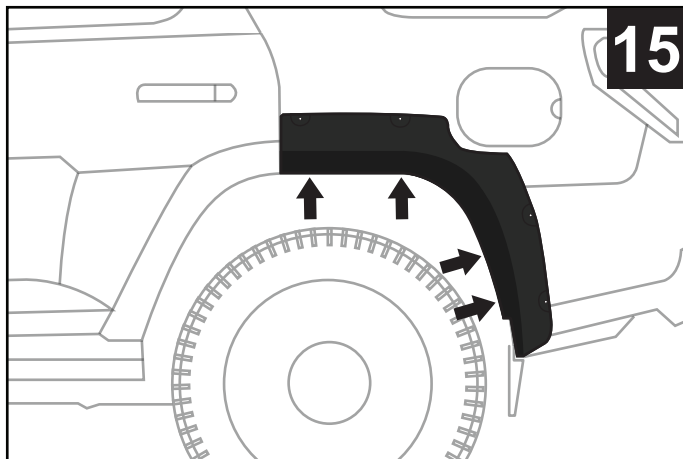

15. Ensure flare is positioned properly, then apply inward pressure on the flare at each hole location while tightening each screw.



REAR DOOR PIECE INSTALLATION

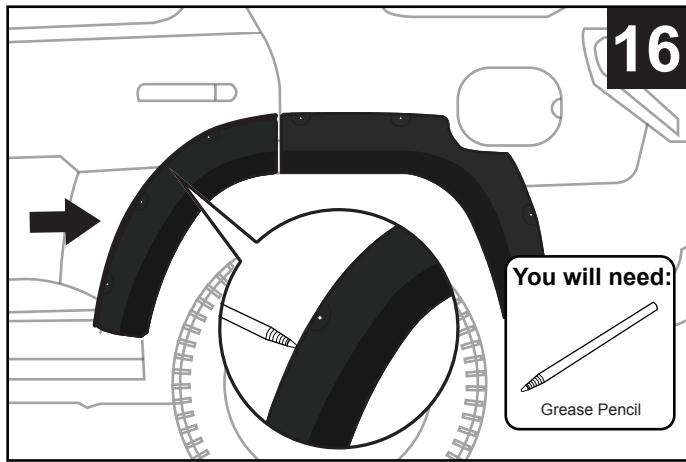

16. Before installing door piece over the factory flare, hold flare in position on the door and dry fit. Using a Grease Pencil, draw a line along the outer edge of the door piece onto the door to make it easier to line up when installing.

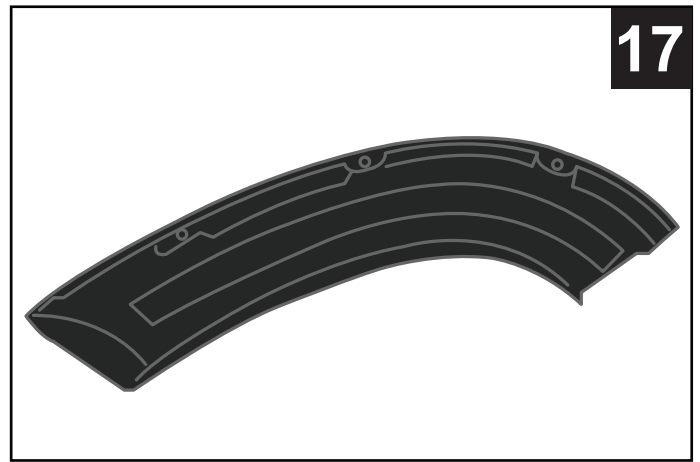

17. Remove tape liner from all tape on back of door piece.

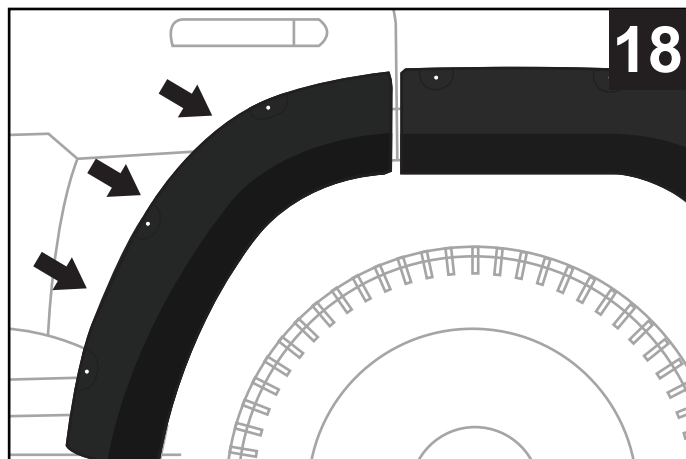

18. Use the line drawn in STEP 16 as a guide. Align door piece with edge of door and carefully press into position on the door over the factory flare. **NOTE: You cannot remove the door piece once it has stuck to the vehicle.**

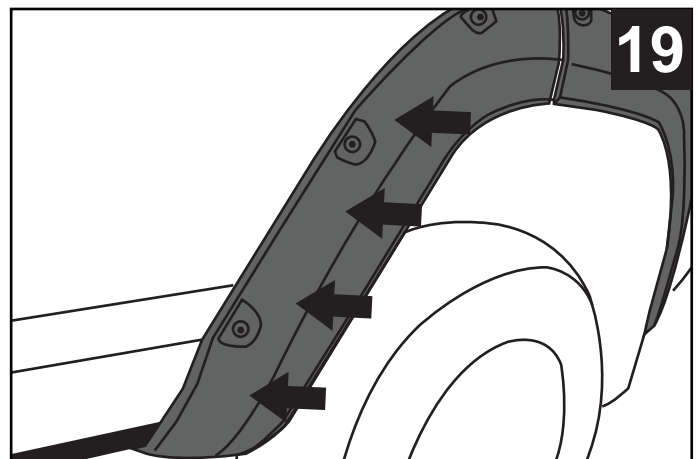

19. Apply pressure along the entire surface of the door piece to ensure all tape is adhered to the vehicle door. Tape reaches maximum adhesive bond after 24 hours of contact.

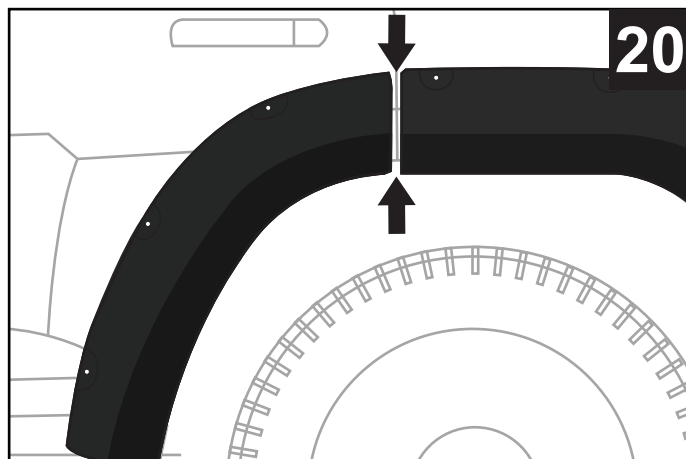

20. Align door piece with rear flare before drilling and installing screws.

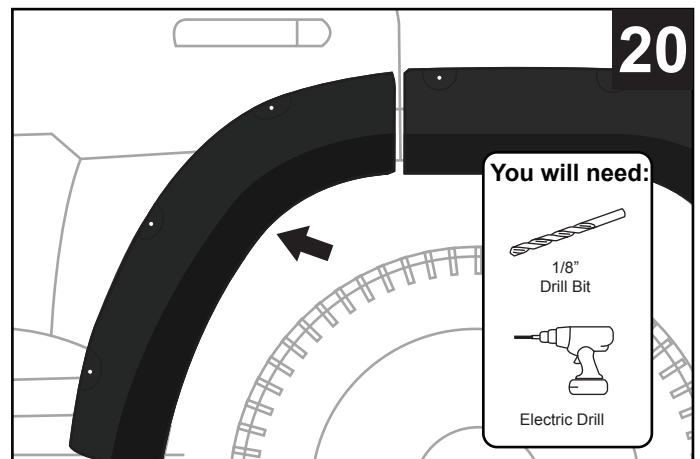

20. Hold top of flare and drill pilot holes in door piece with 1/8" bit.



TYGER[®]

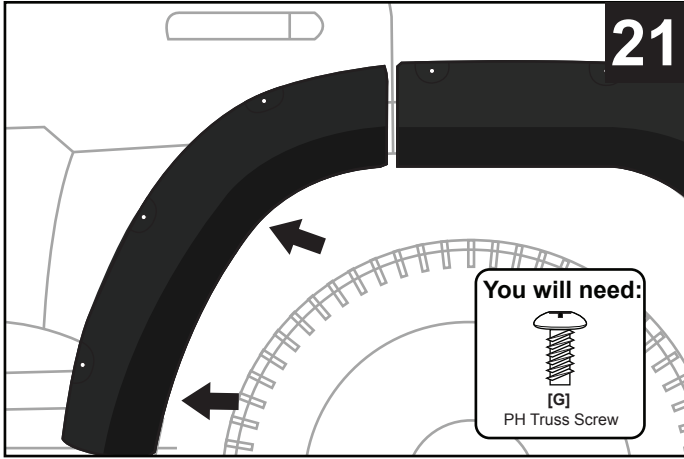

21. Install supplied Truss Head Screws into holes. Screws are attached to factory flare. **DO NOT OVER TIGHTEN SCREWS.**

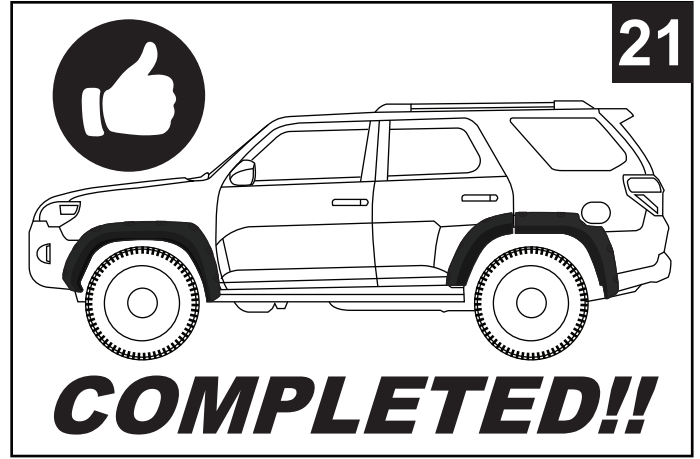

21. Installation Complete.

EDGE TRIM TOOL USAGE (OPTIONAL):

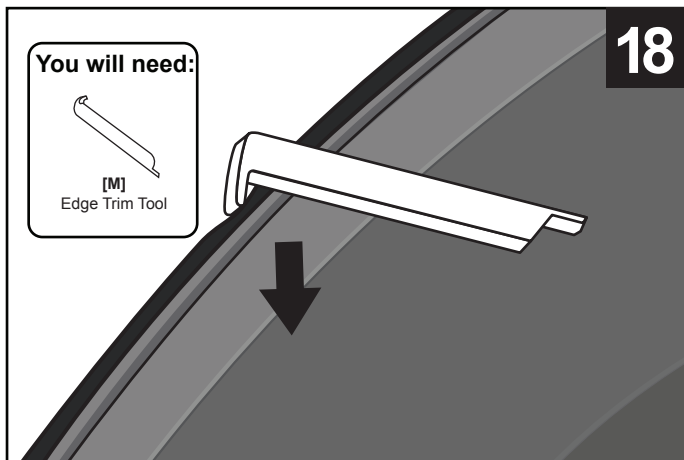

18. If needed, use supplied Edge Trim Tool [M] to trim outer edge by inserting the curved end, then sliding around the entire trim from one end to the other.

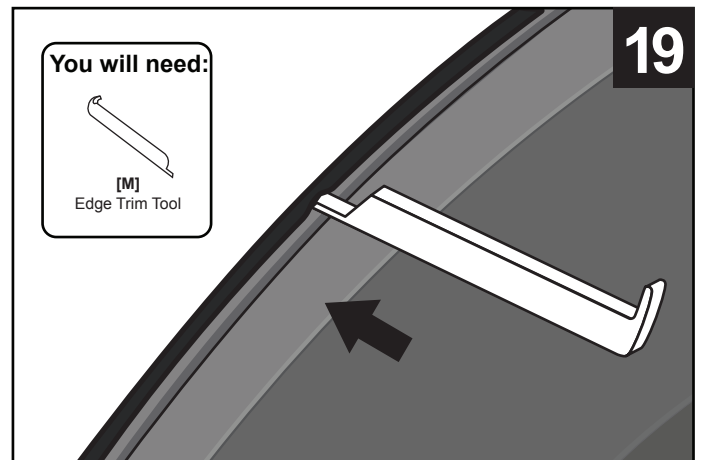

19. If needed, use supplied Edge Trim Tool [M] to trim inner edge by inserting the straight end, then sliding around the entire trim from one end to the other.



TYGER[®]

FITMENT OR GAP ISSUE?

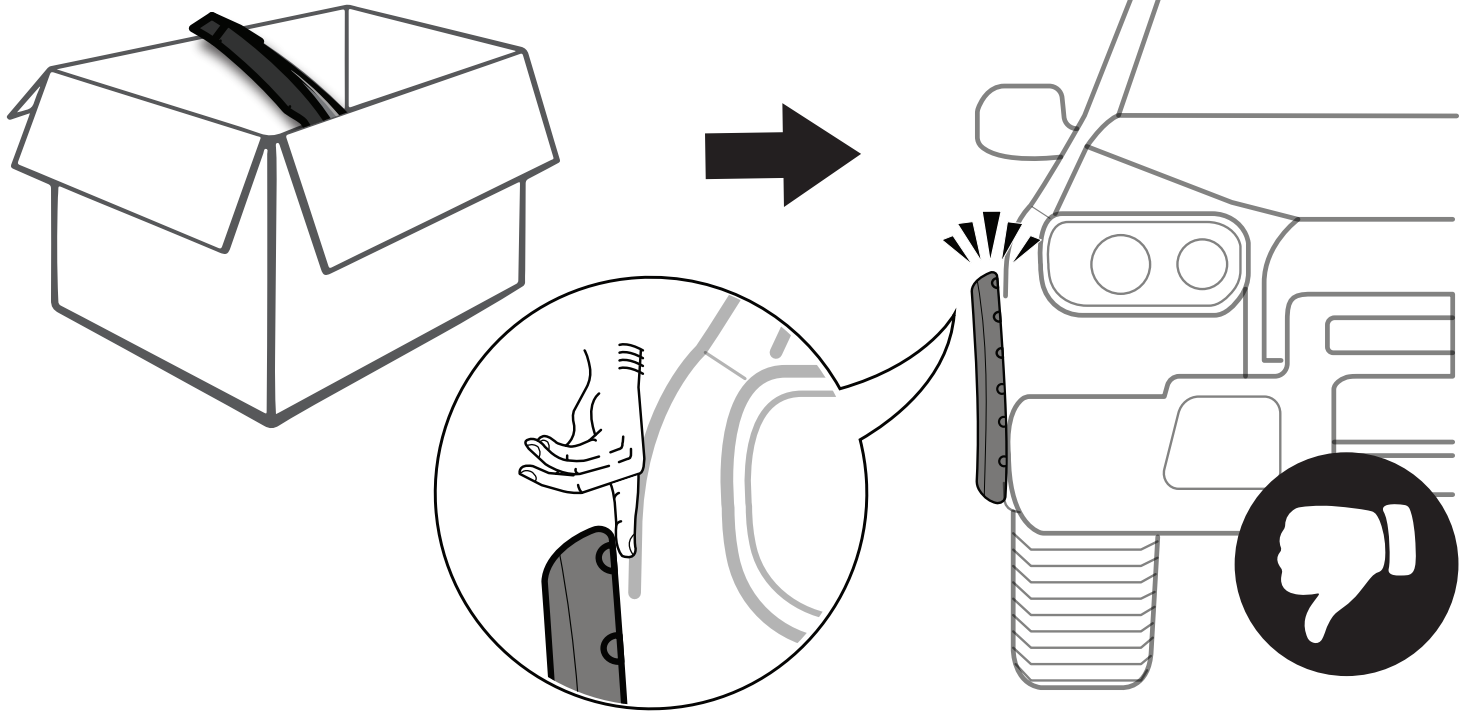

SOLUTION!

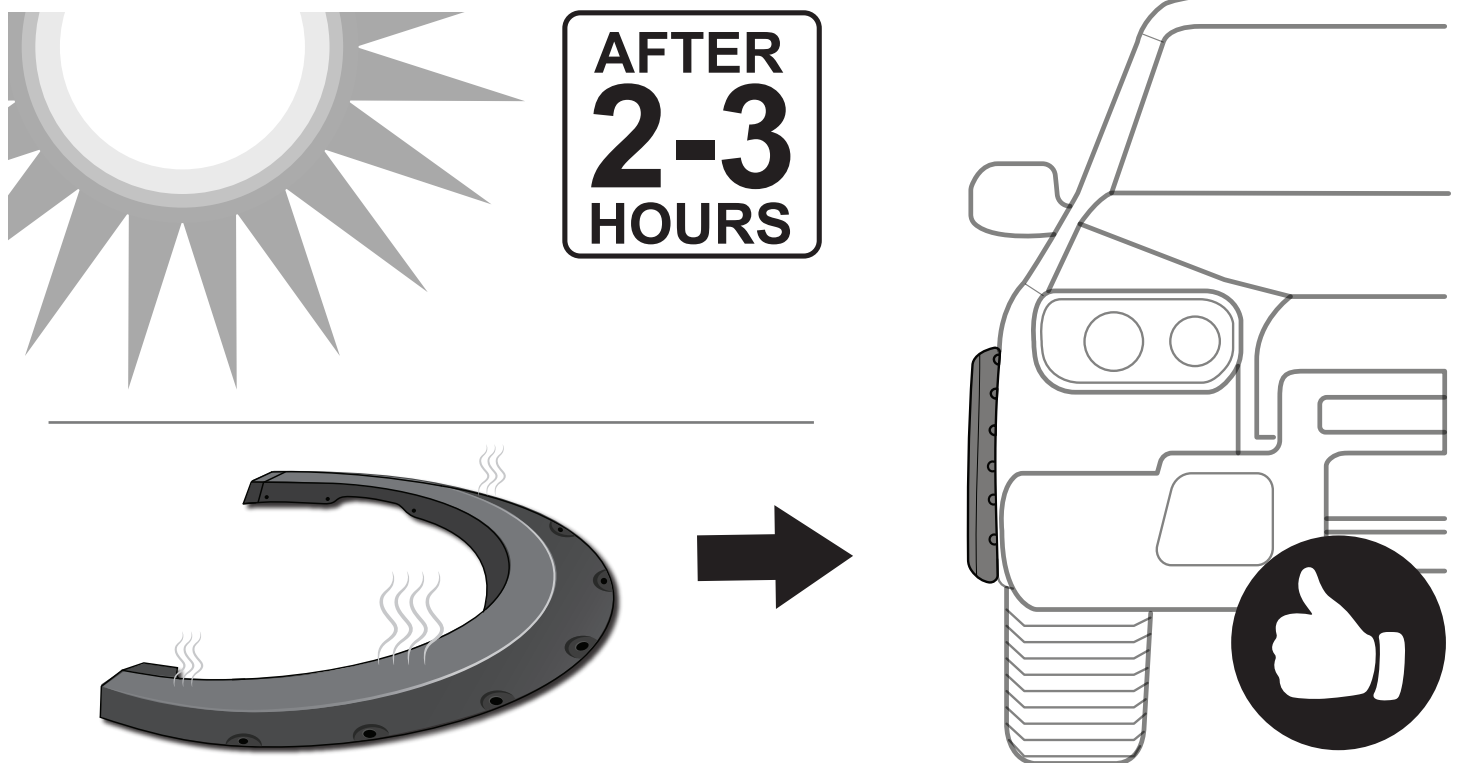

*In winter, heat gun or hair dryer may be used instead.

Discover other fender flares on our website.