



TYGER®

FENDER FLARE

TG-FF8G4158

READ INSTRUCTIONS CAREFULLY BEFORE STARTING INSTALLATION. ONLY FOLLOW THE APPROVED INSTALLATION ACCORDING TO THESE WRITTEN INSTRUCTIONS. FAILURE TO DO SO MAY CAUSE DAMAGE TO YOUR VEHICLE AND INVALIDATE THE WARRANTY.

PRIOR TO INSTALLATION:

- Remove contents from box. Verify all parts are present and free from any defects or damage.
- Make sure installation is done on a non-abrasive surface to avoid scratching the flare surface.
- Verify the fit of each flare to the vehicle body to ensure you have the correct flares for your vehicle.
- Remove existing decals and mud flaps on the vehicle that may interfere with flare installation.
- Do not use any harsh abrasive detergent to clean the flare.

PAINTING

Painted flares cannot be returned. Test fit before painting. We are not responsible for any costs that may incur if flares were painted without test fitting.

- Clean surface to be painted with a good grade degreaser. Do not use lacquer thinner or any solvent based product.
- Wipe flare surface completely dry with a tack rag prior to paint.
- Application of plastic adhesion promoter for PP plastic as per your paint system manufacturer's recommendations is required.
- Use a high quality enamel or polyurethane automotive paint to paint the flares.
- Not recommend to paint the edge trim, but if desired use a flex additive.

WARNING

Dirt or debris may become lodged between flares and vehicle's fenders causing scratching and paint wear from vehicle vibration. TYGER is not responsible for any damage, and installation is done with buyer's understanding that this damage may potentially occur.

SAFETY INFORMATION

- Before driving, ensure that flare is properly secured to vehicle.
- Do not use automatic "brush-style" car wash.
- Periodically check all components for tightness.

Tools Required



1/2" Wrench



7mm Socket



Pry Tool



#2 PH driver



Grease Pencil



Awl(optional)

Hardware Included



[A]

x1



[B]

x38



[C]

x38



[D]

x38



[E]

x1



[F]

x4



[G]

x12



[H]

x12



[I]

x4



[J]

x12



[K]

x1

V200720

EDGE TRIM INSTALLATION

- Peel 2 inches of red backing away from one end of Edge Trim **[A]** .
- Apply Edge Trim over top edge of flare with adhesive side contacting inside edge of flare.
- Press Edge Trim into place and apply thumb pressure to ensure good adhesion, pull away red backing as you work your way around flare edge in one-foot increments. (Fig 1)

NOTE: Do not stretch Edge Trim during application.

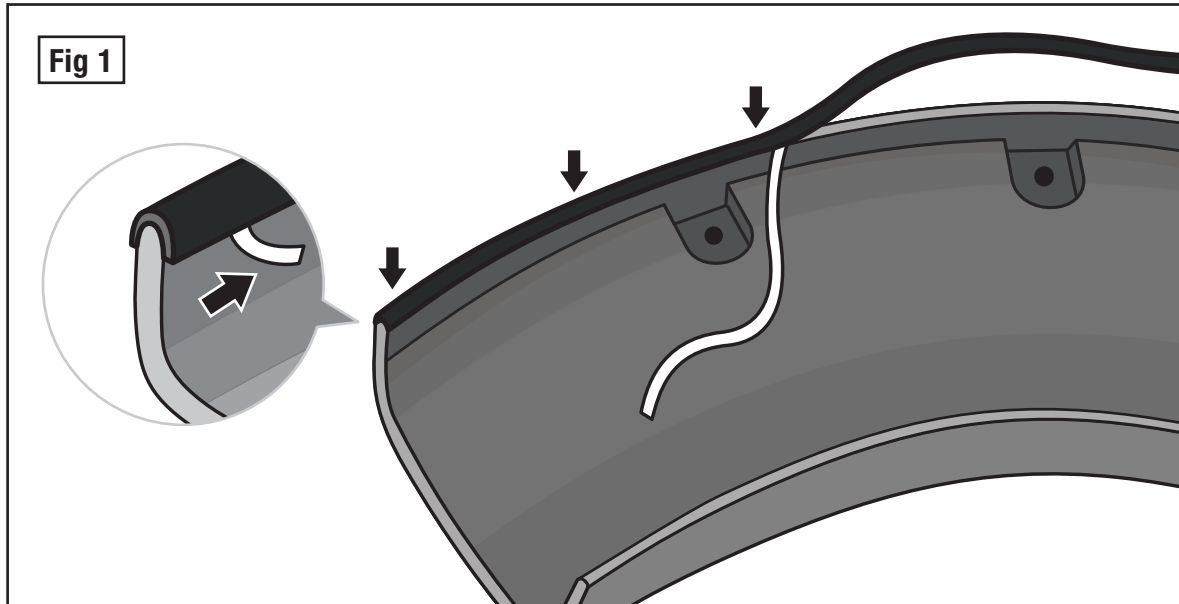

DECORATIVE RIVET INSTALLATION

- Install a Torx Bolt **[B]** with a Washer **[C]** through each of the top holes around the flare and secure using a Nylock Nut **[D]** on the other side. Tighten using a socket wrench and the supplied Torx Bit **[E]**. Do not overtighten as this may damage the flare. (Fig 2)

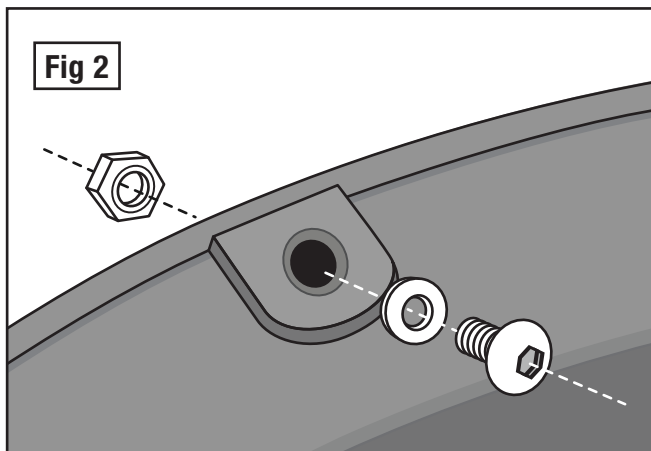

IMPORTANT: Do not drill holes to the vehicle body as rivets are decorative and fasten only to the flare. Do not attempt to use the bolts to fasten flare to vehicle body.

EXTRA NOTES

- All exposed fasteners and bare metal should be treated with rust resistant paint before installing flares. Spray inner fender wells with undercoating after flare installation.
- Modifications may be necessary to maintain a minimum 4" clearance between flares and exhaust pipes. (Exhaust gases should not vent directly onto flares)
- For vehicle with large tires may require lowering bump stops and/or installing steering stops to prevent tire from contacting flare.

Front Driver Side Installation

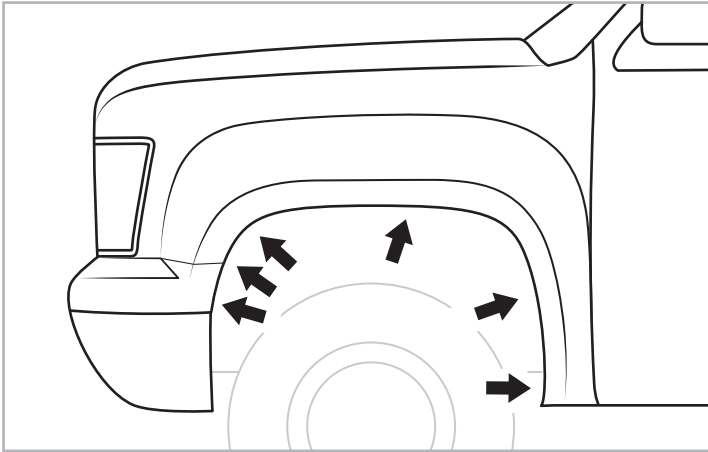

STEP 1: With a 7 mm socket wrench, remove 6 factory screws and keep for later use.

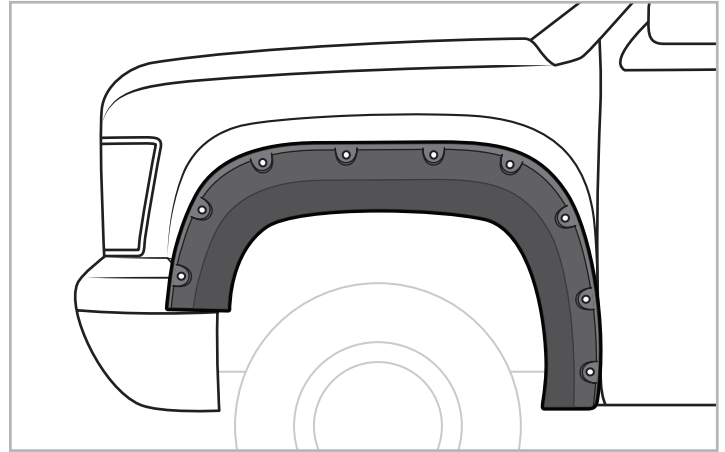

STEP 2: Hold flare in position, reinstall 6 factory screws removed from Step 1 and tighten.

Rear Driver Side Installation

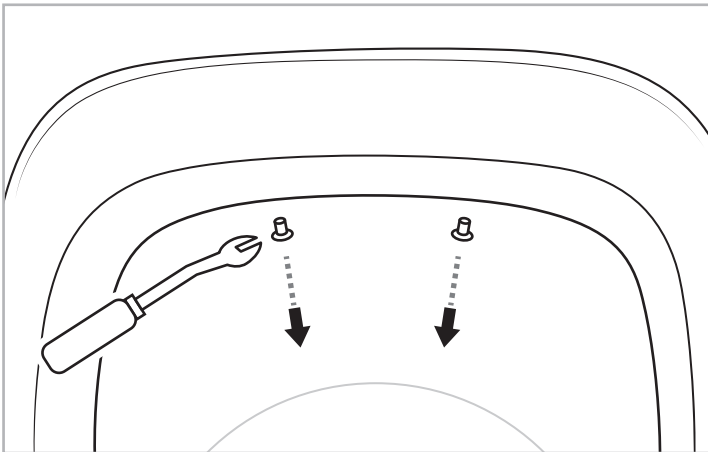

STEP 3: For 2011-2013 models ONLY:
With a pry tool, remove 2 factory tufloks.

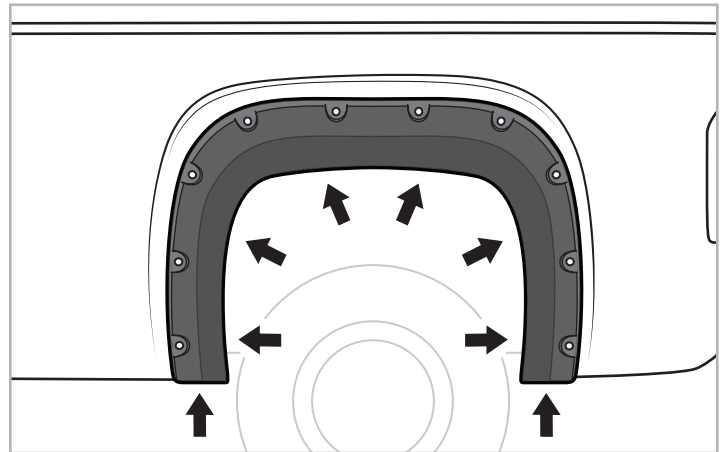

STEP 4: Hold flare in position and push firmly against vehicle. With a grease pencil, mark 8 locations using holes in flare as guide.

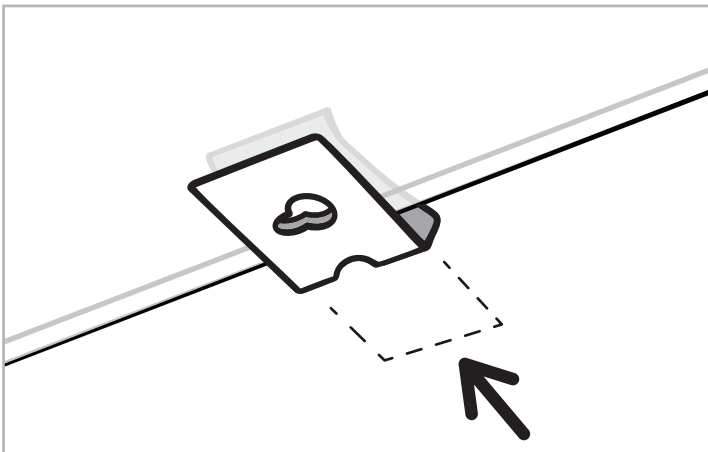

STEP 5: Slide a supplied U-clip [F] over locations indicated in Step 6.

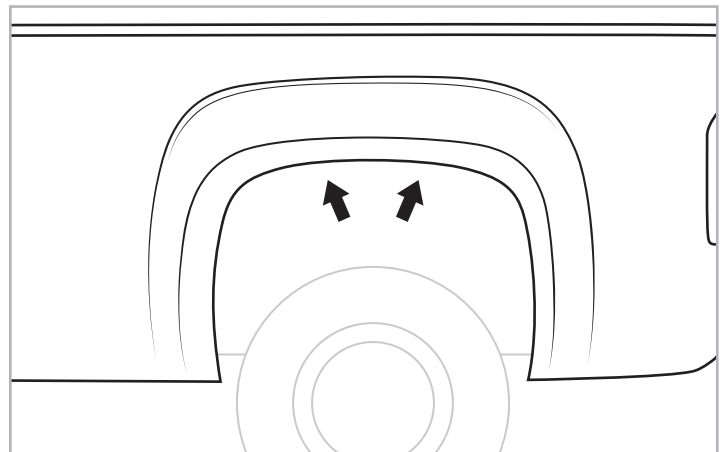

STEP 6: Locations for U-clip installation.

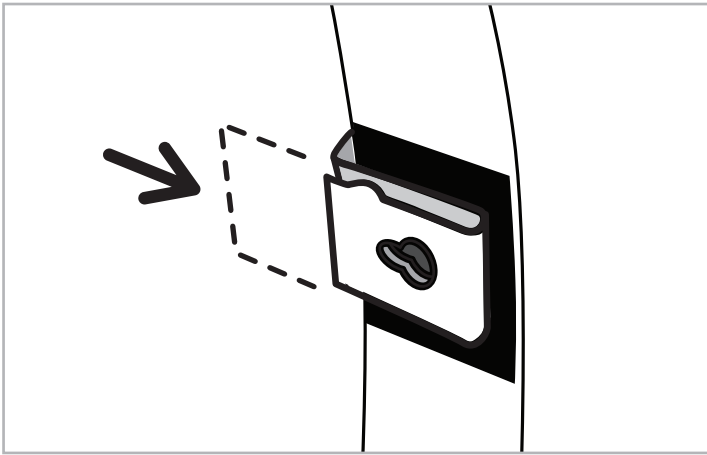

STEP 7: Stick the supplied Tab [G] over remaining marks made in Step 4 by aligning one edge of the Tab with the inside edge of the fender lip. Then, slide the supplied S-clip [H] over each Tab.

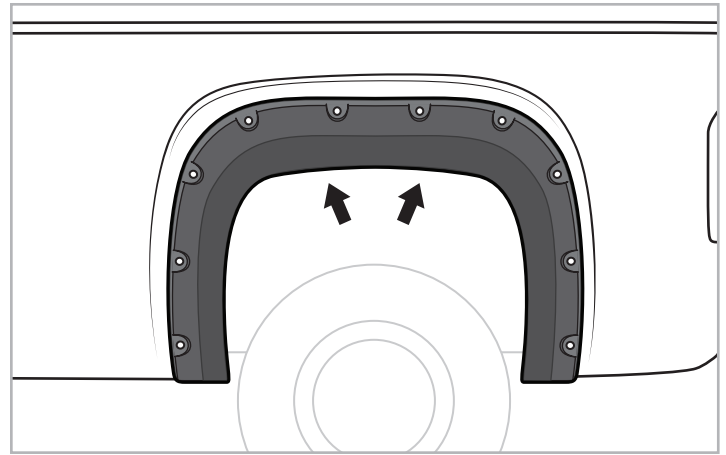

STEP 8: Reposition flare, install 2 supplied PH Truss Screw [I] through top 2 holes in flare and into U-clips installed in Step 5.

NOTE: Awl may be needed to align hole in clip with the hole in flare.

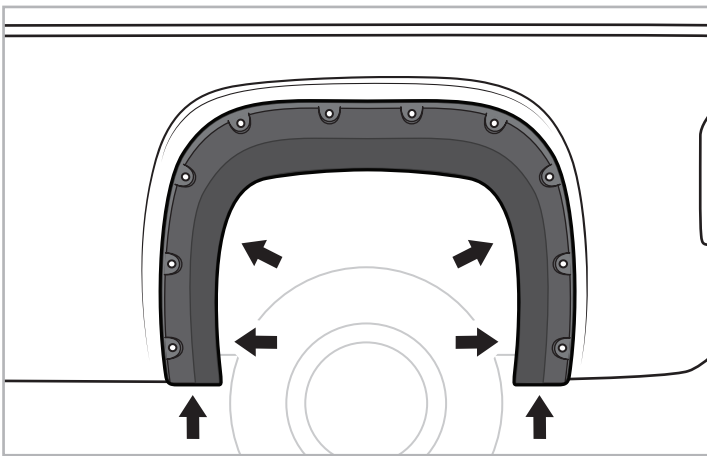

STEP 9: Install 6 supplied PH Metal Screw [J] through remaining holes in flare and into S-clips installed in Step 7.

NOTE: Awl may be needed to align hole in clip with the hole in flare.

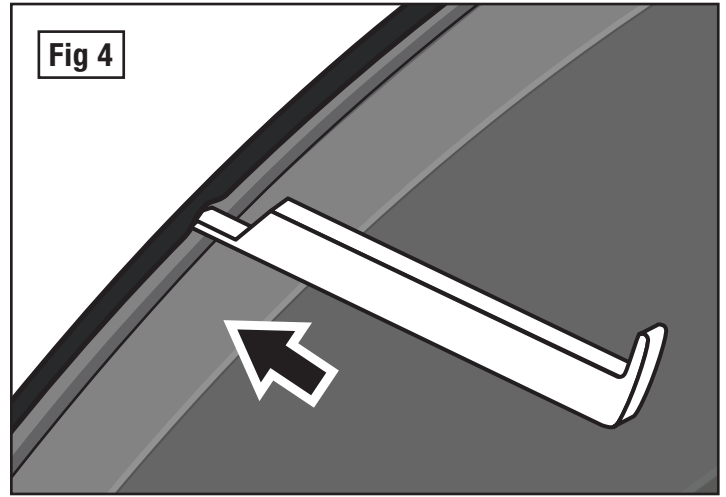
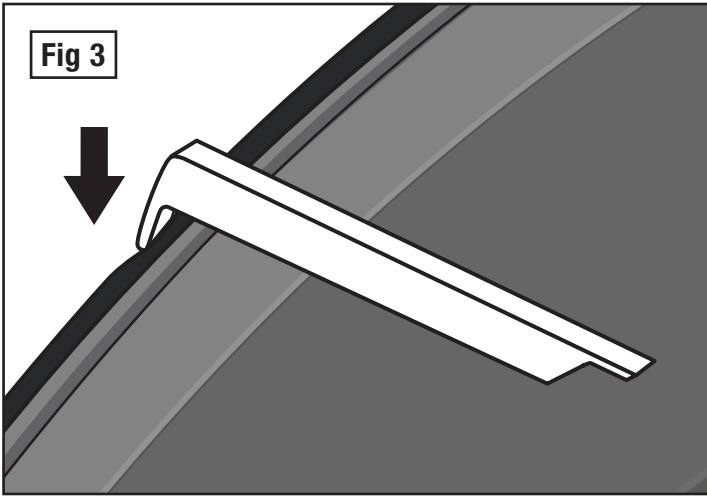

STEP 10: If needed use supplied tool **[K]** to trim outer edge (Fig 3) and inner edge (Fig 4) by inserting tool ends then sliding around the entire edge trims from one end to the other as shown in above pictures.

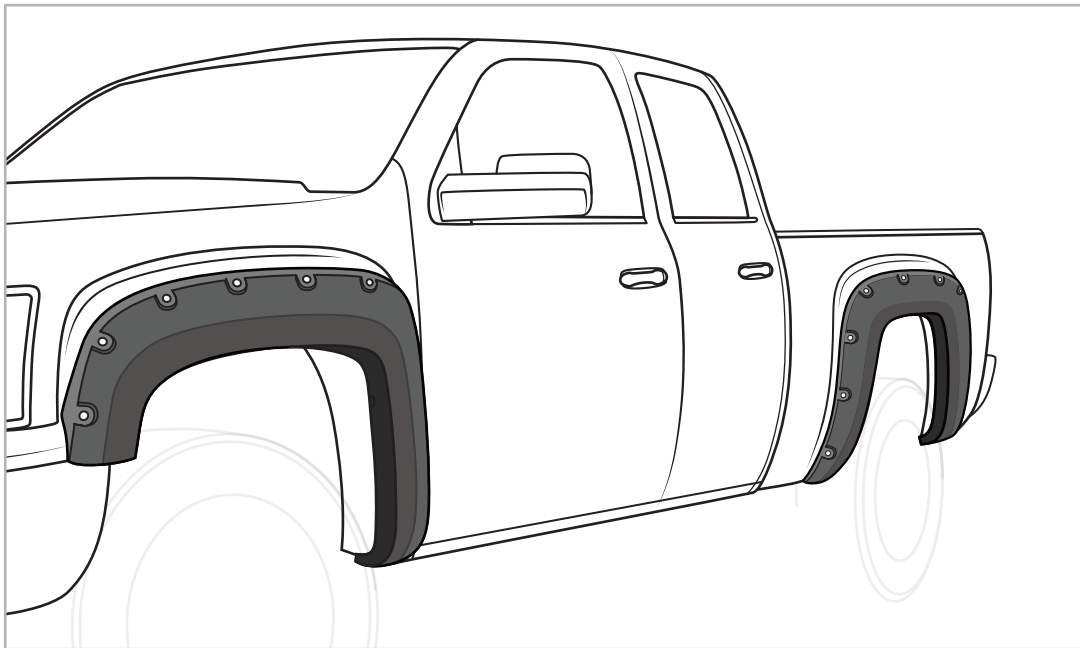

Driver side installation is completed. (Repeat the same steps on passenger side installation.)

FITMENT OR GAP ISSUE?

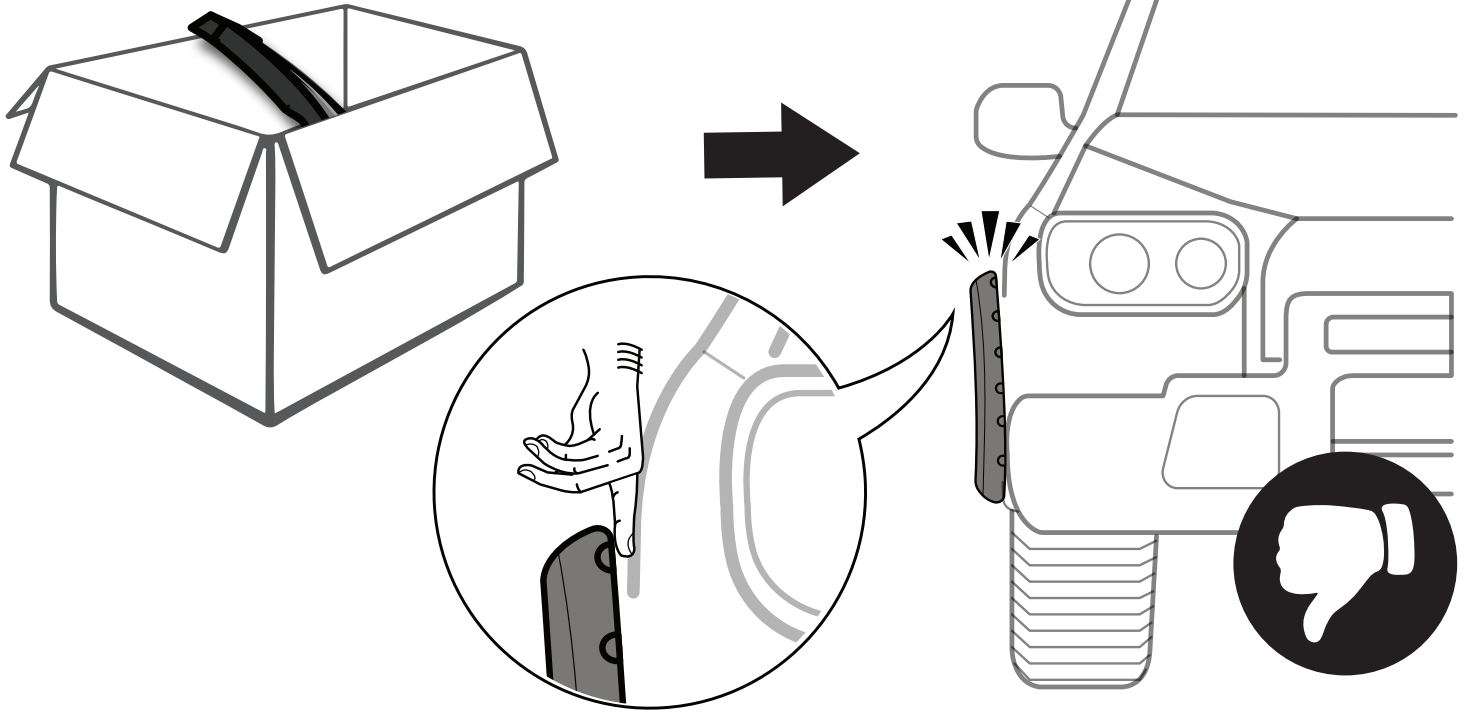

SOLUTION!

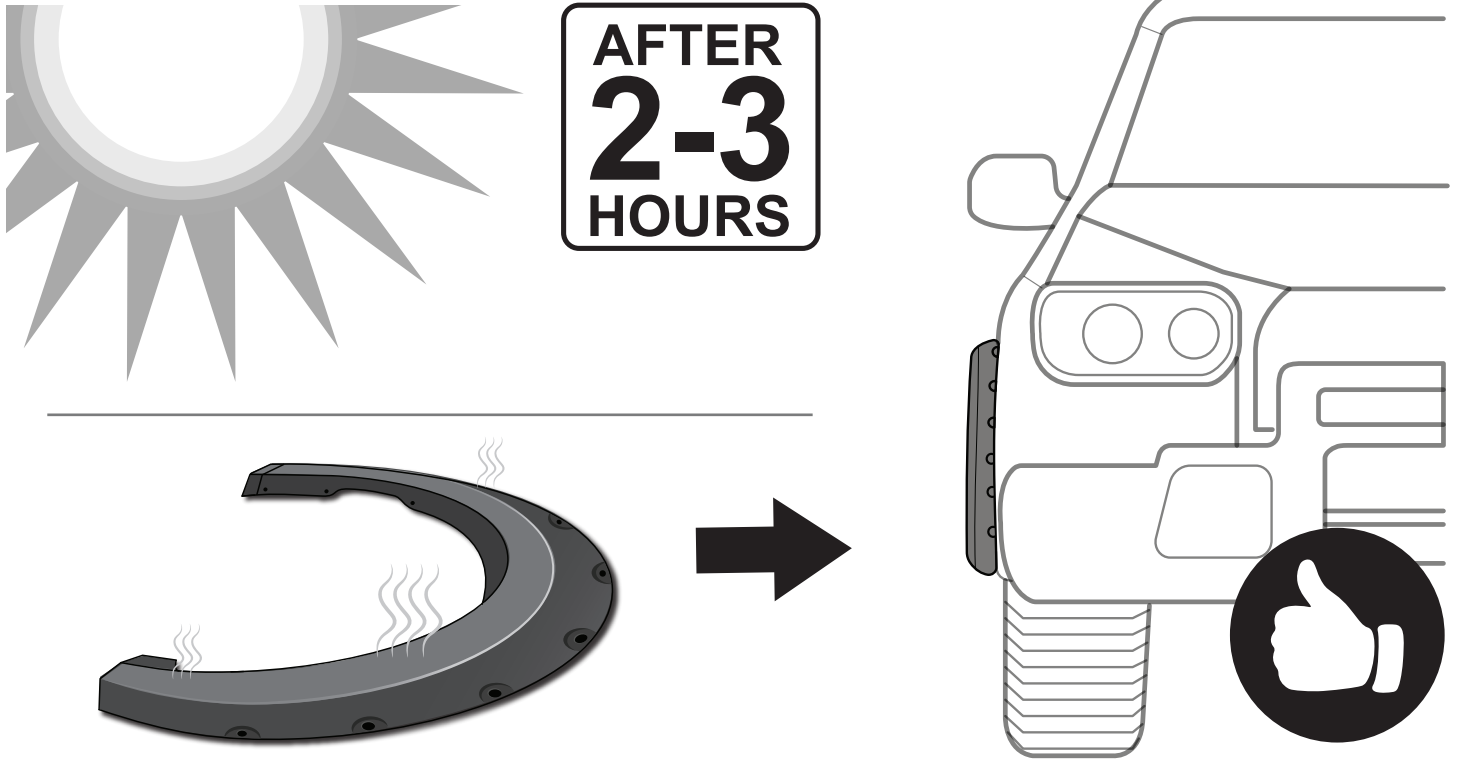

*In winter, heat gun or hair dryer may be used instead.