



TYGER®

FENDER FLARE

TG-FF8F4388



ATTENTION!

PLEASE READ THE INSTRUCTIONS CAREFULLY BEFORE STARTING INSTALLATION. PLEASE FOLLOW THE APPROVED INSTALLATION ACCORDING TO THE WRITTEN INSTRUCTIONS. FAILURE TO DO SO MAY CAUSE DAMAGE TO YOUR VEHICLE AND INVALIDATE THE WARRANTY.



WARNING!

PARTICLES & DIRT STUCK BETWEEN INSTALLED FLARES AND VEHICLE'S FENDERS MAY CAUSE SCRATCHING AND PAINT WEAR FROM VEHICLE VIBRATION. INSTALLATION IS DONE WITH BUYER'S AND/OR USER'S UNDERSTANDING THAT THIS DAMAGE MAY POTENTIALLY OCCUR. TYGER™ IS NOT RESPONSIBLE FOR ANY DAMAGE FROM THIS CAUSE.

PRIOR TO INSTALLATION:



CHECK EVERYTHING BEFORE INSTALLATION



USE NON-ABRASIVE SURFACE TO INSTALL



VERIFY FITMENT OF FLARES TO VEHICLE



REMOVE DECALS & MUD FLAPS FIRST



ABRASIVE DETERGENT IS PROHIBITED

SAFETY INFORMATION:



NO AUTOMATIC BRUSH-STYLE WASH



CHECK TIGHTNESS



CHECK CAREFULLY BEFORE DRIVE

ABOUT PAINTING: Painted flares cannot be returned. Test fit before painting. We are not responsible for any costs that may incur if flares were painted without test fitting.

- Clean surface to be painted with a good grade degreaser. Do not use lacquer thinner or any solvent based product.
- Wipe flare surface completely dry with a tack rag prior to paint.
- Application of plastic adhesion promoter for PP plastic as per your paint system manufacturer's recommendations is required.
- Use a high quality enamel or polyurethane automotive paint to paint the flares.
- Not recommend to paint the edge trim, but if desired use a flex additive.

TOOLS FOR EASIER INSTALLATION



Utility Knife

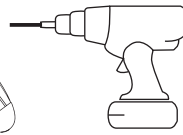

Electric Drill



1/4" Drill Bit



#2 Phillips Driver

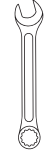

1/2" Wrench



Socket Wrench



7/32" Socket



9/32" Socket



10mm Socket



Grease Pencil

HARDWARE KIT INCLUDED



[A] Edge Trim



[B] Torx Bolt



[C] SS Washer



[D] Nylock Nut

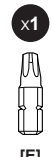

[E] T45 Torx Bit



[F] U-Clip



[G] PH Truss Screw



[H] Mylar Tab



[I] Long U-Clip

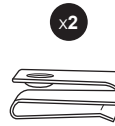

[J] S-Clip



[K] PH Metal Screw



[L] Nylon Retainer

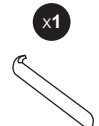

[M] Edge Trim Tool



x2 Inner Bracket



x2 Front Flare



x2 Rear Flare

NOTE:

Driver's side Inner Bracket is marked with "LR", passenger's side Inner Bracket is marked with "RR".

V200720



TYGER[®]

EDGE TRIM INSTALLATION

- Peel 2 to 3" of red vinyl backing away from one end of the **Edge Trim [A]** .
- Apply **Edge Trim [A]** over top edge of flare with adhesive side contacting inside edge of flare.
- Press **Edge Trim [A]** into place and apply thumb pressure to ensure good adhesion, pull away red backing as you work your way around flare edge in one-foot increments.

You will need:



Edge Trim [A]

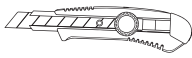

Utility Knife

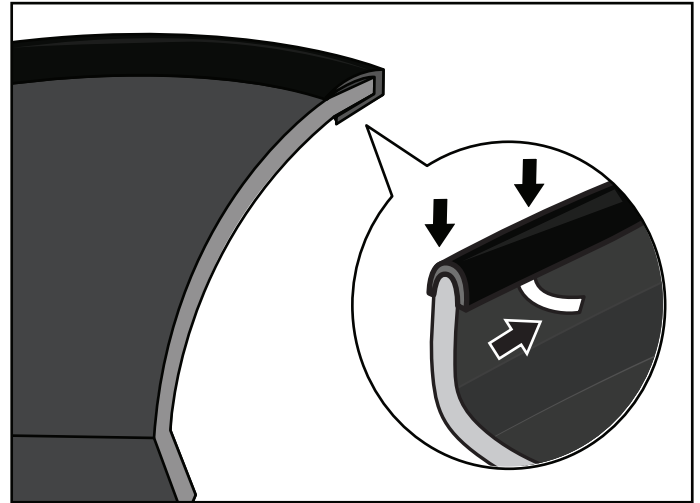

NOTE!

DO NOT stretch Edge Trim during application.

DECORATIVE RIVET INSTALLATION

- Put a **Torx Bolt [B]** with a **Washer [C]** through each of the top holes around the flare and using a **Nylock Nut [D]** to secure on the other side. Using a socket wrench and the supplied **Torx Bit [E]** on an electric drill to tighten bolts. **DO NOT** over-tighten as this may damage the flare.

You will need:



[B]
Torx Bolt



[C]
SS Washer



[D]
Nylock Nut



[E]
T45 Torx Bit



1/2"
Wrench



Electric Drill

NOTE!

- **DO NOT** drill holes on the vehicle body as rivets are decorative and fasten only to the flare. Do not attempt to use the bolts to fasten flare to vehicle body.

- All exposed fasteners and bare metal should be treated with rust resistant paint before installing flares, Spray inner fender wells with undercoating after flare installation

- For vehicle with large tires may require lowering bump stops and/or installing steering stops to prevent tire from contacting flares

- Modification may be necessary to maintain a minimum 4" clearance between flares and exhaust pipes. (Exhaust gases should not vent directly onto flares)

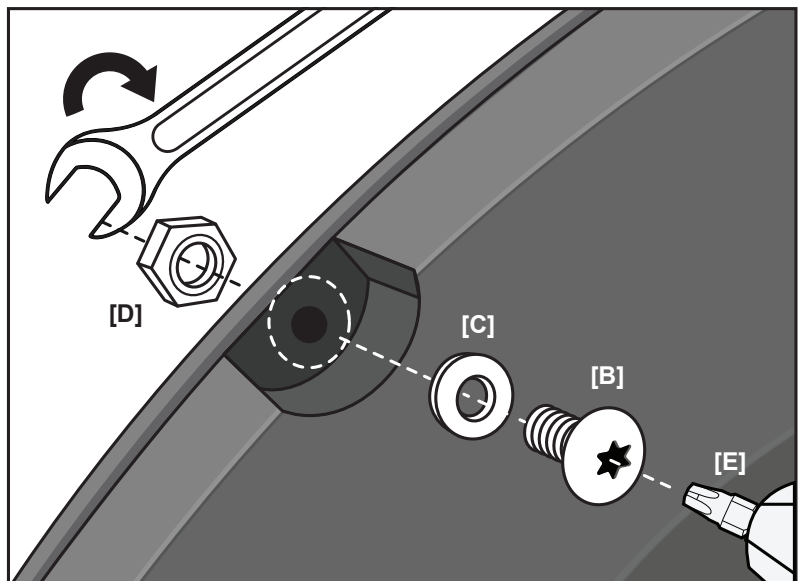



FRONT FLARES INSTALLATION



NOTE!

PLEASE USE APPROPRIATE TOOLS TO CLEAN THE VEHICLE IF IT IS NECESSARY, DRY IT OUT BEFORE YOU START THE INSTALLATION.



ATTENTION!

SOME COMPONENTS MIGHT BE SHARP, FOR SAFETY CONCERNS, PLEASE WEAR GLOVES DURING THE INSTALLATION FOR PROTECTION IF IT IS NEEDED.

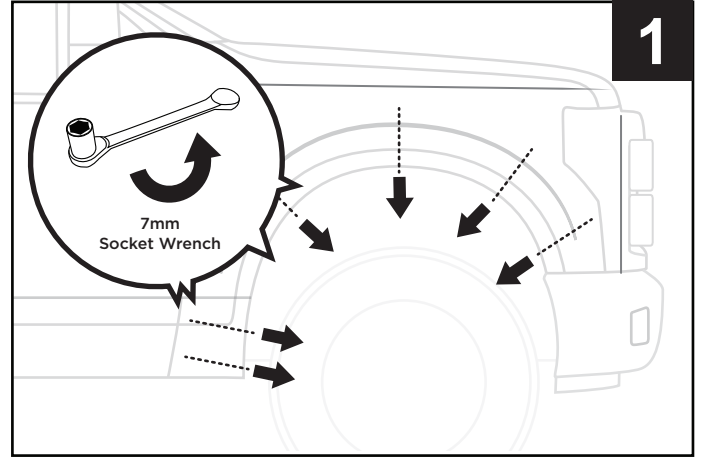

1. Remove and save 6 factory screws for later use.

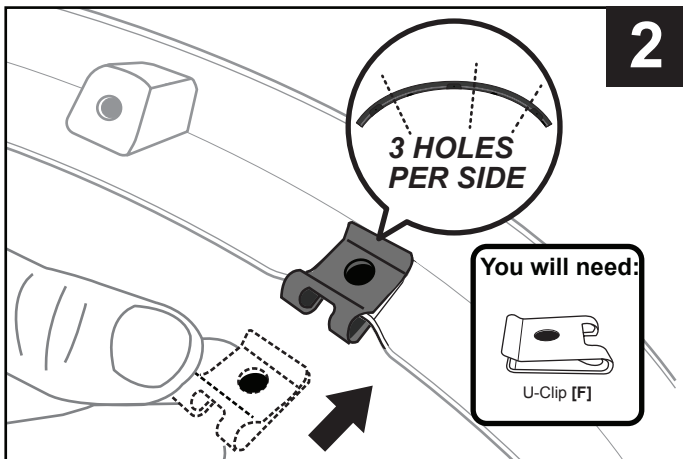

2. For the supplied passenger side inner bracket RR, slide 3 supplied U-Clips [F] to each bracket groove. Ensure clip holes line up with bracket holes.

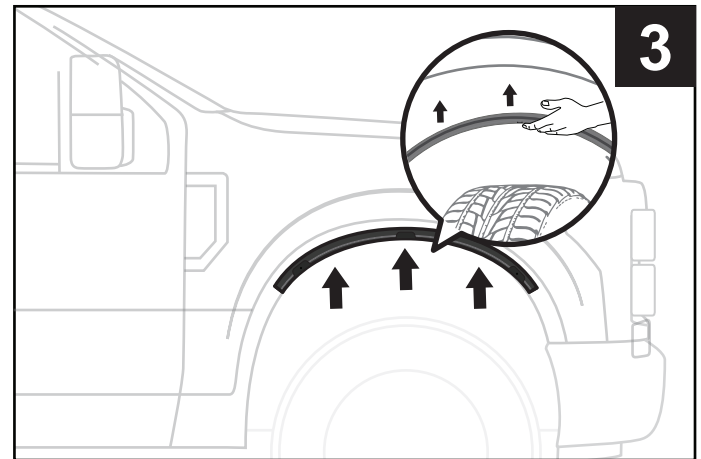

3. Line up holes (with clips) in inner bracket against the 3 uppermost factory holes.

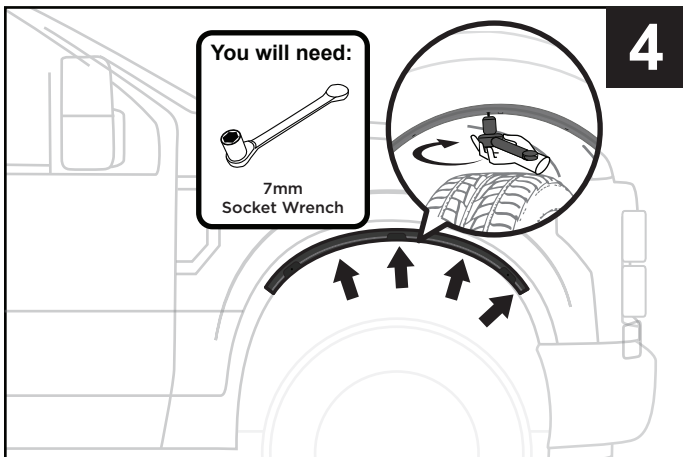

4. Reinstall 4 factory screws to fasten inner bracket through original factory holes from STEP 1.

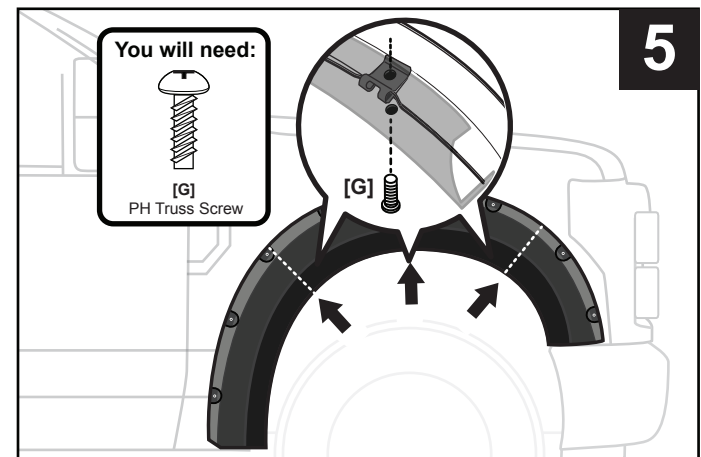

5. Tightly press flare against vehicle to evenly remove space between flare and vehicle by aligning 3 top flare holes to inner bracket clip holes. Then install 3 PH Screws [G] through flare holes into clip holes without tightening



TYGER[®]

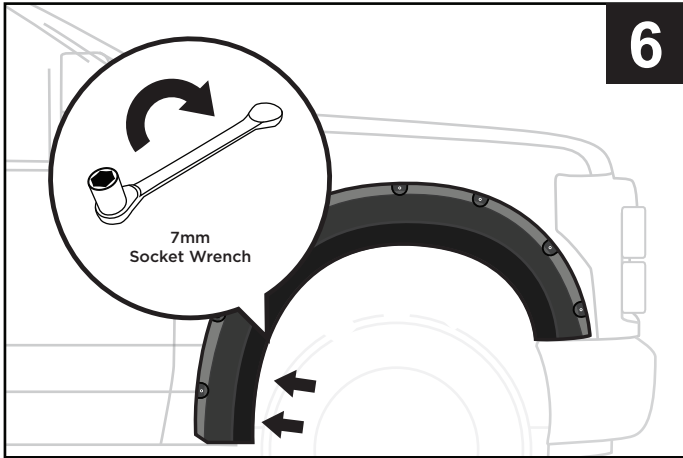

6. Reinstall 2 remaining factory screws to 2 lower factory holes in wheel well.

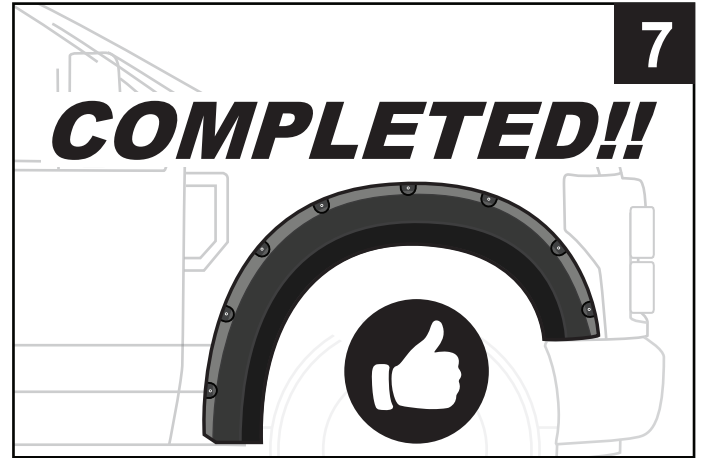

7. Tighten all 5 screws from STEPS 5-6 to complete. Repeat STEPS 1-7 for driver side front flare.

REAR FLARES INSTALLATION

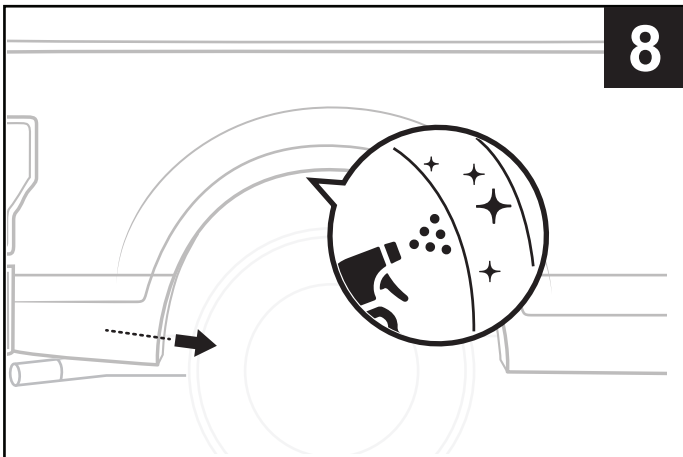

8. Remove factory fastener from rearward end of rear wheel well. If needed, clean installation surface on wheel well.

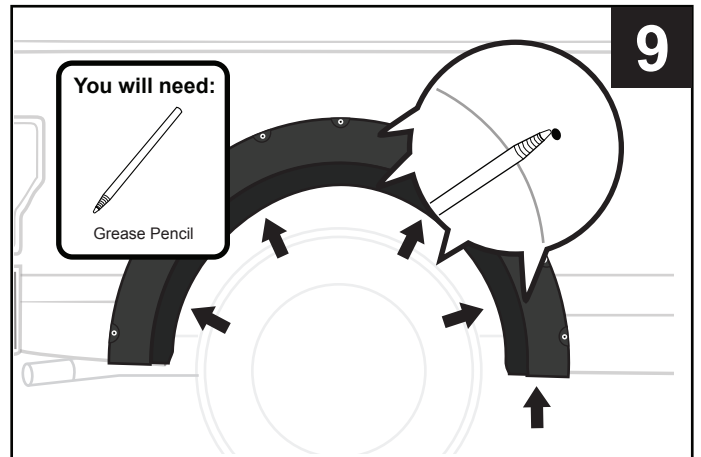

9. Secure flare in position and mark 5 flare hole positions with grease pencil.

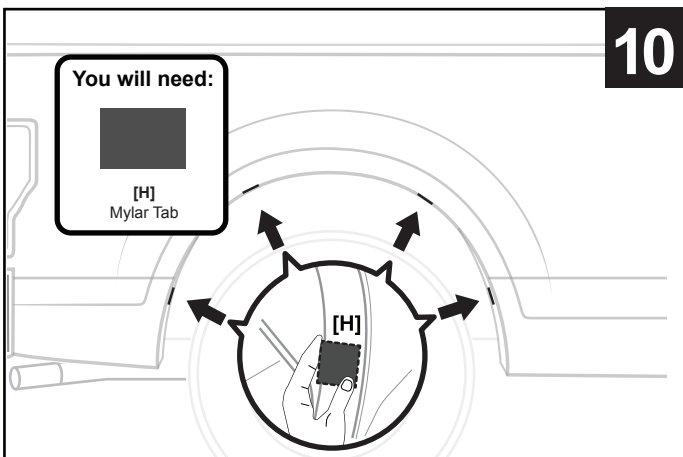

10. Center and apply over each of these 4 marked spots from STEP 9 with a supplied Mylar Tab [H] and wrap excess tab around metal surface.

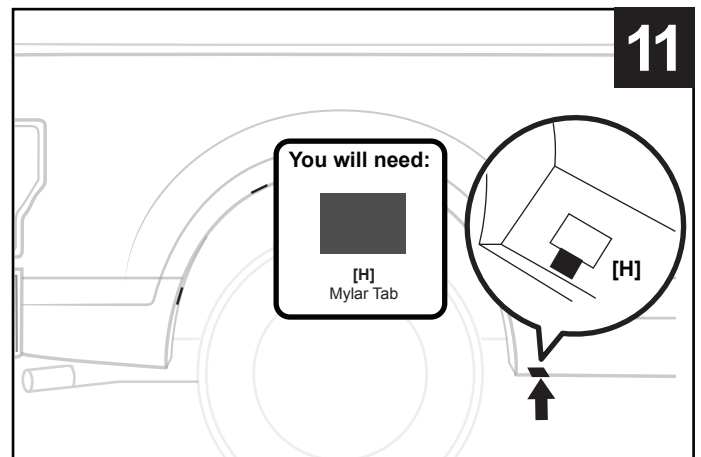

11. Apply another Mylar Tab [H] over 5th marked spot at the bottom.



TYGER[®]

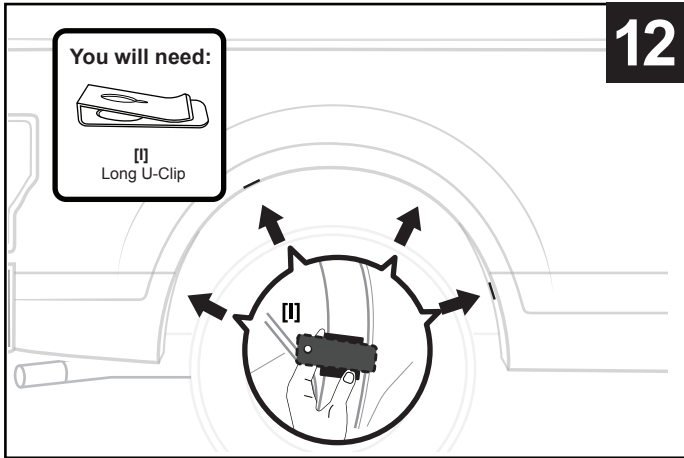

12. Install 4 supplied Long U-Clips [I] over each of the 4 Mylar Tabs installed in STEP 10.

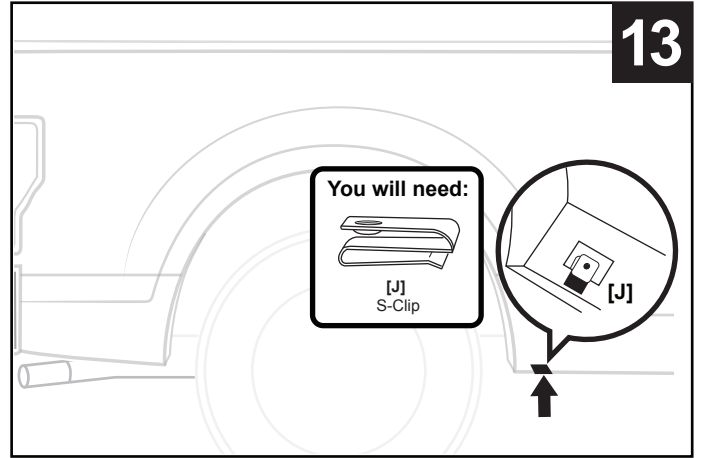

13. Slide supplied S-Clip [J] over applied bottom Mylar Tab from STEP 11.

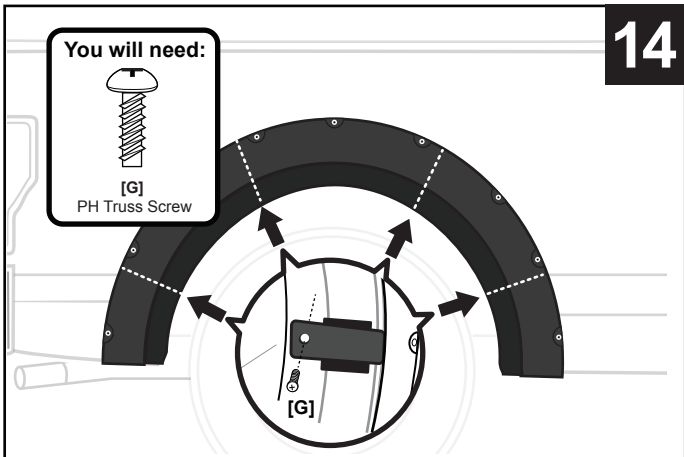

14. Secure flare against vehicle and install 4 supplied PH Truss Screws [G] through top 4 flare holes and into each Long U-Clips.

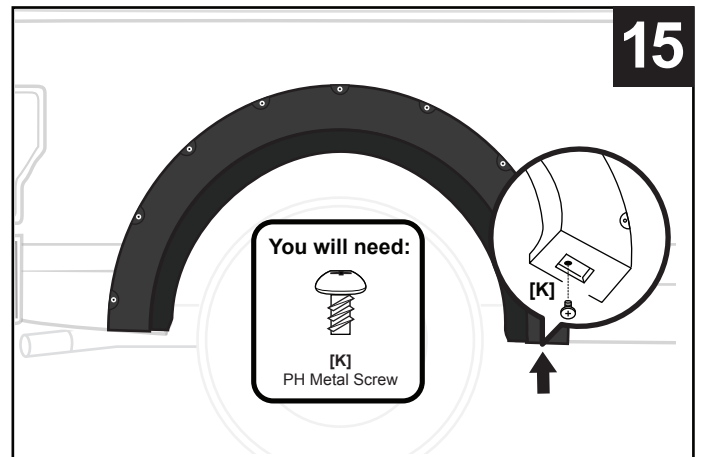

15. Install supplied PH Metal Screw [K] through lower flare hole into the S-Clip.

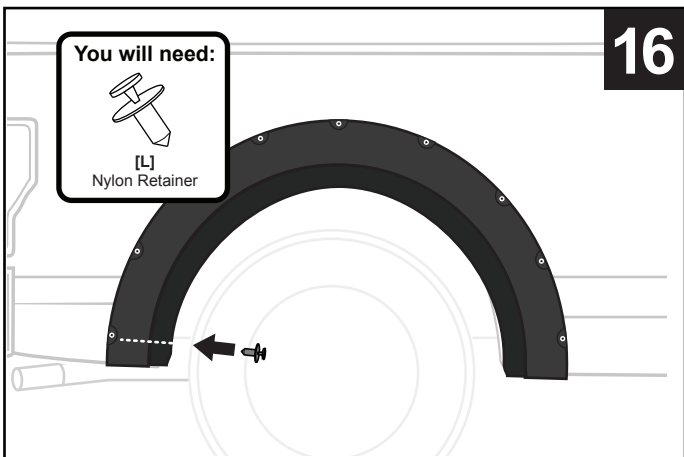

16. Install supplied Nylon Retainer [L] through flare hold and into factory hole left from removed fastener in STEP 8.



17. Tighten all 5 screws from STEPS 14-15 to complete installation. Repeat STEPS 8-17 to the other side.



EDGE TRIM TOOL USAGE (OPTIONAL):

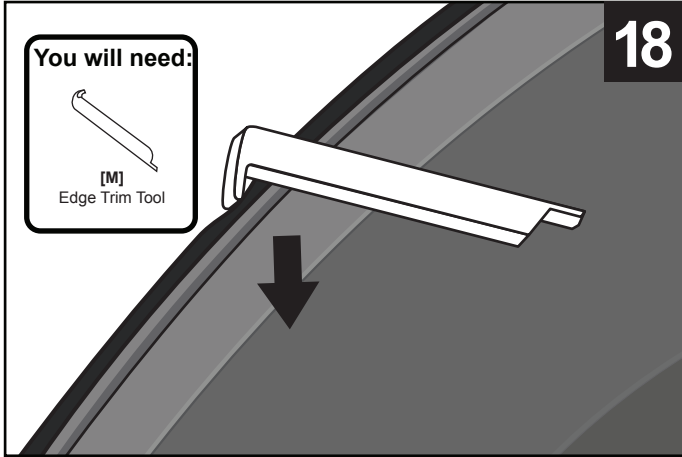

18. If needed, use supplied Edge Trim Tool [M] to trim outer edge by inserting the curved end, then sliding around the entire trim from one end to the other.

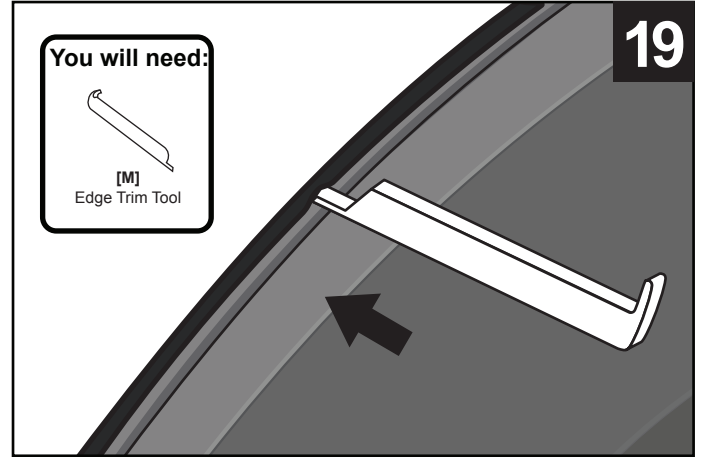

19. If needed, use supplied Edge Trim Tool [M] to trim inner edge by inserting the straight end, then sliding around the entire trim from one end to the other.

FINAL COMPLETED EFFECTS

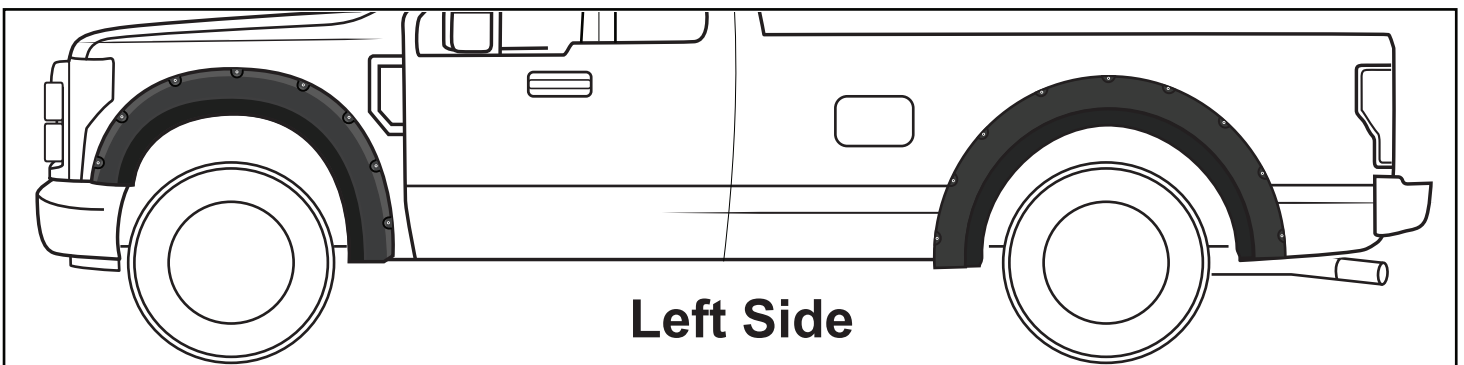
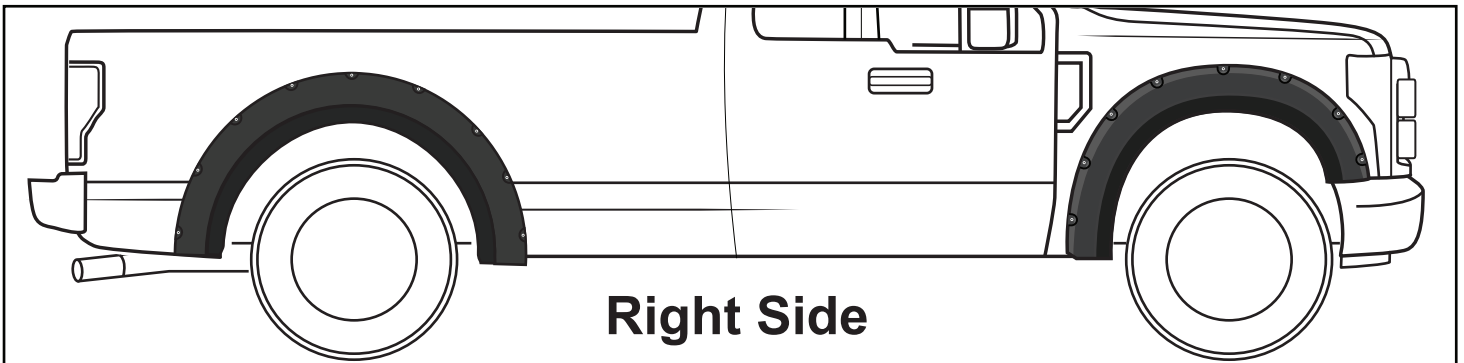

NOTE:

Above images are for reference ONLY, final result may vary.



TYGER[®]

FITMENT OR GAP ISSUE?

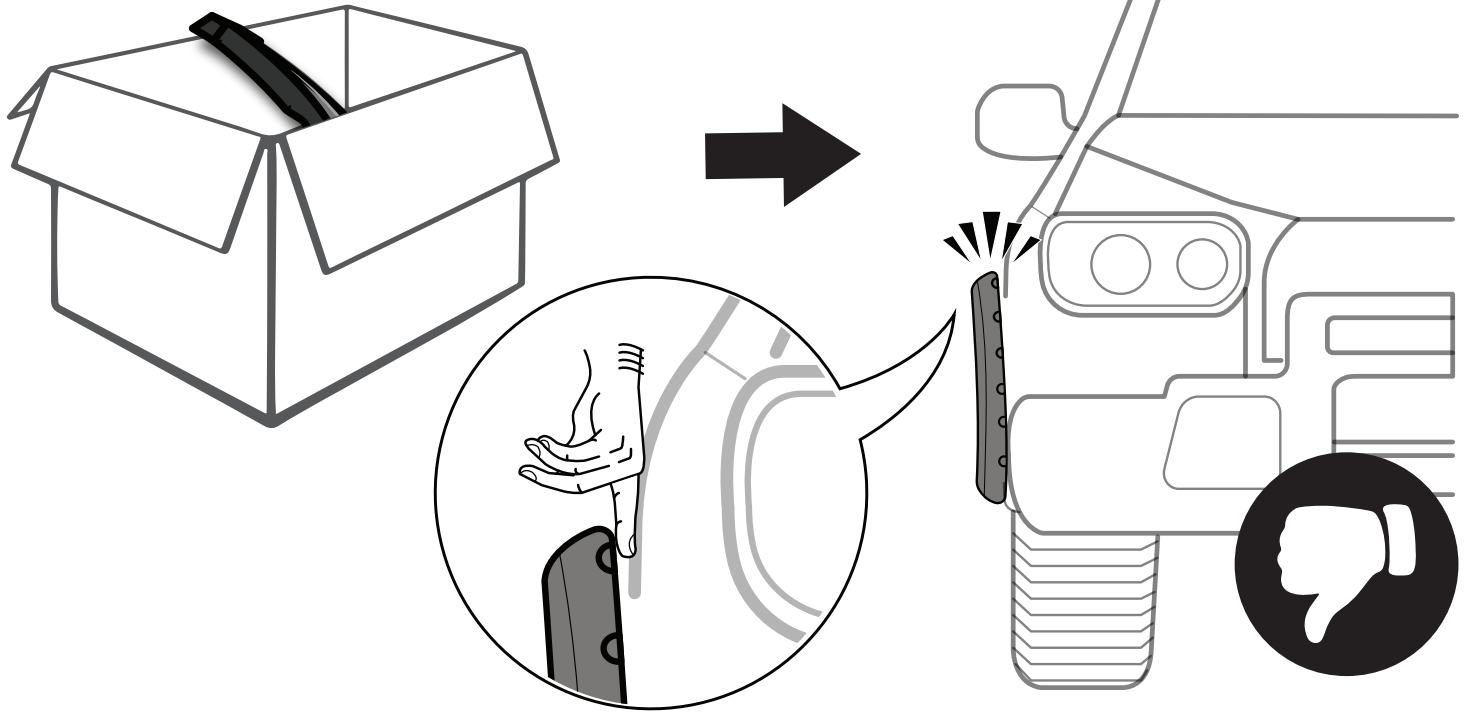

SOLUTION!

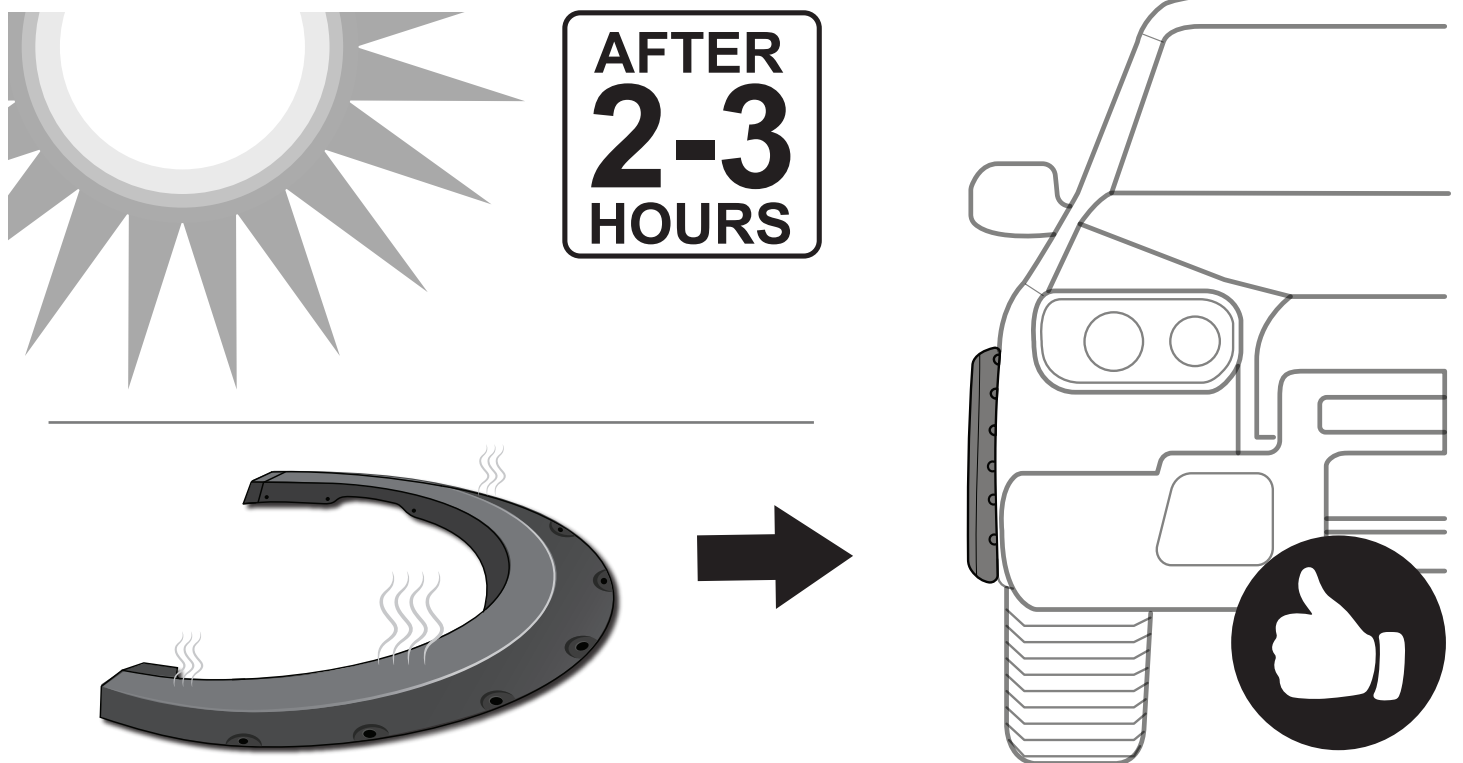

*In winter, heat gun or hair dryer may be used instead.

Discover other fender flares on our website.