



TYGER®

FENDER FLARE

TG-FF8C4128

READ INSTRUCTIONS CAREFULLY BEFORE STARTING INSTALLATION. ONLY FOLLOW THE APPROVED INSTALLATION ACCORDING TO THESE WRITTEN INSTRUCTIONS. FAILURE TO DO SO MAY CAUSE DAMAGE TO YOUR VEHICLE AND INVALIDATE THE WARRANTY.

PRIOR TO INSTALLATION:

- Remove contents from box. Verify all parts are present and free from any defects or damage.
- Make sure installation is done on a non-abrasive surface to avoid scratching the flare surface.
- Verify the fit of each flare to the vehicle body to ensure you have the correct flares for your vehicle.
- Remove existing decals and mud flaps on the vehicle that may interfere with flare installation.
- Do not use any harsh abrasive detergent to clean the flare.

PAINTING

Painted flares cannot be returned. Test fit before painting. We are not responsible for any costs that may incur if flares were painted without test fitting.

- Clean surface to be painted with a good grade degreaser. Do not use lacquer thinner or any solvent based product.
- Wipe flare surface completely dry with a tack rag prior to paint.
- Application of plastic adhesion promoter for PP plastic as per your paint system manufacturer's recommendations is required.
- Use a high quality enamel or polyurethane automotive paint to paint the flares.
- Not recommend to paint the edge trim, but if desired use a flex additive.

WARNING

Dirt or debris may become lodged between flares and vehicle's fenders causing scratching and paint wear from vehicle vibration. TYGER is not responsible for any damage, and installation is done with buyer's understanding that this damage may potentially occur.

SAFETY INFORMATION

- Before driving, ensure that flare is properly secured to vehicle.
- Do not use automatic "brush-style" car wash.
- Periodically check all components for tightness.

Tools Required



Electric Drill



3/32" Drill Bit



T-15 Torx Bit



#2 PH Driver



Socket Wrench



Grease Pencil



Ruler



Pry Tool

Hardware Included



[A]



[B]



[C]



[D]



[E]



[F]



[G]



[H]

EDGE TRIM INSTALLATION

- Peel 2 inches of red backing away from one end of Edge Trim **[A]** .
- Apply Edge Trim over top edge of flare with adhesive side contacting inside edge of flare.
- Press Edge Trim into place and apply thumb pressure to ensure good adhesion, pull away red backing as you work your way around flare edge in one-foot increments. (Fig 1)

NOTE: Do not stretch Edge Trim during application.

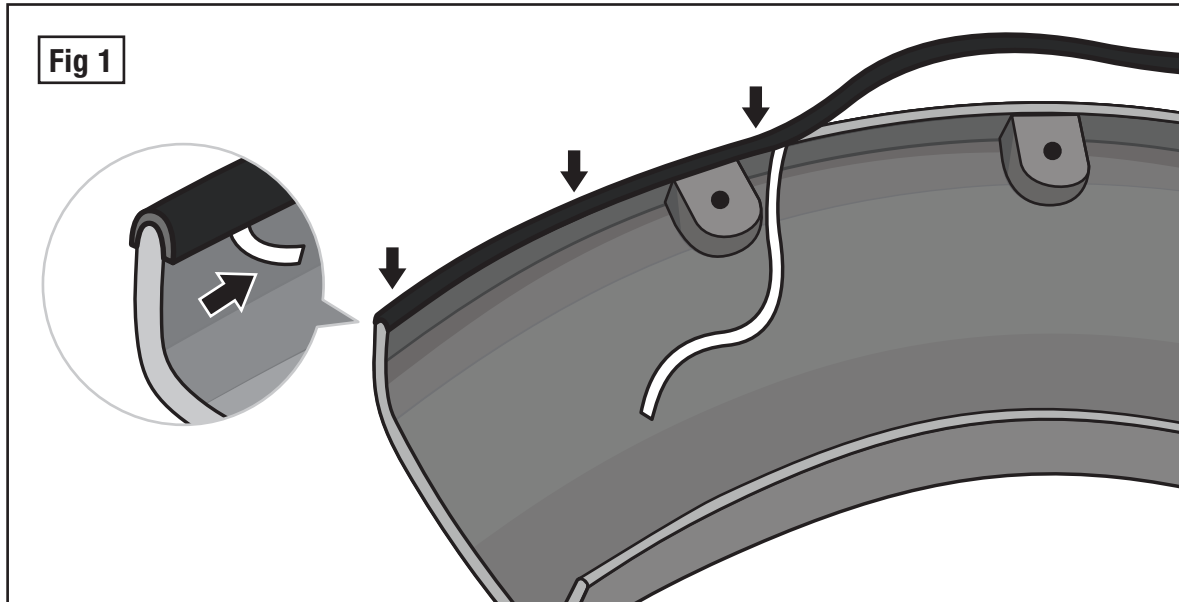

DECORATIVE RIVET INSTALLATION

- Install a Torx Bolt **[B]** with a Washer **[C]** through each of the top holes around the flare and secure using a Nylock Nut **[D]** on the other side. Tighten using a socket wrench and the supplied Torx Bit **[E]**. Do not overtighten as this may damage the flare. (Fig 2)

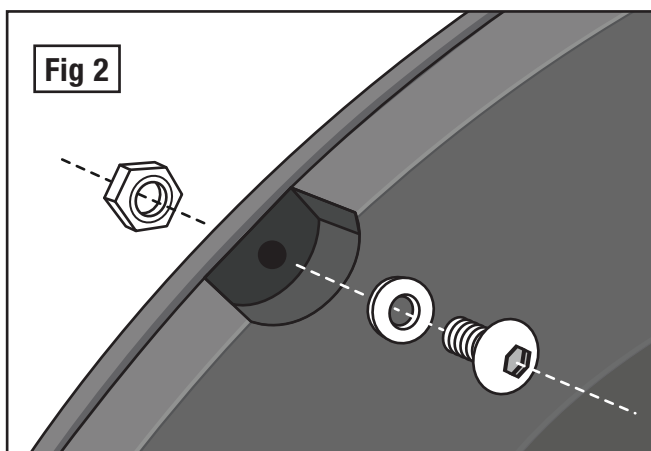

IMPORTANT: Do not drill holes to the vehicle body as rivets are decorative and fasten only to the flare. Do not attempt to use the bolts to fasten flare to vehicle body.

EXTRA NOTES

- All exposed fasteners and bare metal should be treated with rust resistant paint before installing flares. Spray inner fender wells with undercoating after flare installation.
- Modifications may be necessary to maintain a minimum 4" clearance between flares and exhaust pipes. (Exhaust gases should not vent directly onto flares)
- For vehicle with large tires may require lowering bump stops and/or installing steering stops to prevent tire from contacting flare.

Front Driver Side Installation

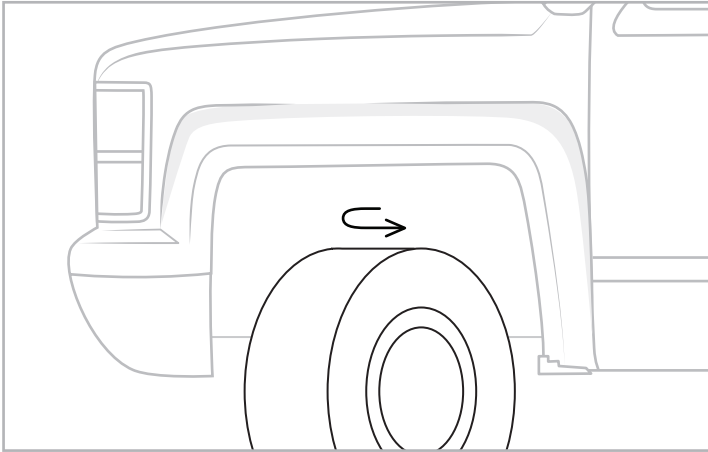

STEP 1: For easier installation, turn wheel outward.

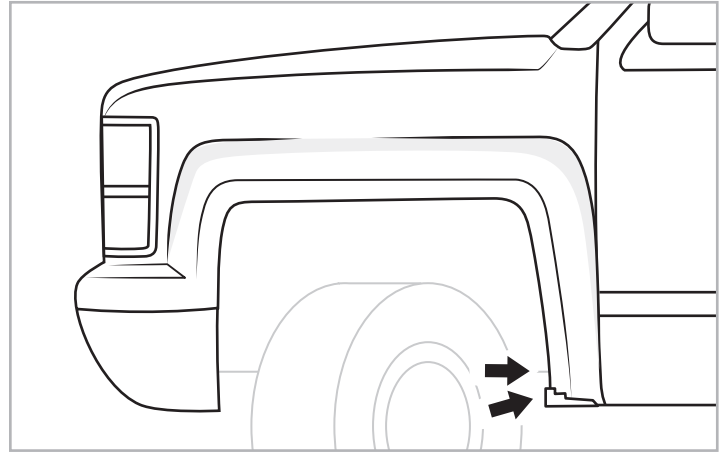

STEP 2: With a T-15 Torx bit, remove 2 factory screws to remove the mudguard.

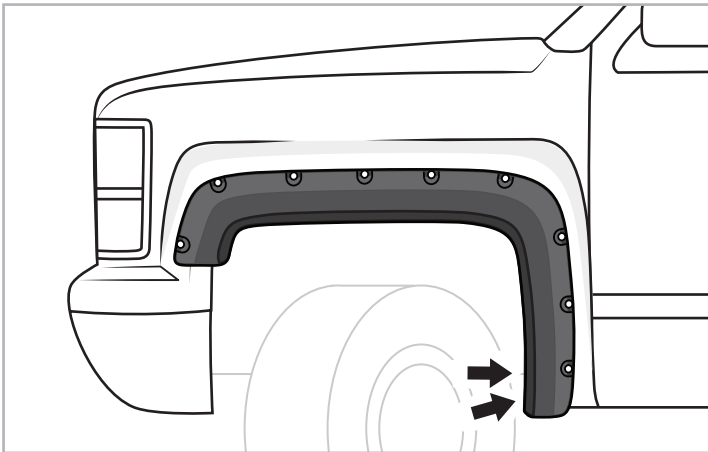

STEP 3: Hold the flare 3 inches below the fender well top lip, push in, and slide up to position it fully against the fender well. Then, install 2 supplied PH Truss Screws [F] through 2 bottom rear holes in flare and into vehicle's factory holes. Do not tighten.

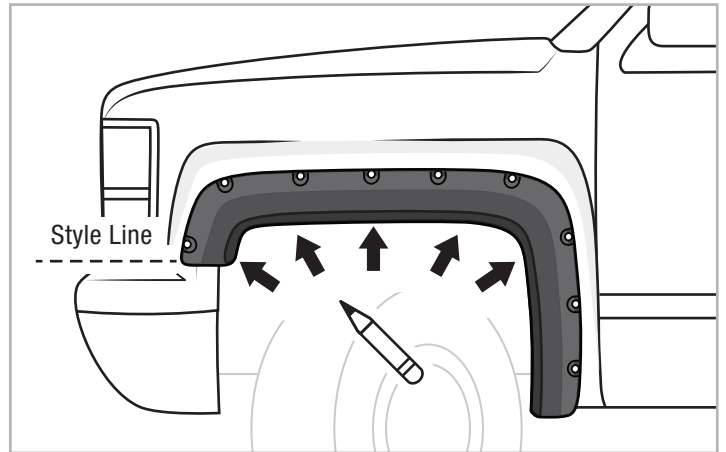

STEP 4: While holding flare in position, with a grease pencil, mark 5 locations using remaining 5 holes in flare as guide. When marking each hole, firmly push flare inward at that position to ensure proper fitment.

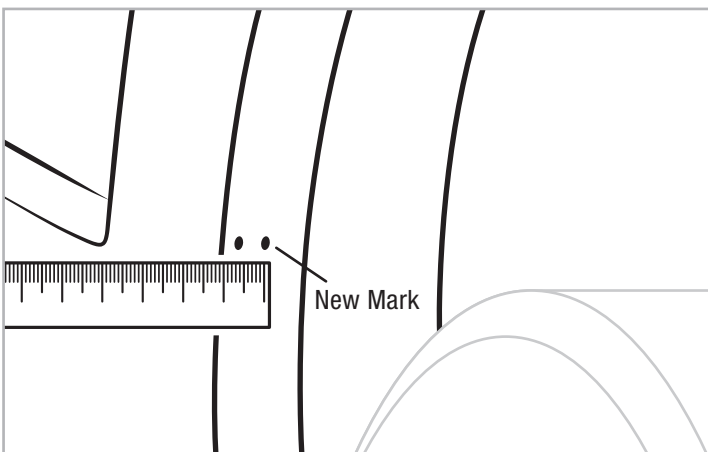

STEP 5: Uninstall 2 screws from Step 3 to remove flare. With a grease pencil, make a new mark that is 10mm inward from the outside edge of the fender and horizontal to the mark made in Step 4.

Note: New mark may be on either side of the first mark.

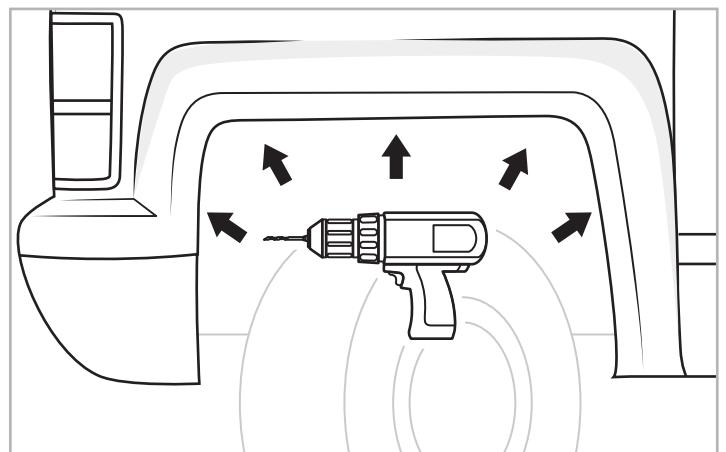

STEP 6: With a 3/32" drill bit, drill holes at new marks made in Step 5.

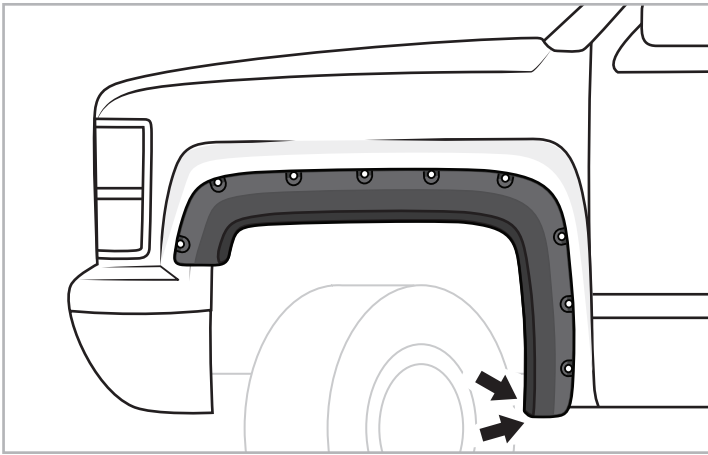

STEP 7: Reposition flare against fender well. Install 2 supplied PH Truss Screws [F] through 2 bottom rare holes in flare and into vehicle's factory holes.

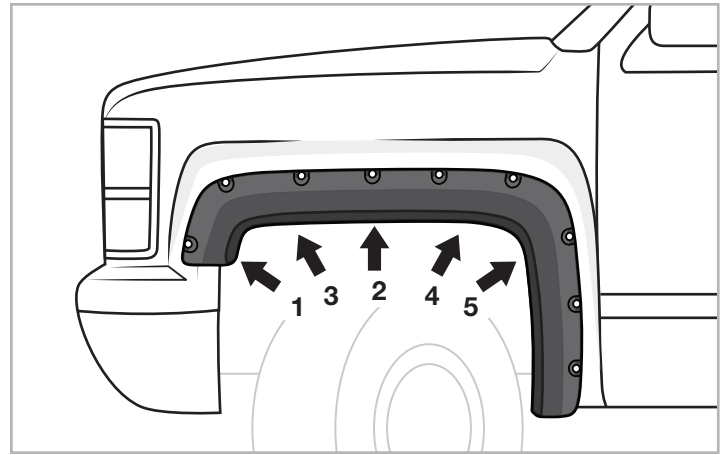

STEP 8: Push flare firmly in place and install 5 supplied PH Drill Screws [G] through holes in flare and into holes drilled in Step 6 in the order indicated above. Then, tighten all screws.

Rear Driver Side Installation

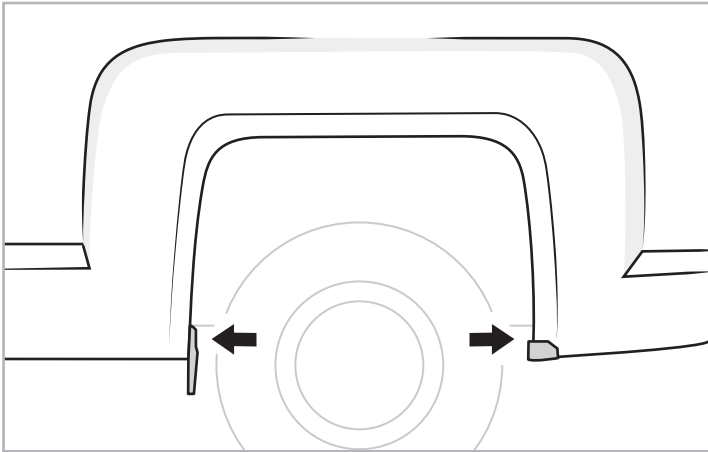

STEP 9: With a T-15 Torx bit socket wrench, remove 2 factory screws.

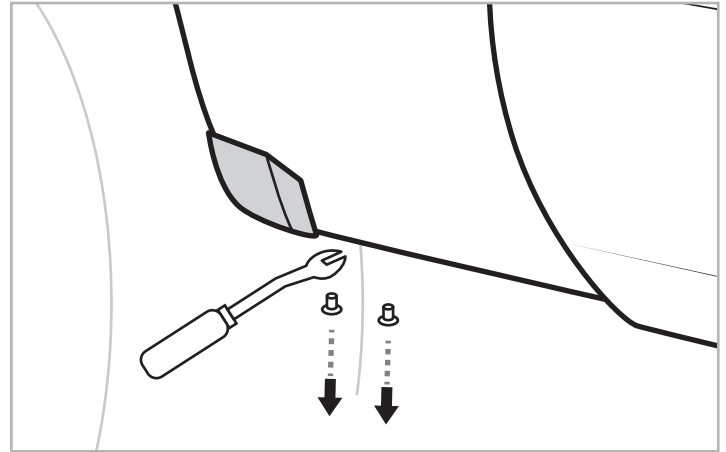

STEP 10: With a pry tool, remove 2 factory retainers from bottom of factory mudguard. Discard mudguard.

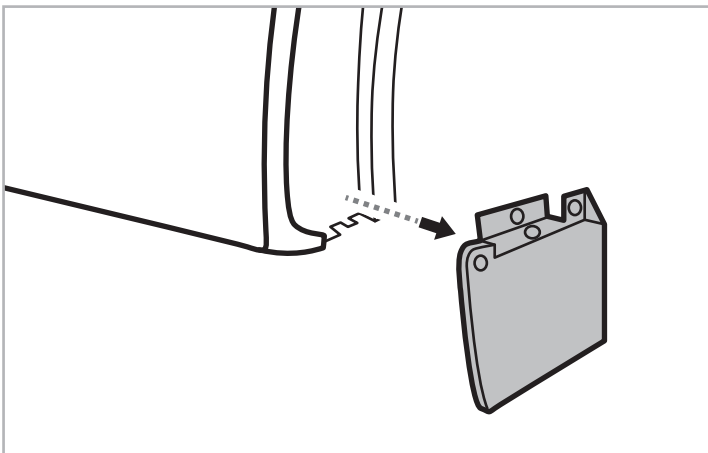

STEP 11: With a T-15 Torx bit socket wrench, remove 4 factory screws to remove the front mudguard.

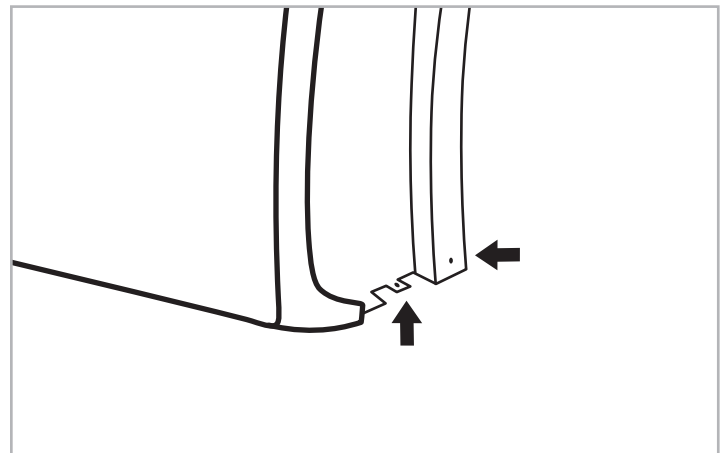

STEP 12: Reinstall 2 factory screws from Step 11 into fender well liner.

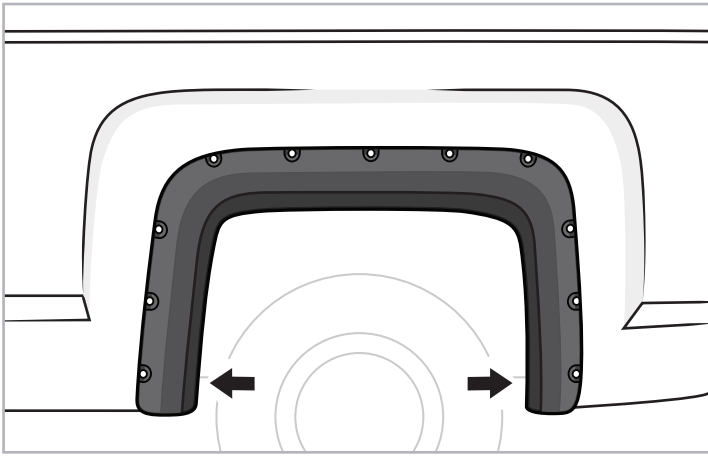

STEP 13: Hold flare in position, then install 2 supplied PH Truss Screws [F]. Do not tighten.

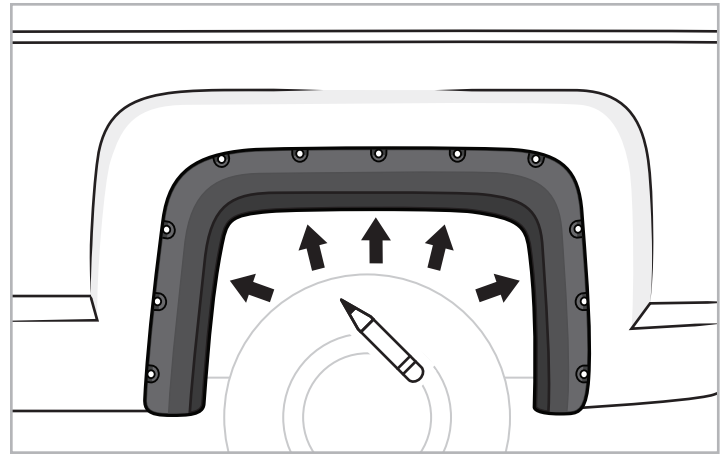

STEP 14: Push firmly on flare; with a grease pencil, mark 5 locations using holes in flare as guide.

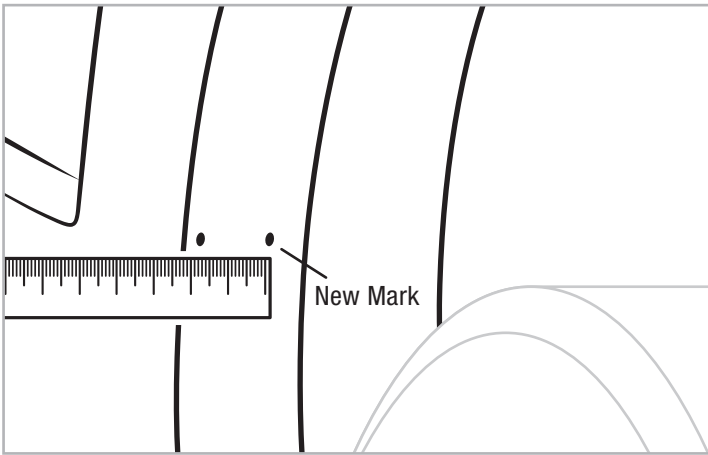

STEP 15: Uninstall 2 screws from Step 13 to remove flare. With a grease pencil, make a new mark that is 22mm inward from the outside edge of the fender and horizontal to the mark made in Step 14.

Note: New mark may be on either side of the first mark.

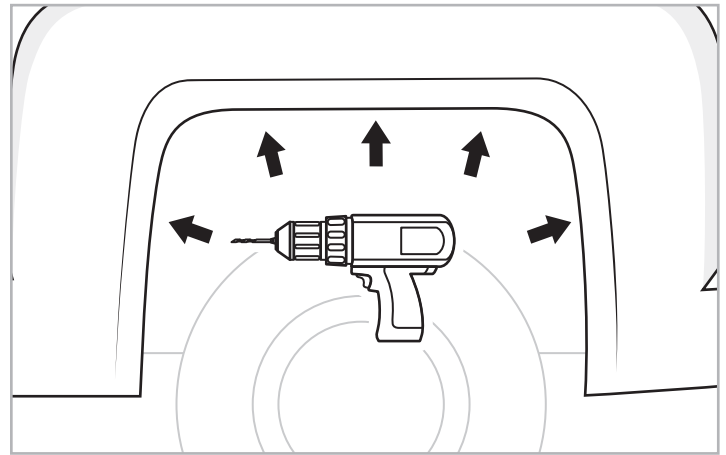

STEP 16: With a 3/32" drill bit, drill holes at new marks made in Step 15.

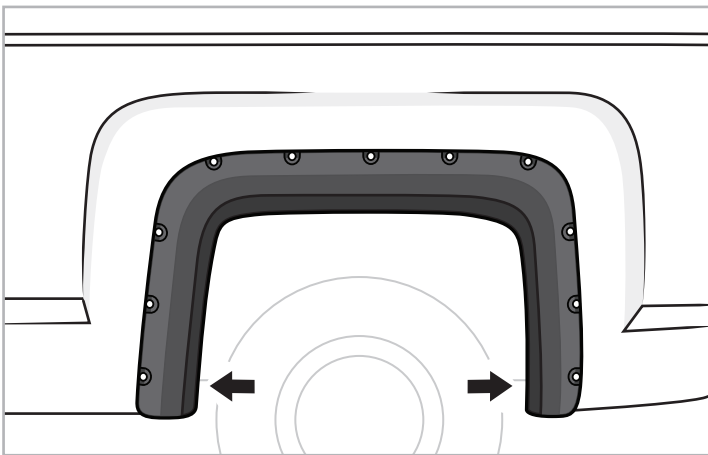

STEP 17: Reinstall 2 supplied PH Truss Screws [F]. Do not tighten.

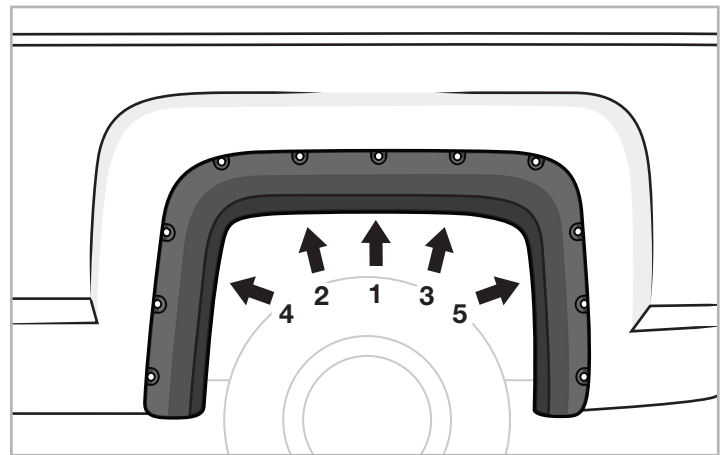

STEP 18: Push flare firmly in place and install 5 supplied PH Drill Screws [G] through holes in flare and into holes drilled in Step 16 in the order indicated above. Then, tighten all screws.

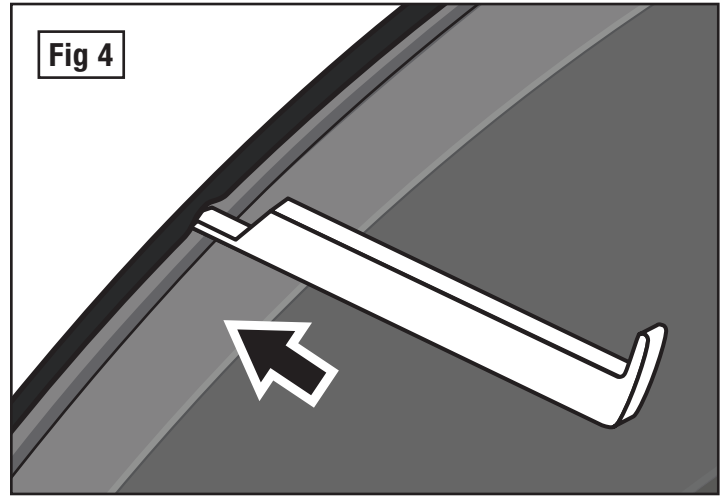
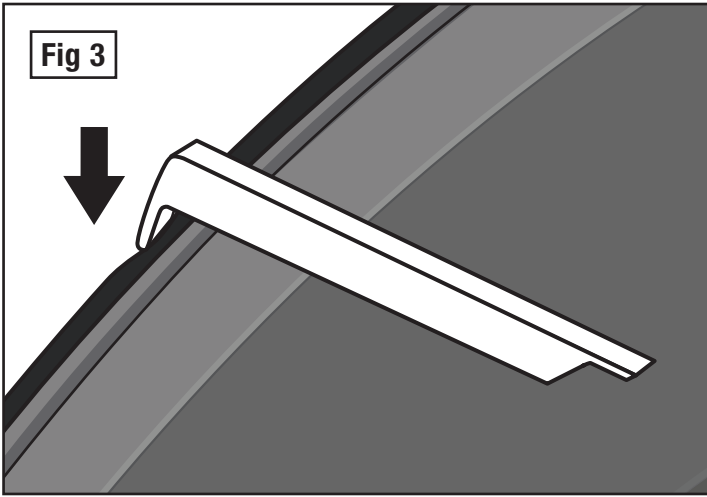

STEP 19: If needed use supplied tool **[H]** to trim outer edge (Fig 3) and inner edge (Fig 4) by inserting tool ends then sliding around the entire edge trims from one end to the other as shown in above pictures.

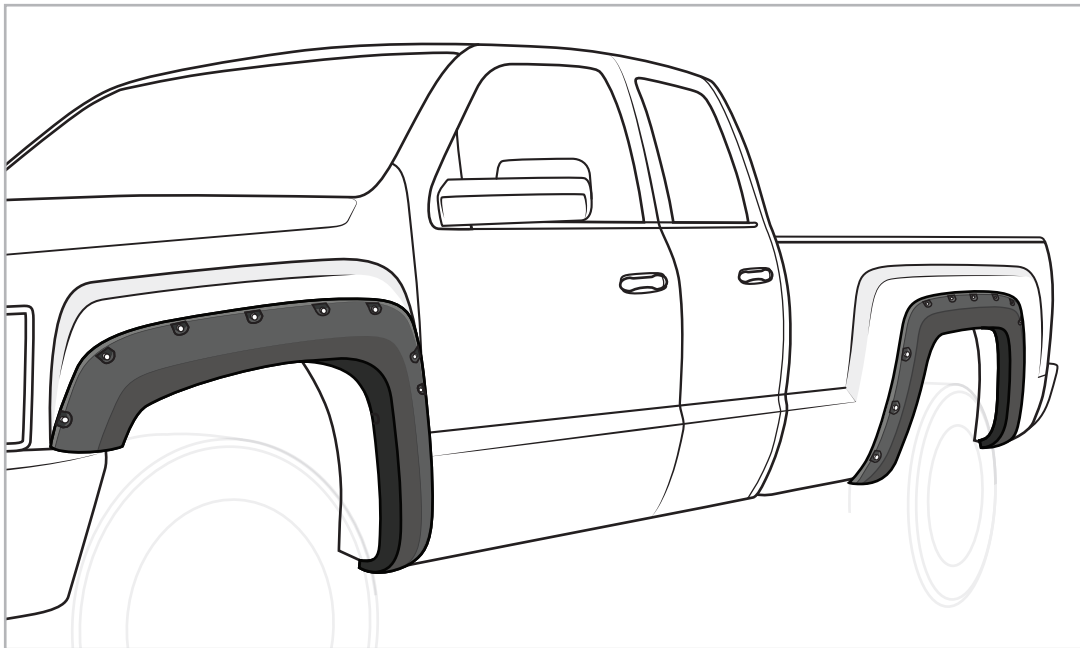

Driver side installation is completed. (Repeat the same steps on passenger side installation.)

FITMENT OR GAP ISSUE?

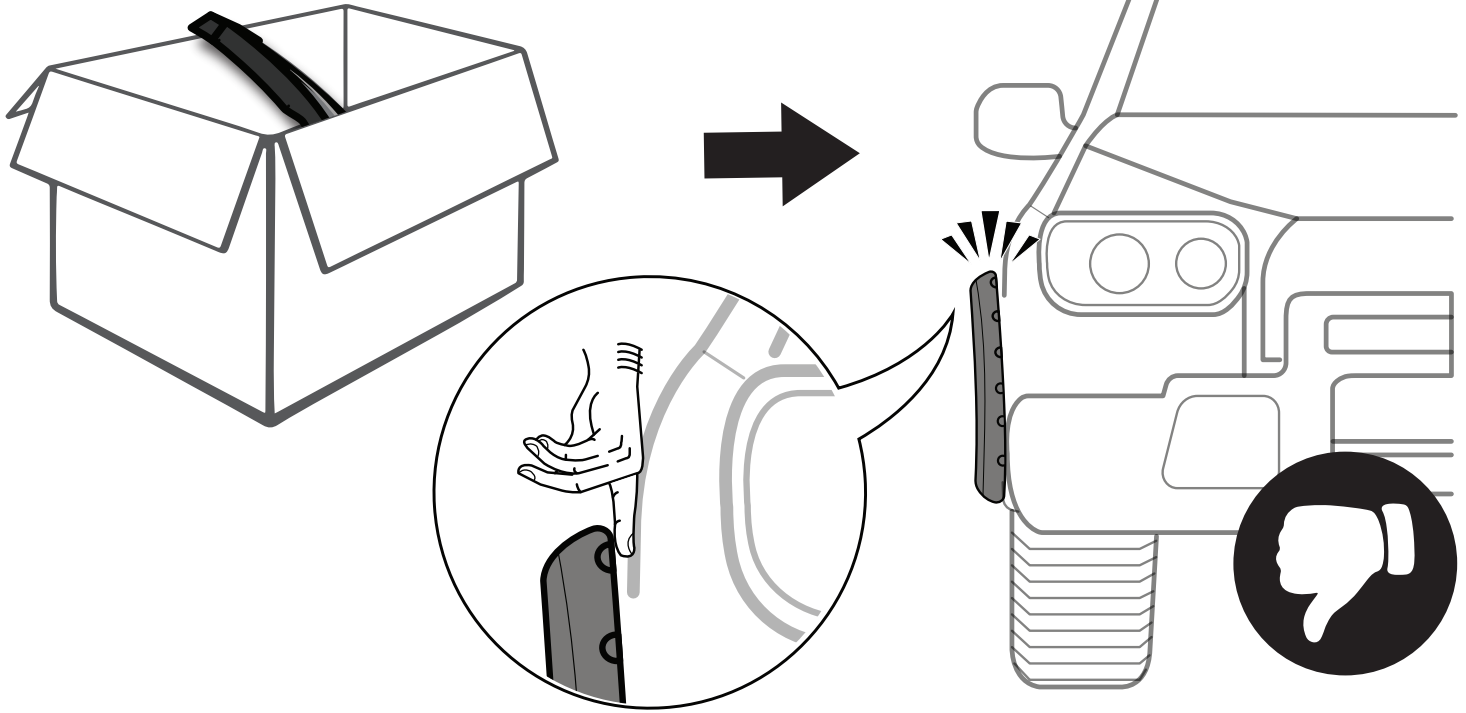

SOLUTION!

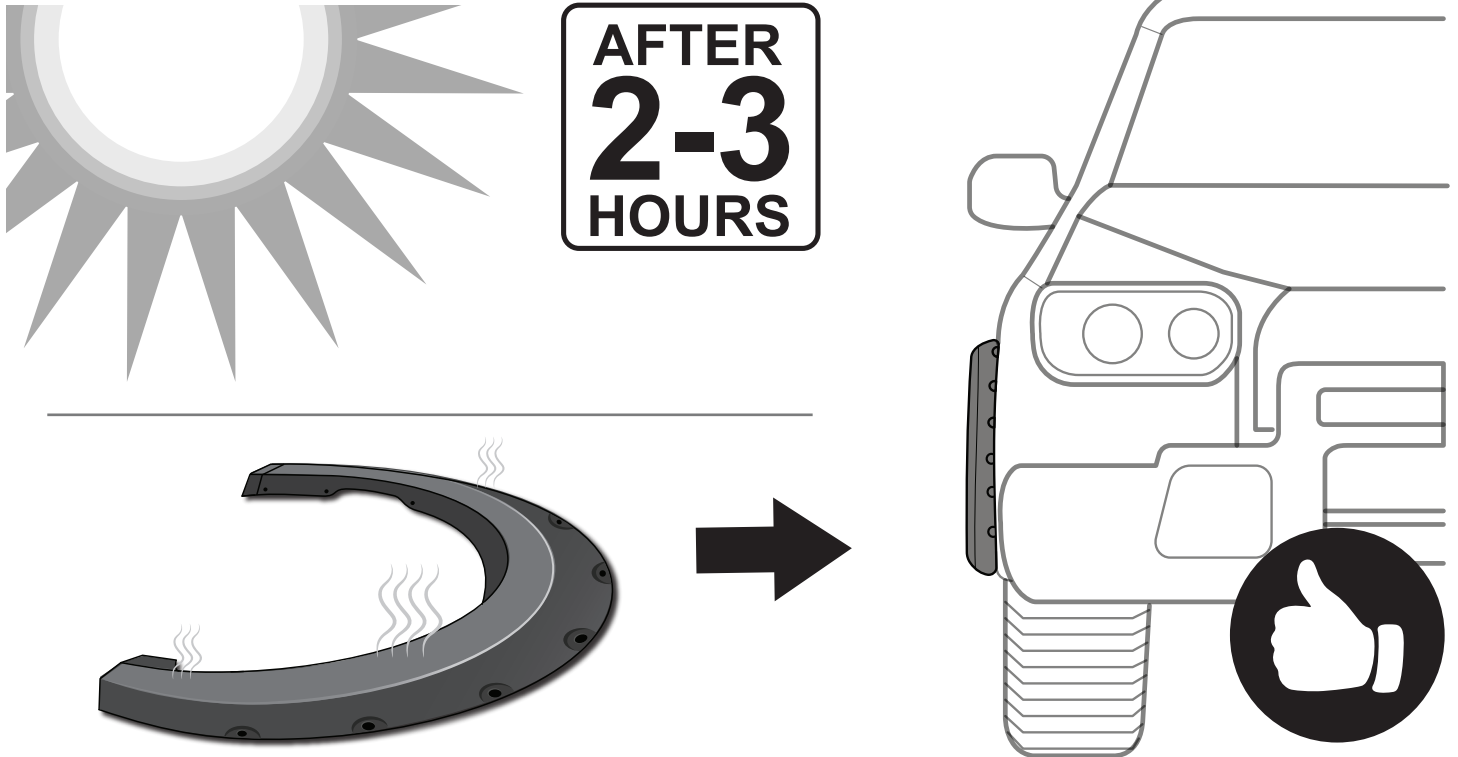

*In winter, heat gun or hair dryer may be used instead.