



FENDER FLARES

TG-FF7J62578

BEFORE INSTALLATION

READ INSTRUCTIONS CAREFULLY BEFORE STARTING INSTALLATION. REMOVE CONTENTS FROM BOX AND VERIFY ALL PARTS ARE PRESENT. FAILURE TO IDENTIFY DAMAGE BEFORE INSTALLATION COULD LEAD TO A REJECTION OF ANY CLAIM.

TORQUE VALUES

Fastener Size	Class 8.8 Torque (ft-lbs)	Class 10.9 Torque (ft-lbs)
6mm	6-7	6-7
8mm	15-16	22-23
10mm	31-32	44-45
12mm	54-55	78-79
14mm	87-88	125-126

Parts List

- x1 Driver/left side Front Fender Flare
- x1 Passenger/right side Front Fender Flare
- x1 Driver/left side Rear Fender Flare
- x1 Passenger/right side Rear Fender Flare
- x2 Cylindrical Sleeves
- x1 Threaded Insert Install Tool
- x2 8-1.25mm x 65mm Button Head Bolts
- x12 8-1.25mm x 25mm Button Head Bolts
- x28 8mm x 16mm x 1.6mm Flat Washers
- x14 8-1.25mm Nylon Lock Nuts
- x14 6mm x 20mm Button Head Combo Bolts
- x14 6mm Threaded Inserts
- x4 1/8" x 1" Self-Tapped Screws
- x1 S=5 Allen Wrench (Use for 8mm Hardware)
- x1 S=4 Allen Wrench (Use for 6mm Hardware)

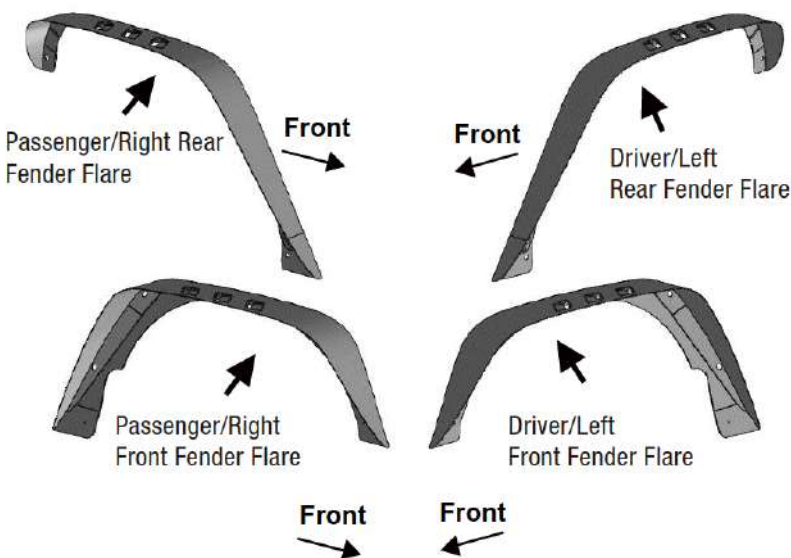



PROCEDURE: REMOVE CONTENTS FROM BOX. VERIFY ALL PARTS ARE PRESENT. READ INSTRUCTIONS CAREFULLY BEFORE STARTING INSTALLATION. SOME DRILLING IS REQUIRED

STEP 1

Start installation on the Passenger/Left side front fender, (Figure 1). Unplug the fender light. Release the clips holding the harness to the fender. Next, locate and remove the factory bolts underneath the fender, (Figures 2 & 3).

STEP 2

The fender flare is held on by multiple clips along the body. Once the factory bolts have been removed, carefully pull the fender up and out from the factory plastic clips. Remove any remaining plastic clips along the fender mounting holes, (Figures 4—6).

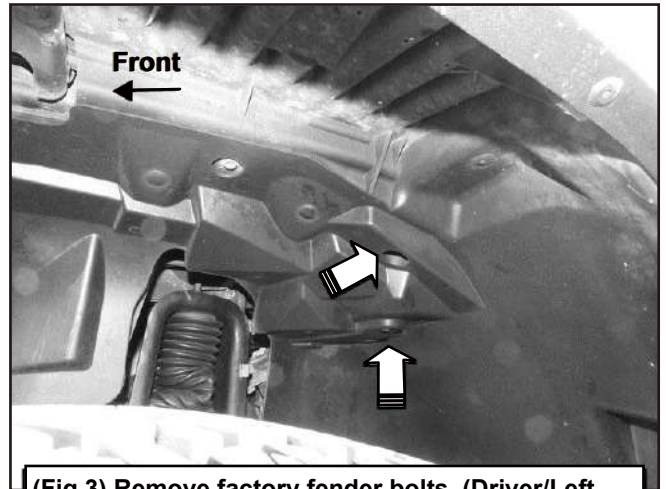

(Fig 3) Remove factory fender bolts, (Driver/Left side shown)

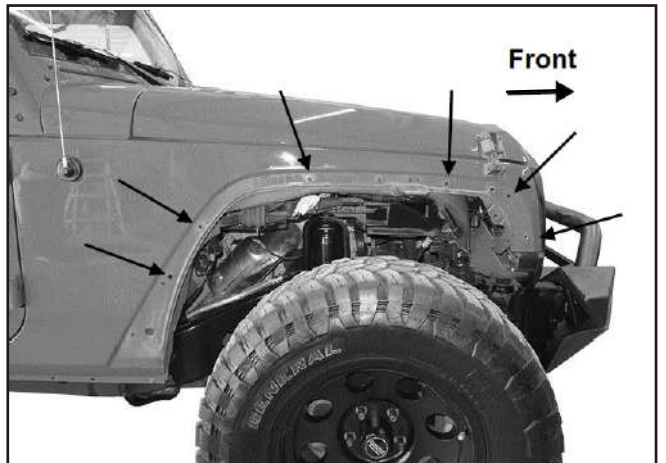

(Fig 4) Front Fender mounting locations

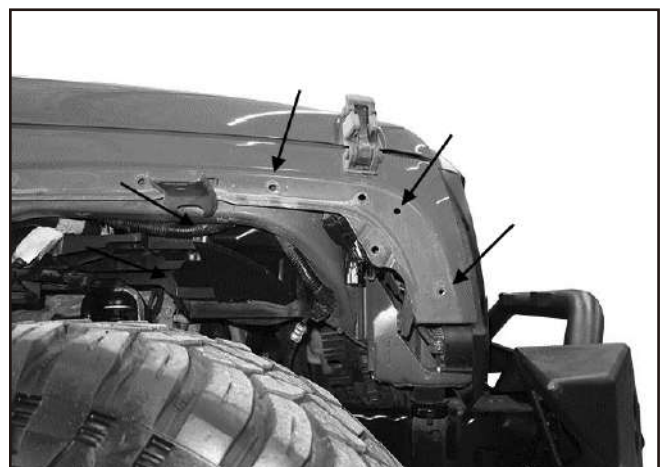

(Fig 5) Forward holes in the front mounting location



(Fig 1) Driver/Left side front fender flare shown

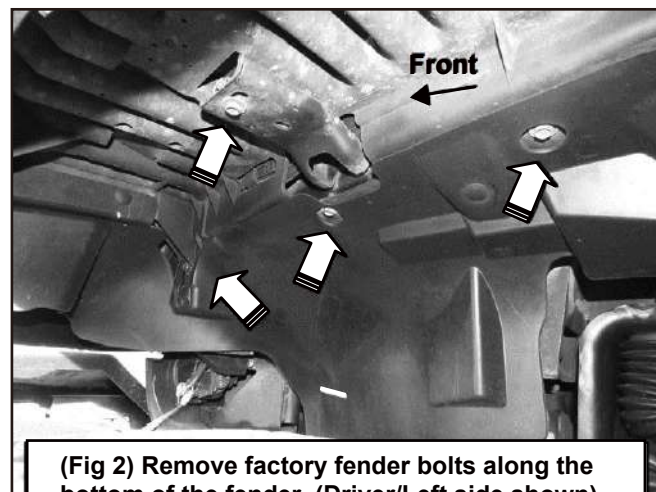

(Fig 2) Remove factory fender bolts along the bottom of the fender, (Driver/Left side shown)

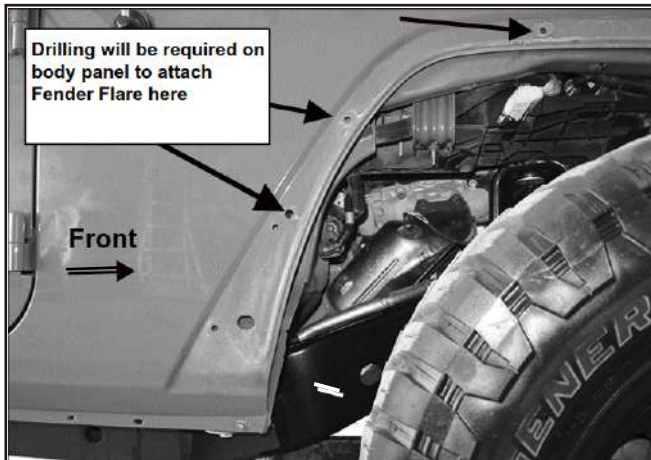

(Fig 6) Use a 7/16" drill bit to drill out the marked holes

STEP 3

Select the Driver/left side Front Fender Flare. Hold and align the Fender Flare up in position to determine the correct mounting holes, (Figures 5 & 6).

STEP 4

Once the holes have been aligned, use (1) 8mm x 25mm Button Head Bolt, (2) 8mm Flat Washers and (1) 8mm Nylon Lock Nut at each fender hole to secure the Fender to the vehicle, (Figures 7 & 8). Repeat this Step for each hole along the Fender Flare. Do not tighten hardware at this time.

NOTE: Drilling will be required on Fender holes that do not line up with a factory fender hole.

(3) 8mm x 25mm Button Head Bolts
(6) 8mm Flat Washers
(3) 8mm Nylon Lock Nuts

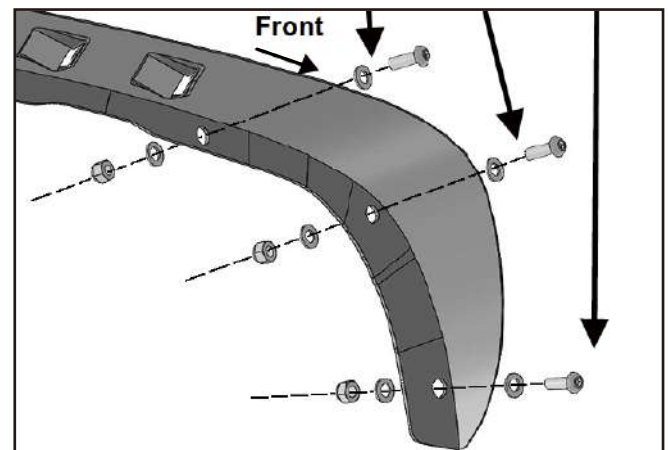

(Fig 7) Attach the Passenger/Right Front Fender to the front location

(3) 8mm x 25mm Button Head Bolts
(6) 8mm Flat Washers
(3) 8mm Nylon Lock Nuts

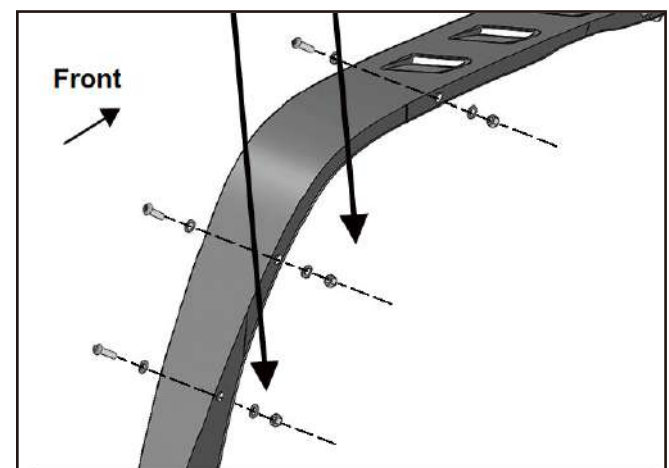

(Fig 8) Attach the Passenger/Right Front Fender to the front location



STEP 5

Some drilling will be required to fully install the Passenger/Right Front Fender Flare. Mark through the remaining holes on the Fender to drill out, (Figure 6). Temporarily remove the Fender Flare. Use a 7/16" drill bit to drill out the marked holes
CAUTION: Do not drill the hole too close to the edges.
IMPORTANT: On the bottom marked hole, there are two layers of sheet metal that must be drilled. Carefully drill through both layers.

STEP 6

Repeat Steps 3 & 4 to attach the Front Fender Flare to the vehicle. On the rear bottom hole, insert (1) sleeve in between the two layers of sheet metal and align sleeve to the drilled holes. Insert (1) 8mm x 65mm Button Head Bolt with (1) 8mm Flat Washer through the Fender, 1st layer of sheet metal, through the sleeve and out the 2nd layer of sheet metal. Use (1) 8mm Flat Washer and (1) 8mm Nylon Lock Nut to secure the bottom of the Fender Flare to the vehicle, (Figure 9). Passenger/Right Front Fender Flare installation is complete, level and adjust Fender Flare as necessary and tighten hardware at this time, (Figure 10).

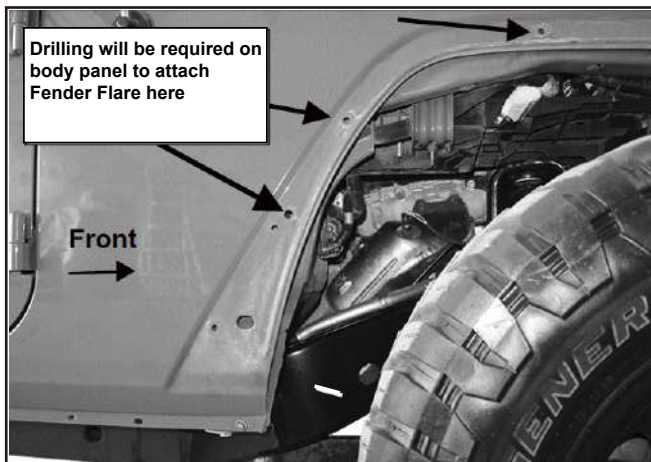

(Fig 6) Use a 7/16" drill bit to drill out the marked holes

8mm x 65mm Button Head Bolt
8mm Flat Washer
Cylindrical Sleeve
8mm Flat Washer
8mm Nylon Lock Nut

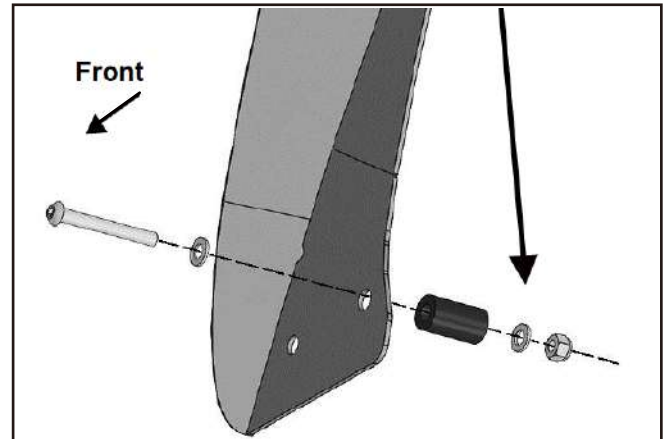

(Fig 9) Insert the cylindrical sleeve in between the 2 layers of sheet metal



(Fig 10) Passenger/Right Front Fender Flare attached to the front location



STEP 7

Move to the rear fender flare, locate and remove the plastic clips attaching the fender to the inner wheel well, (Figures 11 & 12). Next, carefully pull the fender up and out from the factory plastic clips. Remove any remaining plastic clips along the fender mounting holes, (Figure 13).

STEP 8

Temporarily hold the Rear Fender up in position to determine the correct mounting holes. Use an electric drill and 7/16" drill bit, (not included) to drill out the mounting holes in the wheel well, (Figure 13).

VERY IMPORTANT: Only drill through the outer sheet metal to enlarge the holes for a Threaded Insert, do not drill completely through the body.

- a.** Select the Threaded Insert Installation Tool and (1) 6mm Threaded Insert, (Figure 14-A).
- b.** Screw the Insert onto the threaded end of the Insert Tool, (Figure 14-A).
- c.** Firmly hold the Tool and push the Insert into one of the drilled holes, (Figure 14-B).
- d.** Insert should fit snug into the drilled hole. Lightly tap the Tool and Insert into the hole with a small hammer if necessary.
- e.** Firmly hold the Insert Tool in place and turn the hex bolt clockwise to tighten the bolt and expand the Insert in the hole (Figure 14-C).
- f.** Once Insert is fully compressed and expanded, remove the Tool from the Insert. **WARNING:** Do not overtighten Insert or damage to the Insert may result.
- g.** Repeat Steps 8a—8f to insert (6) Threaded Inserts into the remaining (6) drilled holes



(Fig 11) Passenger/Right Front Fender Flare attached to the front location

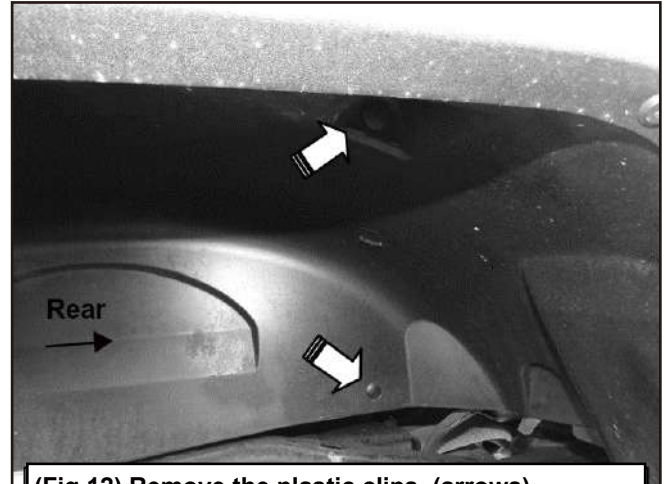

(Fig 12) Remove the plastic clips, (arrows). (Driver/Left side shown)



(Fig 13) Rear Fender mounting locations

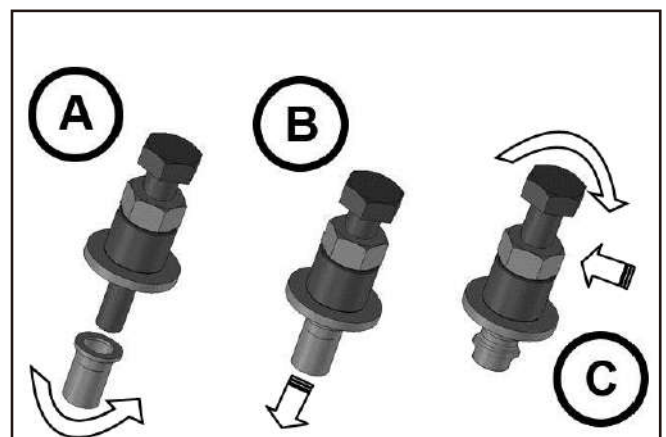

(Fig 10) Passenger/Right Front Fender Flare attached to the front location



STEP 9

Next, select the Passenger/Right Rear Fender Flare. Use (7) 6mm Button Head Combo Bolts to attach the Rear Fender to the threaded inserts on the body panel, (Figures 15, 16 & 18).

STEP 10

Use the provided (2) 1/8" x 1" Self-Tapped Screws to attach the ends of the Rear Fender to the body panel, (Figure 17). Level and adjust Fender Flare as necessary and tighten all hardware at this time.

(3) 6mm Button Head Combo Bolts

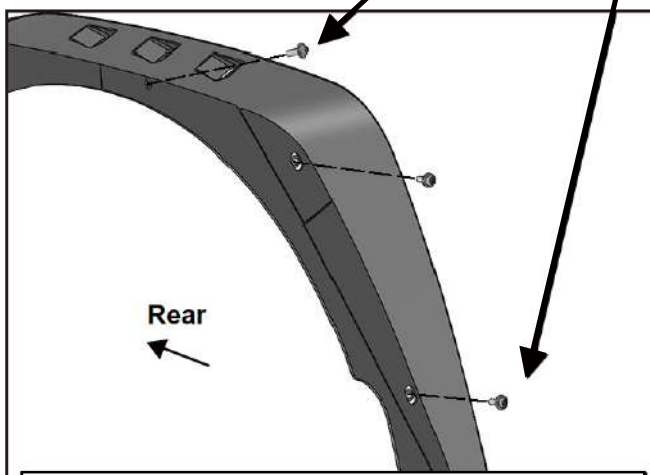

(Fig 15) Attach the Passenger/Right Front Fender to the rear location

(3) 6mm Button Head Combo Bolts

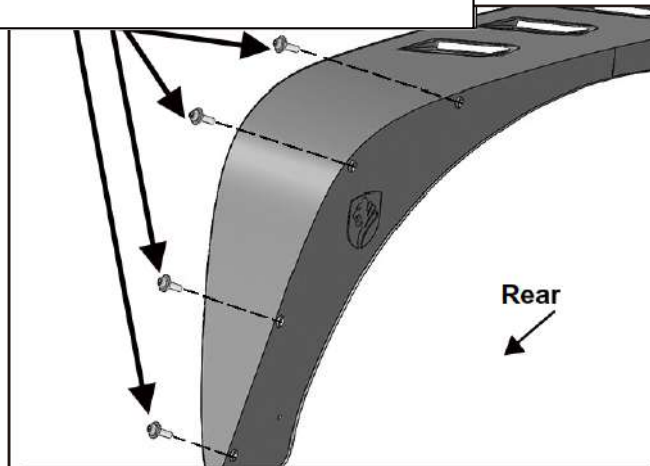

(Fig 16) Attach the Passenger/Right Front Fender to the rear location

1/8in x 1in Self-tapping Screw

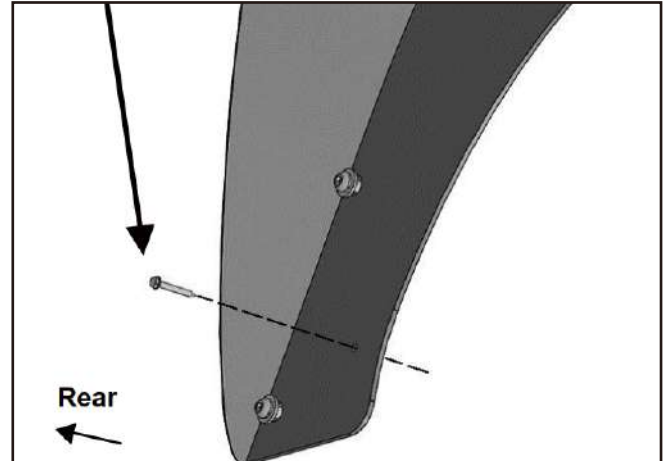

(Fig 17) Use the self-tapped screws to attach the ends of the Rear Fender to the body panel



(Fig 18) Passenger/Right Rear Fender Flare attached to the rear location



TYGER[®]

STEP 11

Repeat Steps 1—10 to attach the Driver/Left Front & Rear Fender Flares.

STEP 12

Reuse the factory fender bolts to reinstall the fender liner, (trim fender liner for better look), optional.

STEP 13

Do periodic inspections to the installation to make sure that all hardware is secure and tight.

To protect your investment,

Do not use any type of polish or wax that may contain abrasives that could damage the finish. Mild soap may be used to clean the Fenders