



# TYGER®

## FENDER FLARE

TG-FF6C4298

READ INSTRUCTIONS CAREFULLY BEFORE STARTING INSTALLATION. ONLY FOLLOW THE APPROVED INSTALLATION ACCORDING TO THESE WRITTEN INSTRUCTIONS. FAILURE TO DO SO MAY CAUSE DAMAGE TO YOUR VEHICLE AND INVALIDATE THE WARRANTY.

### PRIOR TO INSTALLATION:

- Remove contents from box. Verify all parts are present and free from any defects or damage.
- Make sure installation is done on a non-abrasive surface to avoid scratching the flare surface.
- Verify the fit of each flare to the vehicle body to ensure you have the correct flares for your vehicle.
- Remove existing decals and mud flaps on the vehicle that may interfere with flare installation.
- Do not use any harsh abrasive detergent to clean the flare.

### PAINTING

Painted flares cannot be returned. Test fit before painting. We are not responsible for any costs that may incur if flares were painted without test fitting.

- Clean surface to be painted with a good grade degreaser. Do not use lacquer thinner or any solvent based product.
- Wipe flare surface completely dry with a tack rag prior to paint.
- Application of plastic adhesion promoter for PP plastic as per your paint system manufacturer's recommendations is required.
- Use a high quality enamel or polyurethane automotive paint to paint the flares.
- Not recommend to paint the edge trim, but if desired use a flex additive.

### WARNING

Dirt or debris may become lodged between flares and vehicle's fenders causing scratching and paint wear from vehicle vibration. TYGER is not responsible for any damage, and installation is done with buyer's understanding that this damage may potentially occur.

### SAFETY INFORMATION

- Before driving, ensure that flare is properly secured to vehicle.
- Do not use automatic "brush-style" car wash.
- Periodically check all components for tightness.

### Tools Required



Socket Wrench



3/8" Wrench



7mm Socket



#2 PH driver



Grease Pencil

### Hardware Included



[A]

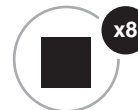

[B]



[C]



[D]



[E]

V200720

## Front Driver Side Flare Installation

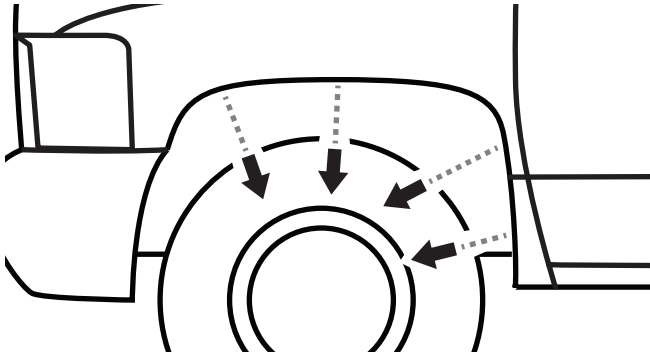

(1) Using a 7 mm socket wrench, remove 4 factory screws.

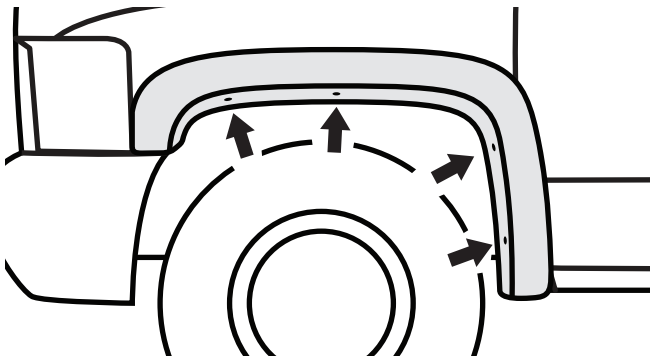

(2) Hold flare in position, reinstall 4 factory screws. Ensure proper flare fitment, then tighten all screws.

Repeat Step 1 - 2 for front passenger side flare installation.

## Rear Driver Side Flare Installation

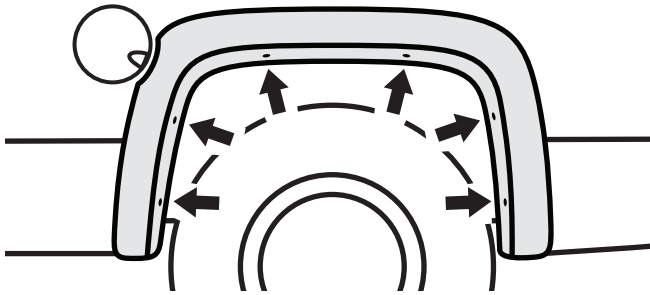

(3) Hold flare in position, with a grease pencil, mark 6 locations using holes in flare as guide. Then, remove flare.

NOTE: If fender liner is installed, remove factory Tufloks first.

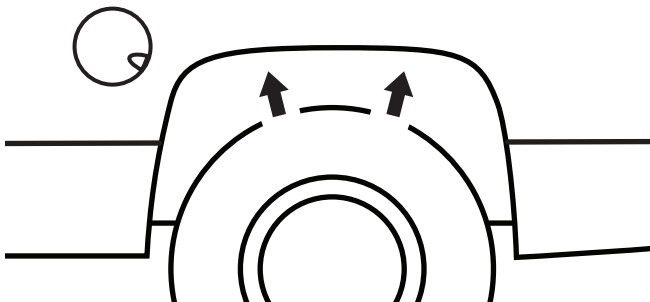

(4) Slide the supplied U-clips **[A]** over top 2 factory holes. Refer to Fig 1 on the last page.

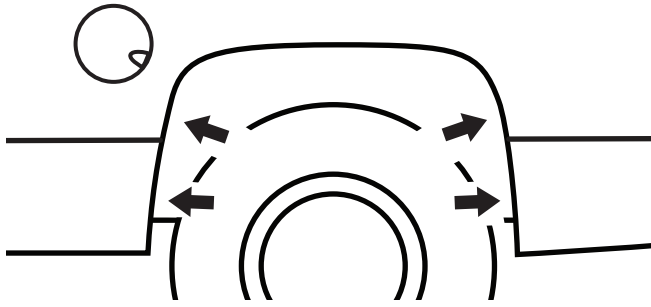

(5) Stick the supplied Tabs **[B]** over the other 4 marks made in Step 3, align one side of the Tab with the inside edge of the fender lip.

(6) Slide the supplied S-Clip **[C]** over each Tab installed in Step 5. Refer to Fig 2 on the last page.

**NOTE:** S-clips on the bottom may need to be pinched in order to stay in position on the fender.

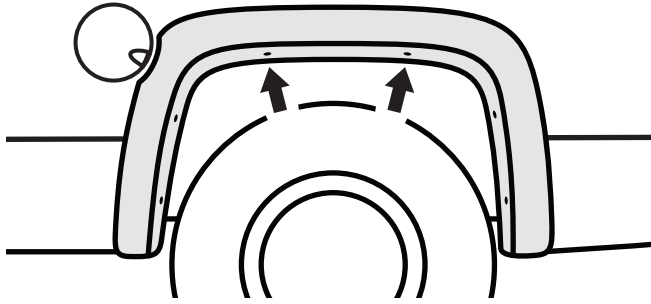

(7) Reposition flare. Install 2 supplied PH Truss Tap Screws **[D]** through top 2 holes in flare, into U-clips installed in Step 4, and into vehicle's factory holes. Do not tighten.

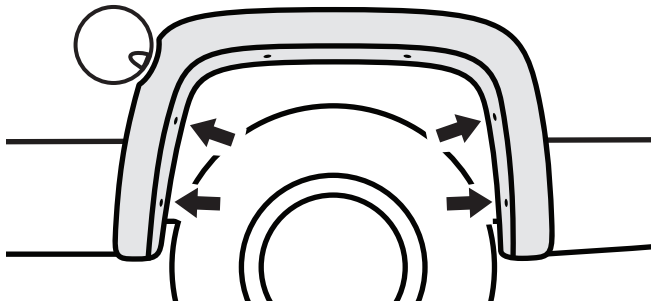

(8) Install 4 supplied PH Metal Screws **[E]** through remaining holes in flare and into S-clips installed in Step 6. Ensure proper flare fitment, then tighten all screws.

Repeat Step 3 - 8 for rear passenger side flare installation.

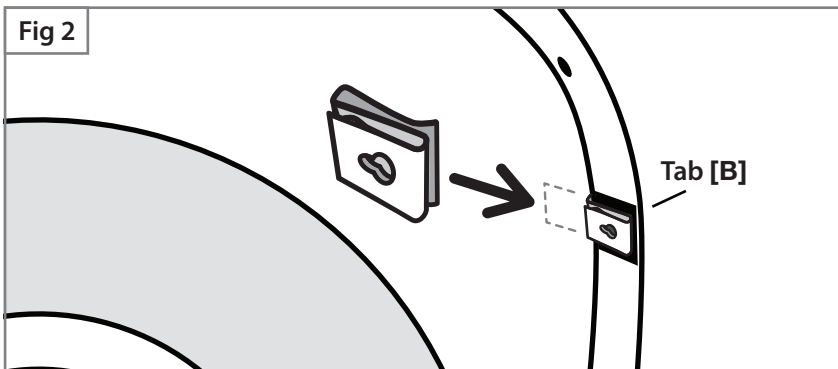
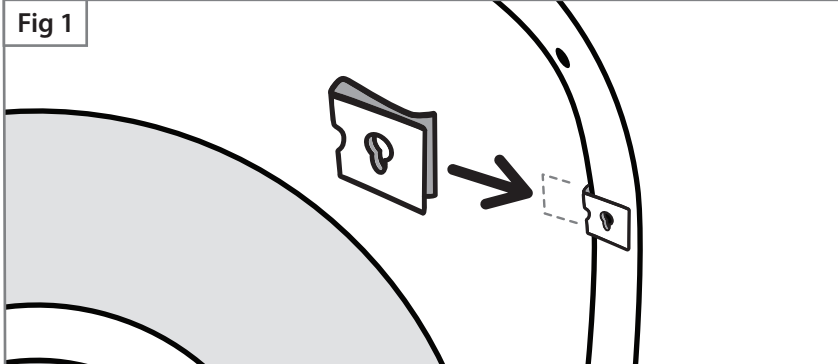

## EXTRA NOTES

- All exposed fasteners and bare metal should be treated with rust resistant paint before installing flares. Spray inner fender wells with undercoating after flare installation.

- Modifications may be necessary to maintain a minimum 4" clearance between flares and exhaust pipes. (Exhaust gases should not vent directly onto flares)

- For vehicle with large tires may require lowering bump stops and/or installing steering stops to prevent tire from contacting flare.

# FITMENT OR GAP ISSUE?

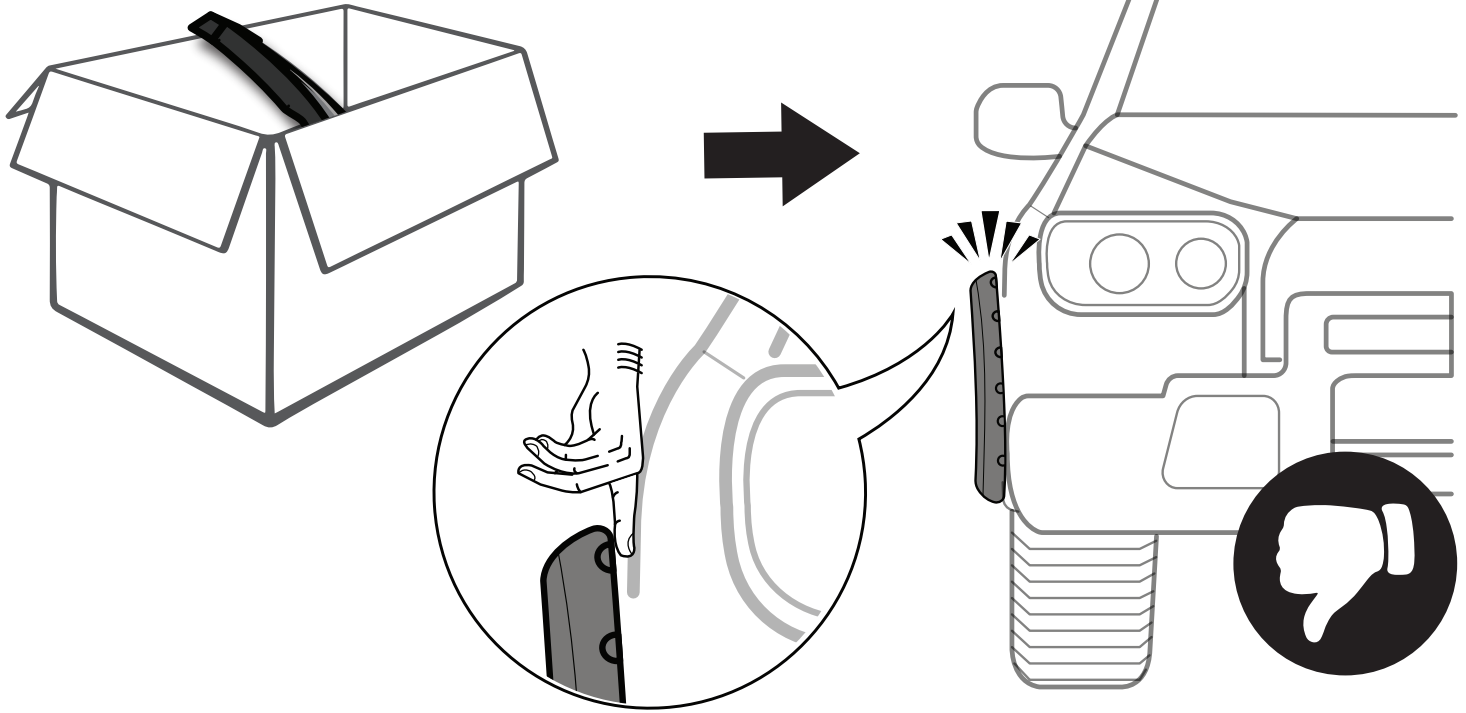

# SOLUTION!

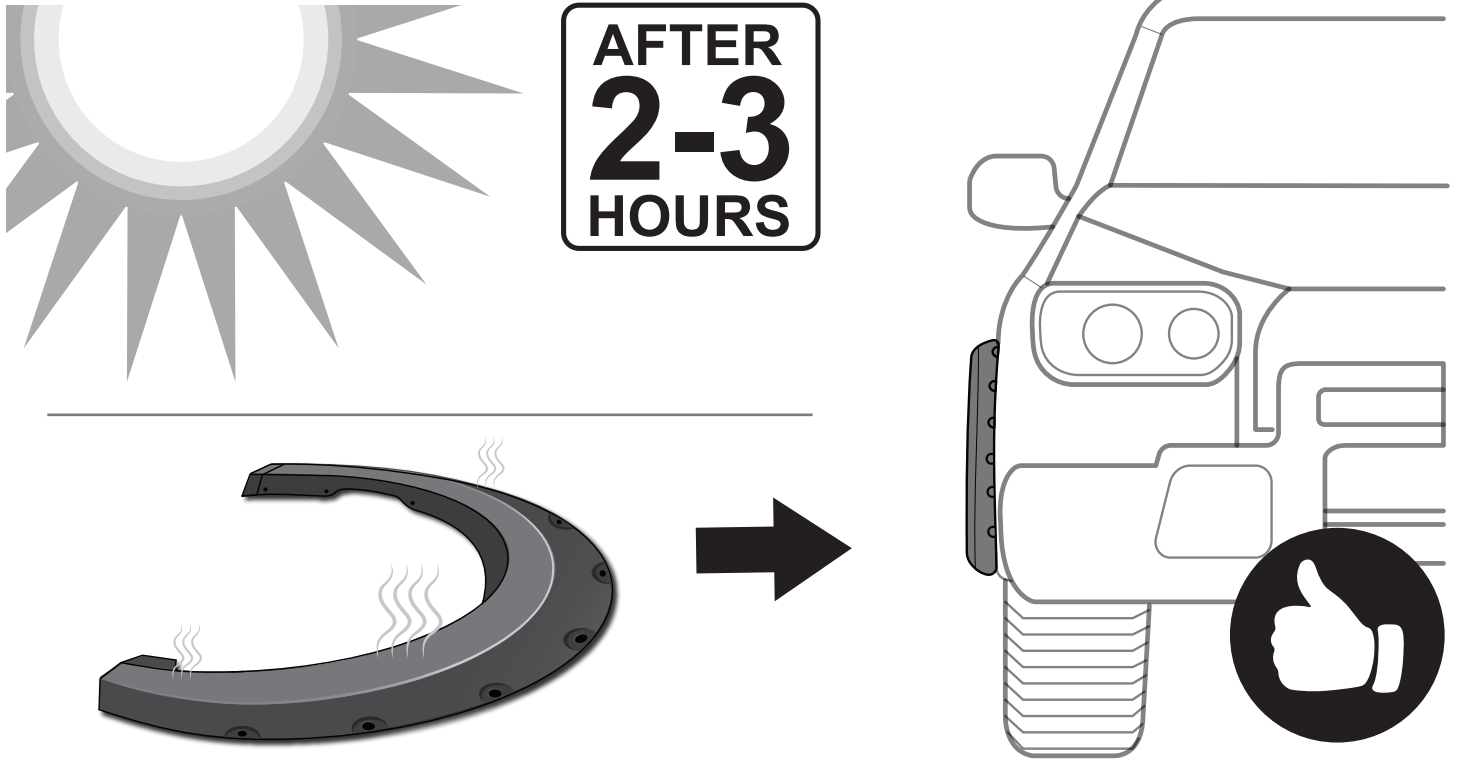

\*In winter, heat gun or hair dryer may be used instead.