



## REAR BUMPER

TG-BP9J85398

### BEFORE INSTALLATION

READ INSTRUCTIONS CAREFULLY BEFORE STARTING INSTALLATION. REMOVE CONTENTS FROM BOX AND VERIFY ALL PARTS ARE PRESENT. FAILURE TO IDENTIFY DAMAGE BEFORE INSTALLATION COULD LEAD TO A REJECTION OF ANY CLAIM. IF MISSING PARTS OR ANY DAMAGE FOUND, PLEASE TAKE A PICTURE FOR THE CLAIM PURPOSE.

### TORQUE VALUES

Fastener Size	Class 8.8 Torque (ft-lbs)	Class 10.9 Torque (ft-lbs)
6mm	6-7	6-7
8mm	15-16	22-23
10mm	31-32	44-45
12mm	54-55	78-79
14mm	87-88	125-126

### Parts List

- x1 TYGER rear Bumper
- x2 12-1.75mm x 40mm Hex Bolts
- x2 12mm x 24mm x 2.5mm Flat Washers
- x2 12mm Lock Washers
- x2 10mm Double Bolt Plates
- x4 10mm x 20mm x 2mm Flat Washers
- x4 10mm Nylon Lock nuts
- x1 S=4mm Wrench

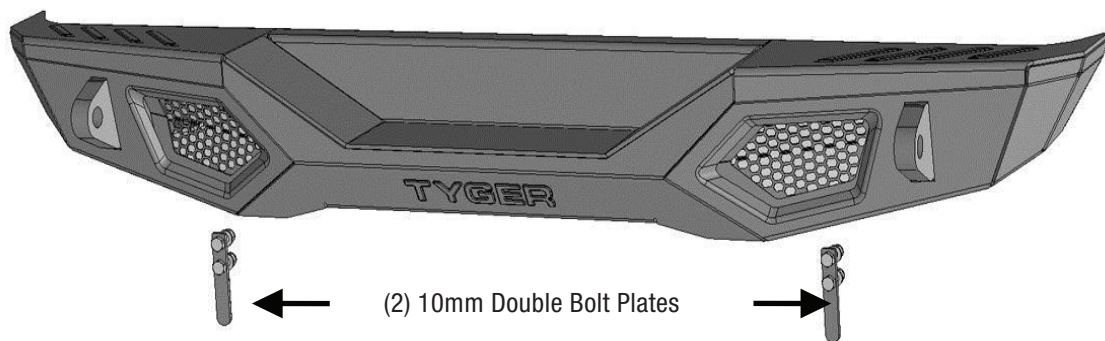



PROCEDURE: REMOVE CONTENTS FROM BOX. VERIFY ALL PARTS ARE PRESENT. READ INSTRUCTIONS CAREFULLY BEFORE STARTING INSTALLATION. ASSISTANCE IS RECOMMENDED.

## STEP 1

Start installation under the driver/left side of the rear bumper. Remove the plastic bumper end cap if equipped, (Figure 1).

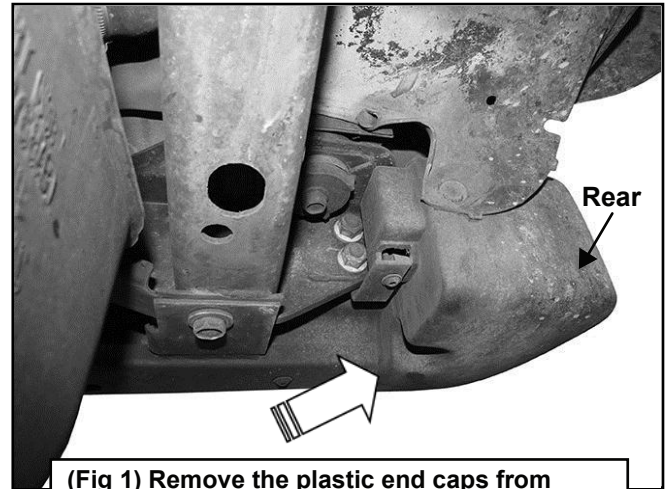

(Fig 1) Remove the plastic end caps from the bumper

## STEP 2

Next, remove the hex nuts and bolt attaching the bumper to the end and bottom of the frame, (Figure 2).

**IMPORTANT:** Factory bolts may be very tight or rusted in place. Use of penetrating lubricant is highly recommended before attempting to remove hardware.

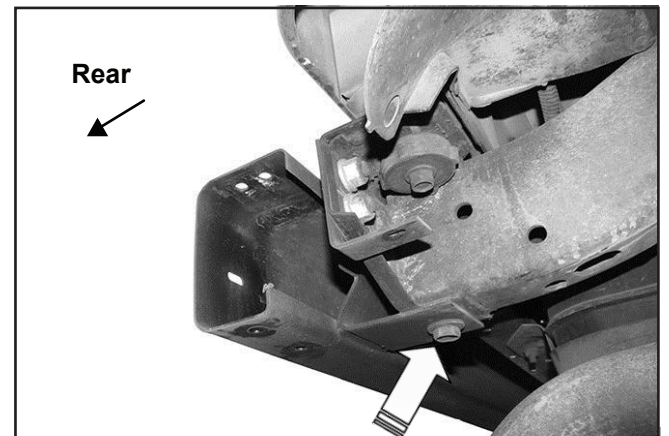

(Fig 2) Remove bumper bolt from the bottom of the frame (arrow). Remove hex nuts attaching bumper to frame (passenger/right side pictured)

## STEP 3

Repeats Steps 1 & 2 to remove the passenger/right bumper end cap.

## STEP 4

With assistance, remove the bumper from the end of the frame, (Figure 3).



(Fig 3) Bumper assembly removed



# TYGER®

## STEP 5

**LED light installation at ends of bumper, (LED lights not included) .**

- Remove the screen from the back of the driver/left opening, (Figure 4).
- Attach light to mounting tab at top of opening. Check for clearance around light.
- Repeat the above Steps for passenger/right side light installation.
- Follow light manufacturer's instructions to install, adjust and properly wire the light to the vehicle electrical system.

## STEP 6

With assistance, carefully place the Bumper over the end of the frame.

## STEP 7

Select (1) 10mm Double Bolt Plate. Insert the Bolt Plate up and into the mounting plate on the back of the driver/left side of the Bumper, (Figure 5). Insert the Bolt Plate through the (2) holes in the mounting tab and through the bumper mounting plate on the back of the frame. Attach the Bolt Plate in the Bumper to the frame with the included (2) 10mm Flat Washers and (2) 10mm Nylon Lock Nuts, (Figure 5). Next, attach the mounting tab on the bottom of the Bumper to the bottom of the frame with the factory hardware or on metric threaded frames, use the included (1) 12mm x 40mm Hex bolt, (1) 12mm Lock Washer and (1) 12mm Flat Washer, (Figures 5 & 6). Do not tighten hardware at this time. Repeat this Step to attach the passenger/right side of the Bumper to the end of the frame.

## STEP 8

Stand back from the vehicle and check to see that the Bumper is centered and level on the vehicle and adjust as required. Once properly aligned, fully tighten all hardware.

## STEP 9

Do periodic inspections of the installation to make sure that all hardware is secure and tight.

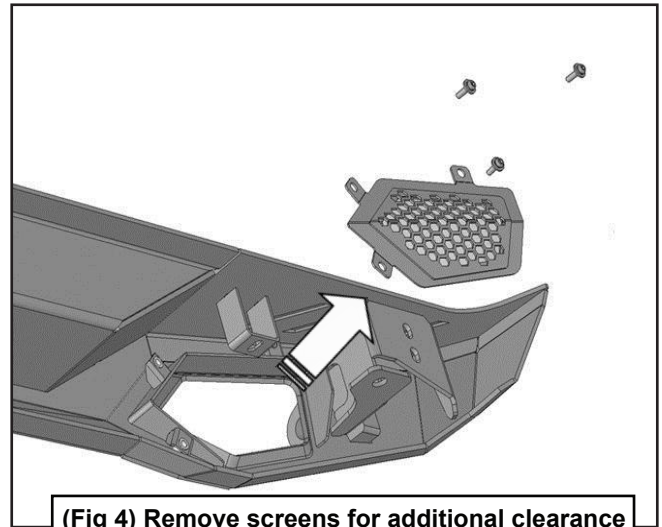

(Fig 4) Remove screens for additional clearance around lights (lights not included)

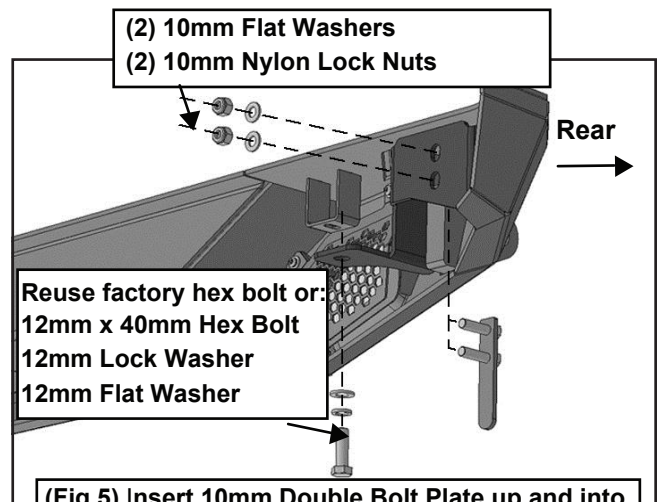

(Fig 5) Insert 10mm Double Bolt Plate up and into mounting tab on back of Bumper. Guide Bolt plate through tab and mounting plate on end of frame.

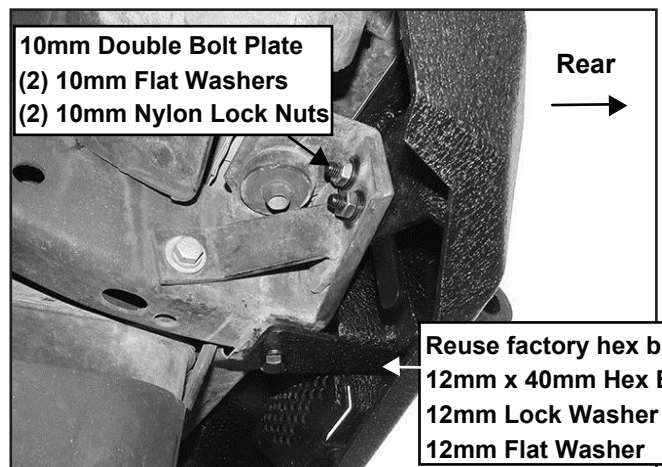

(Fig 6) Bumper installed (driver/left side pictured from below)