



## TYGER FURY™

TG-BP9J80098

### BEFORE INSTALLATION

READ INSTRUCTIONS CAREFULLY BEFORE STARTING INSTALLATION. REMOVE CONTENTS FROM BOX AND VERIFY ALL PARTS ARE PRESENT. FAILURE TO IDENTIFY DAMAGE BEFORE INSTALLATION COULD LEAD TO A REJECTION OF ANY CLAIM. IF MISSING PARTS OR ANY DAMAGE FOUND, PLEASE TAKE A PICTURE FOR THE CLAIM PURPOSE.

### TORQUE VALUES

Fastener Size	Class 8.8 Torque (ft-lbs)	Class 10.9 Torque (ft-lbs)
6mm	6-7	6-7
8mm	15-16	22-23
10mm	31-32	44-45
12mm	54-55	78-79
14mm	87-88	125-126

### Parts List

- x1 TYGER Rear Bumper
- x2 Support Brackets/12mm Double Nut Plates
- x4 12-1.75mm x 35mm Hex Bolts
- x4 12mm x 37mm x 3mm Flat Washers
- x4 12mm Lock Washers
- x4 10-1.5mm x 30mm Hex Bolts
- x4 10mm Lock Washers
- x4 10mm x 24mm x 2.2mm Flat Washers
- x1 4mm Allen Wrench

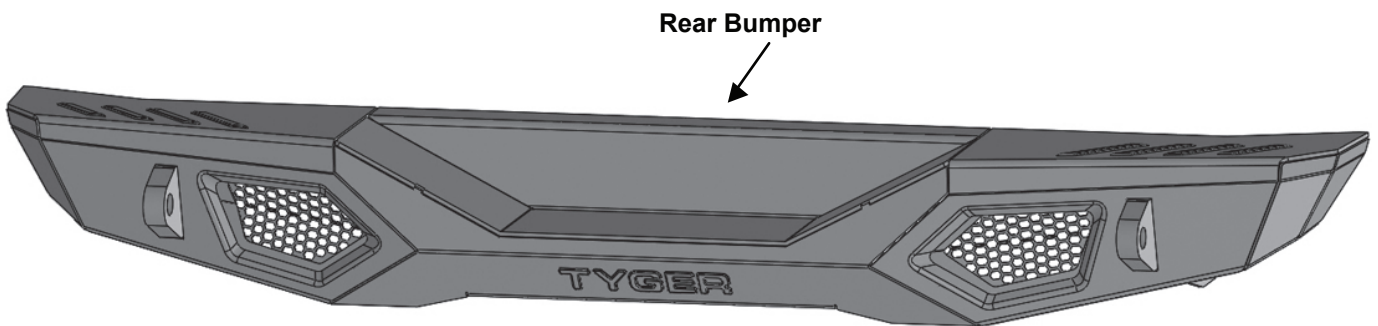

(2) 12mm Nut Plates





**WARNING:**

Allow time for the muffler to completely cool before removing rear bumper.

## STEP 1

Remove the factory bumper by removing the side brackets, (Fig 1), and the two inner brackets behind the factory bumper, (Fig 2).

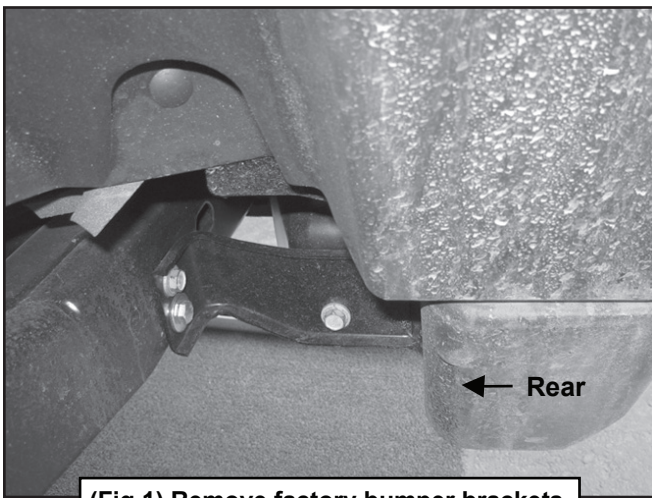

(Fig 1) Remove factory bumper brackets (Driver side pictured)

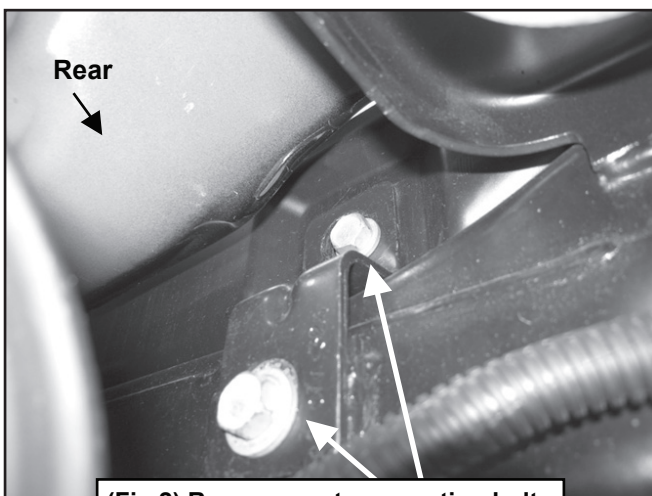

(Fig 2) Remove center mounting bolts behind bumper

## STEP 2

Insert (1) 12mm Double Nut Plate into the driver side frame channel and line up the threaded welded nuts with the (2) slots in the outside of the frame, (Figs 3-4).

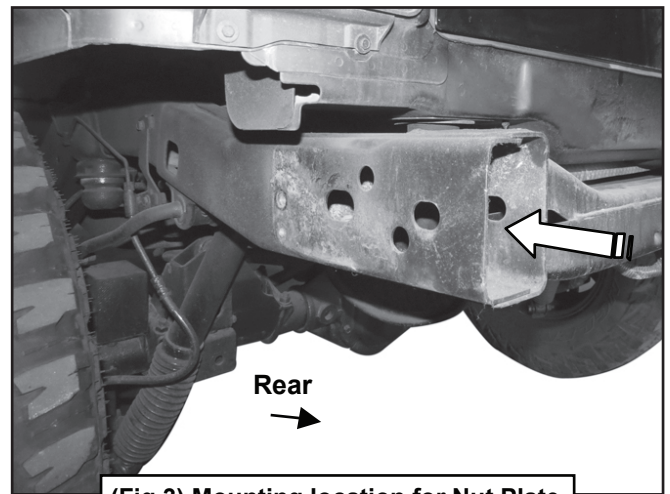

(Fig 3) Mounting location for Nut Plate (Driver side frame channel pictured)

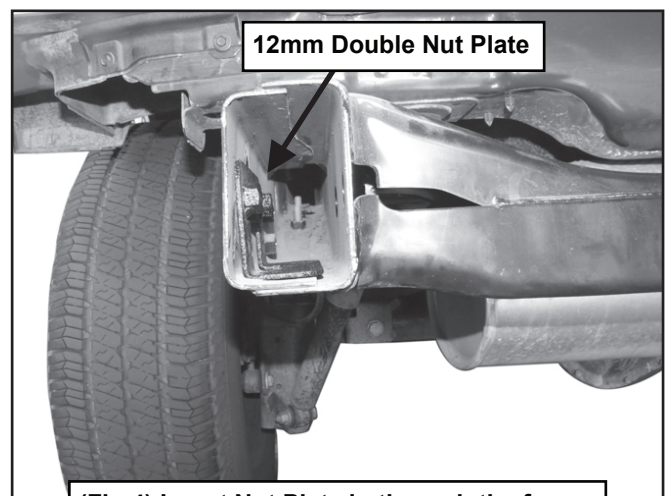

(Fig 4) Insert Nut Plate in through the frame channel (Driver side pictured)



## STEP 3

Repeat Step 2 to install (1) 12mm Double Nut Plate on the passenger side frame channel.

## STEP 4

**NOTE:** Cover the factory hitch, (if equipped), with a piece of cardboard or masking tape to protect the finish on the Rear Bumper.

## STEP 5

*If installing outer LED Lights, (not included):*

- a. Attach the LED Light to the mounting tab on the back of the Bumper. If necessary, remove the screen from the back of the Bumper to allow for adjustment, (Fig 5).
- b. Follow the light manufacturer's instructions to properly wire the lights.

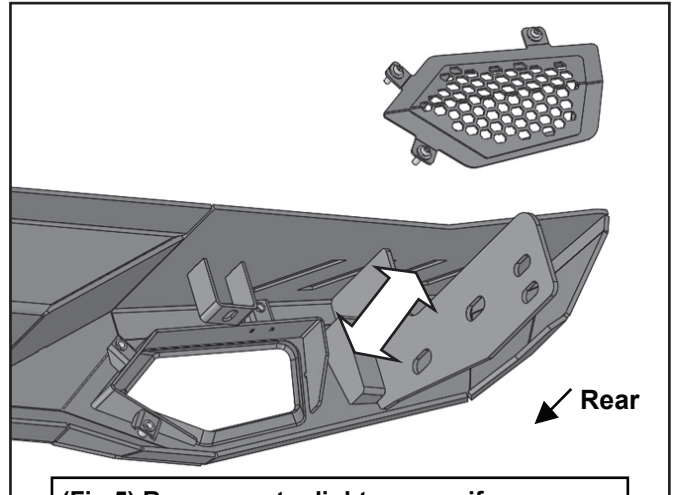

**(Fig 5) Remove outer light screen, if necessary to install light**



## STEP 6

With assistance, carefully position the Rear Bumper up to the outside of the frame. Attach the Bumper to the Nut Plates with the included (4) 12mm Hex Bolts, (4) 12mm Lock Washers and (4) 12mm Flat Washers, (Figs 6-8). Attach the Bumper to the threaded inserts in the sides of the frame using (4) 10mm Hex Bolts, (4) 10mm Lock Washers and (4) 10mm Flat Washers, (Figs 6-8). Do not tighten hardware at this time.

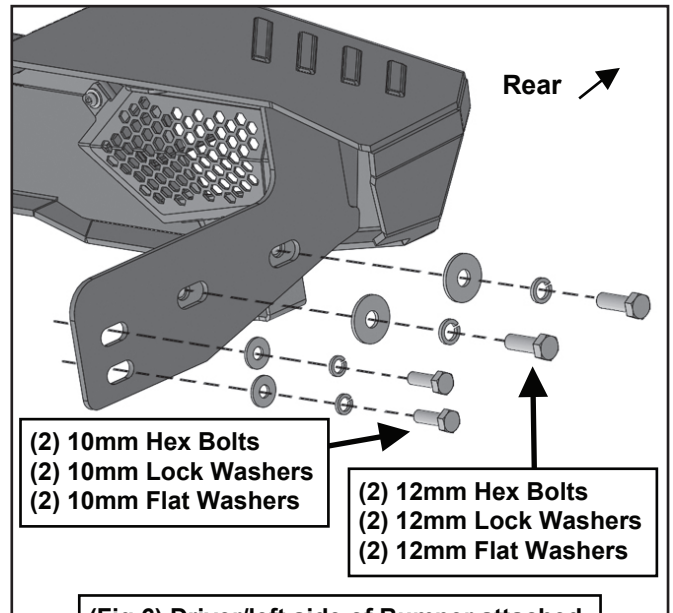

(Fig 6) Driver/left side of Bumper attached to the frame

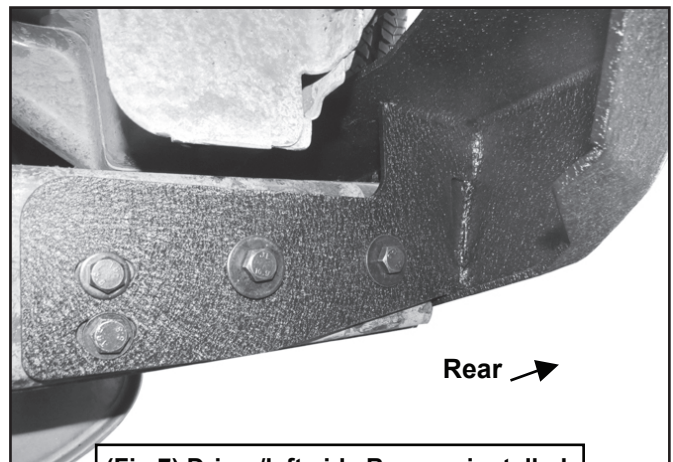

(Fig 7) Driver/left side Bumper installed

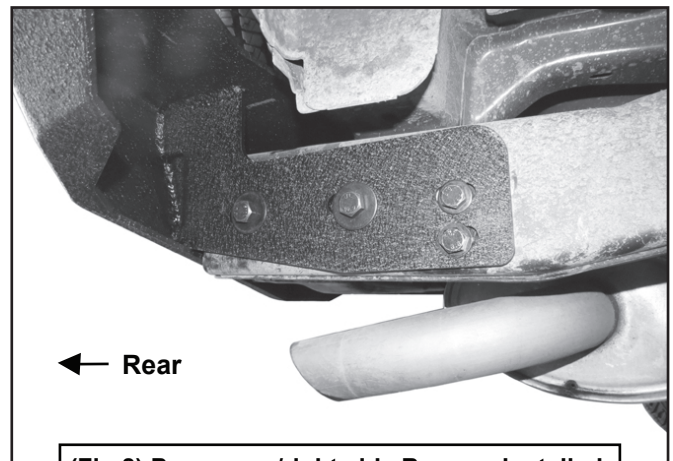

(Fig 8) Passenger/right side Bumper installed



# TYGER<sup>®</sup>

## STEP 7

Level and adjust the Rear Bumper and tighten all hardware at this time.

**NOTE:** If vehicle is equipped with factory tow hitch, leave a 1/4" gap between the Rear Bumper and the hitch.

## STEP 8

Do periodic inspections to the installation to make sure that all hardware is secure and tight.



**Complete Installation**