



FRONT BUMPER

TG-BP6J85368

BEFORE INSTALLATION

READ INSTRUCTIONS CAREFULLY BEFORE STARTING INSTALLATION. REMOVE CONTENTS FROM BOX AND VERIFY ALL PARTS ARE PRESENT. FAILURE TO IDENTIFY DAMAGE BEFORE INSTALLATION COULD LEAD TO A REJECTION OF ANY CLAIM. IF MISSING PARTS OR ANY DAMAGE FOUND, PLEASE TAKE A PICTURE FOR THE CLAIM PURPOSE.

TORQUE VALUES

Fastener Size	Class 8.8 Torque (ft-lbs)	Class 10.9 Torque (ft-lbs)
6mm	6-7	6-7
8mm	15-16	22-23
10mm	31-32	44-45
12mm	54-55	78-79
14mm	87-88	125-126

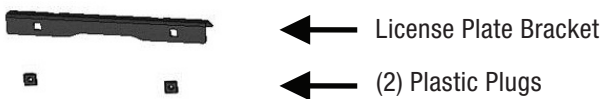
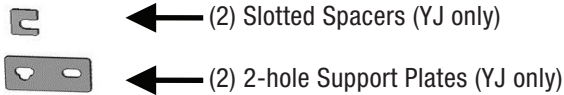
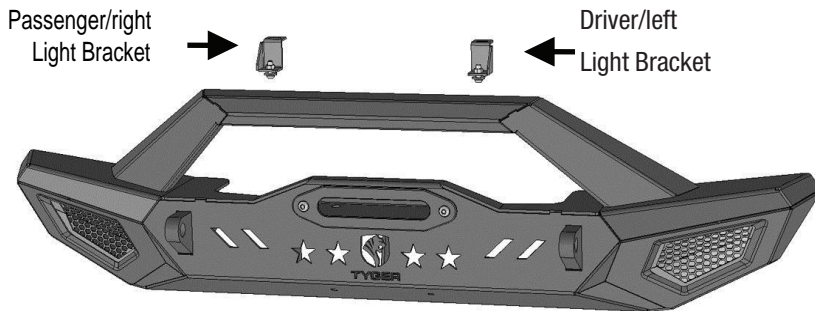

Parts List

- x1 TYGER Front Bumper w-cable guide
- x2 2-Hole Support Plate
- x2 Slotted Spacers
- x1 Driver/left Light Bracket
- x1 Passenger/right Light Bracket
- x1 License Plate Bracket
- x2 Plastic Plugs for License Plate
- x6 1/2" x 1.25"-13 Hex Bolts
- x6 1/2" Flat Washers
- x6 1/2" Lock Washers
- x2 8-1.25mm x 25mm Button Head Bolts
- x2 8mm x 24mm x 2mm Flat Washers
- x2 8mm Lock Washers
- x2 6-1.0mm x 20mm Button Head Bolts
- x4 6mm x 18mm x 1.6mm Flat Washers
- x2 6mm Nylon Lock Nuts
- x1 S=5mm Wrench (for 8mm Button Head Bolts)
- x1 S=4mm Wrench (for 6mm Button Head Bolts)



PROCEDURE: REMOVE CONTENTS FROM BOX. VERIFY ALL PARTS ARE PRESENT. READ INSTRUCTIONS CAREFULLY BEFORE STARTING INSTALLATION. ASSISTANCE IS RECOMMENDED. CUTTING MAY BE REQUIRED.

STEP 1

Start under the front bumper of the vehicle and remove the (2) button head T-55 torx bolts attaching the bumper to the bottom of the frame, (Figure 1).

IMPORTANT: Factory bolts may be very tight or rusted in place. Use of penetrating lubricant is highly recommended before attempting to remove hardware.

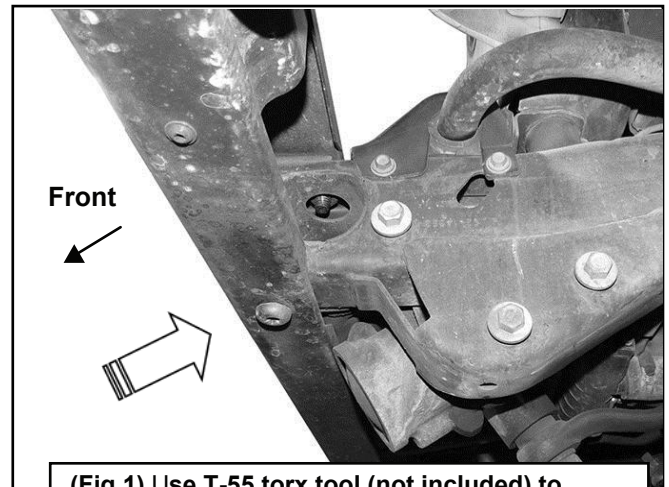

(Fig 1) Use T-55 torx tool (not included) to remove bumper bolts from bottom of bumper (arrow). TJ model pictured from below

STEP 2

Move to the top of the bumper. With assistance, remove the (4) bolts attaching the bumper to the top of the frame, (Figure 2).

NOTE: Bolts may also be used to attach tow hooks to the top of the bumper, remove bolts and tow hooks if equipped. On 1996-06 TJ and LJ models, remove the plastic cover over the sway bar, (Figure 2).



(Fig 2) Remove bumper bolts from top of bumper (arrow). On TJ-LJ models, also remove plastic sway bar cover from frame

STEP 3

Determine correct procedure for your model.

1986-1995 YJ models.

- With assistance, slide bumper over end of frame, (Figure 3).
- Line up the top-forward mounting hole on back of bumper with mounting hole closest to end of the passenger/right side of the frame.

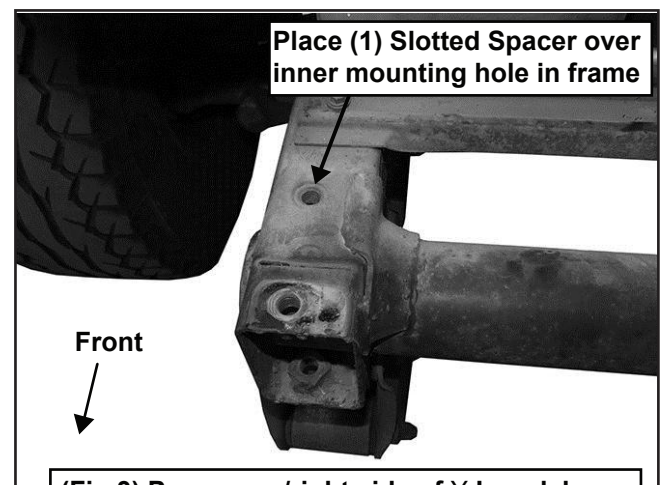

(Fig 3) Passenger/right side of YJ model frame with bumper removed



c. Place the small Slotted Spacer over top inner mounting hole, (Figures 3 & 4).

d. Place the long 2-hole Support Plate over the forward hole in the bumper, the slotted Spacer and (2) threaded holes in the frame, (Figure 4).

e. Insert (2) 1/2" Hex Bolts, (2) 1/2" Lock Washers and (2) 1/2" Flat Washers down through the 2-hole Support Plate, the Spacer, the Bumper and into the frame, (Figures 4 & 5). Leave loose.

f. Insert (1) 1/2" Hex Bolt, (1) 1/2" Lock Washer and (1) 1/2" Flat Washer up through the bottom mounting hole in the Bumper and into the frame, (Figures 4, 5 & 8). Leave loose.

g. Repeat the previous steps to attach the driver/left side of the Bumper to the frame.

1996-2006 TJ and LJ models

a. With assistance, slide bumper over the end of frame, (Figure 6).

b. Line up the (2) top mounting holes in the Bumper with the threaded mounting holes in the end of the passenger/right side of the frame.

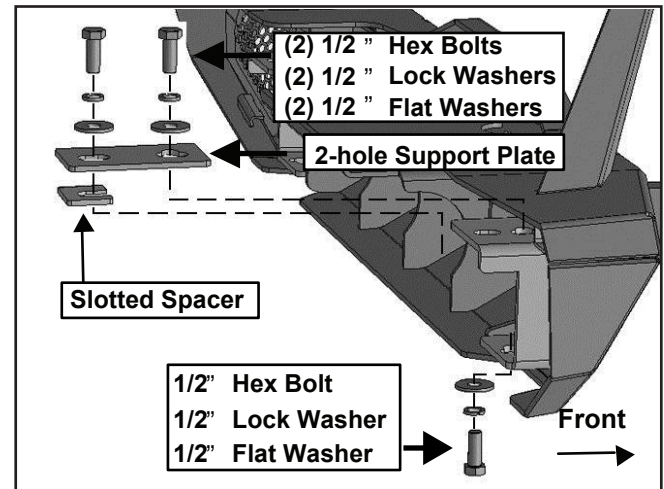

(Fig 4) On YJ models only, slide Bumper over end of frame. Place (1) Slotted Spacer over inner mounting hole on frame (see Fig. 3). Place 2-hole Support Plate over mounting tab on Bumper, Spacer and frame. pictured)

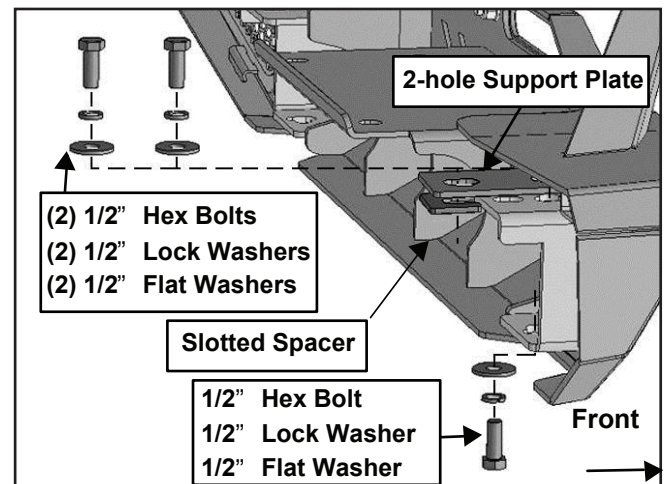

(Fig 5) On YJ models only, slide Bumper over end of frame. Place (1) Slotted Spacer over inner mounting hole on frame (see Fig. 3). Place 2-hole Support Plate over mounting tab on Bumper, Spacer and frame

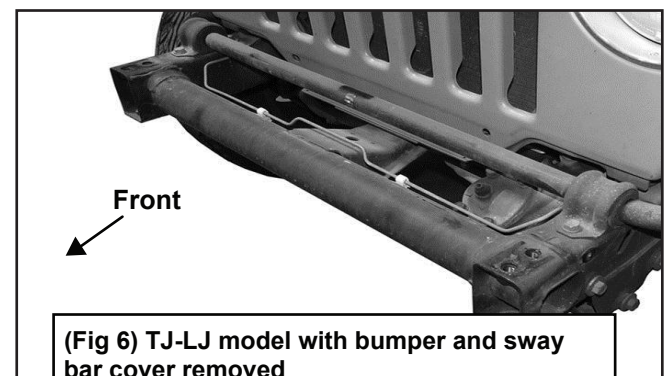

(Fig 6) TJ-LJ model with bumper and sway bar cover removed



TYGER[®]

c. Attach the top mounting plate on the bumper to the frame with the included (2) 1/2" Hex Bolts, (2) 1/2" Lock Washers and (2) 1/2" Flat Washers, (Figures 7 & 8). Leave loose at this time.

d. Insert (1) 1/2" Hex Bolt, (1) 1/2" Lock Washer and (1) 1/2" Flat Washer up through the bottom mounting hole in the bumper and into the frame, (Figures 7 & 9). Leave loose.

e. Repeat the previous steps to attach the driver/left side of the bumper to the frame.

f. With bumper in place, check the fit of the plastic sway bar cover and cut if necessary, to clear bumper.

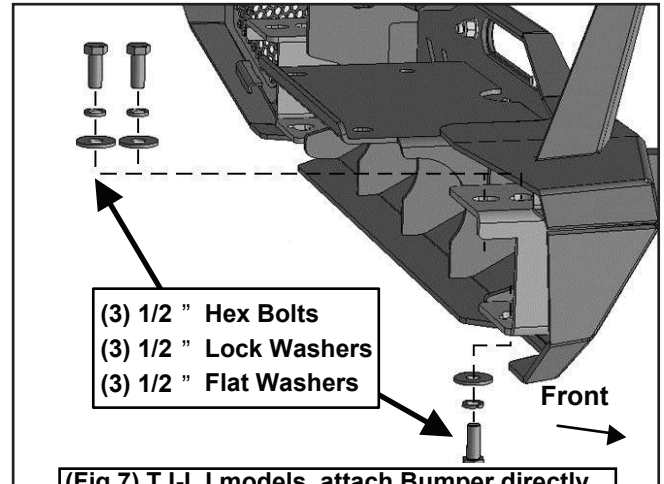

(Fig 7) TJ-LJ models, attach Bumper directly to top and bottom mounting holes in frame. No Spacers or Support Plates required

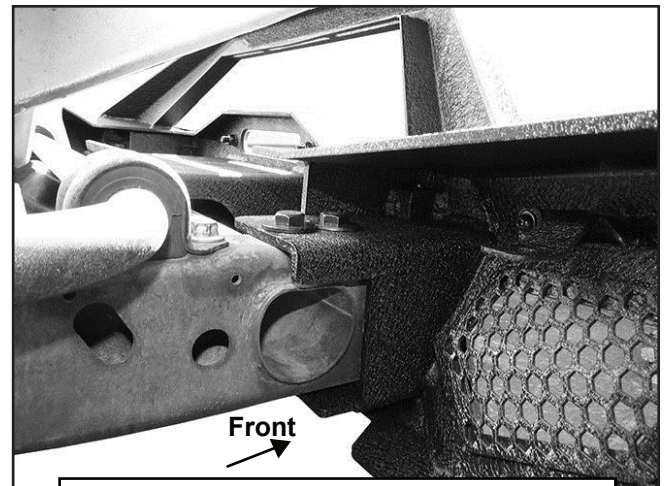

(Fig 8) TJ-LJ model with Bumper installed



(Fig 9) Passenger/right side TJ-LJ model pictured from below



STEP 4

Light bracket installation, (LED light not included).

- Select the left and right Light Brackets. Attach the Brackets to the slots in the back of the hoop on the Bumper with the included (2) 8mm x 25mm Button Head Bolts, (2) 8mm Lock Washers and (2) 8mm Flat Washers, (Figure 10). Leave hardware loose. NOTE: "L" Brackets are designed for 8mm light mounting hardware only. Modify "L" Brackets if necessary, to install hardware larger than 8mm.
- Next, attach lights or light bar, (not included), to the Brackets.
- Slide Brackets along slots as required to line up light with Bumper and tighten hardware.

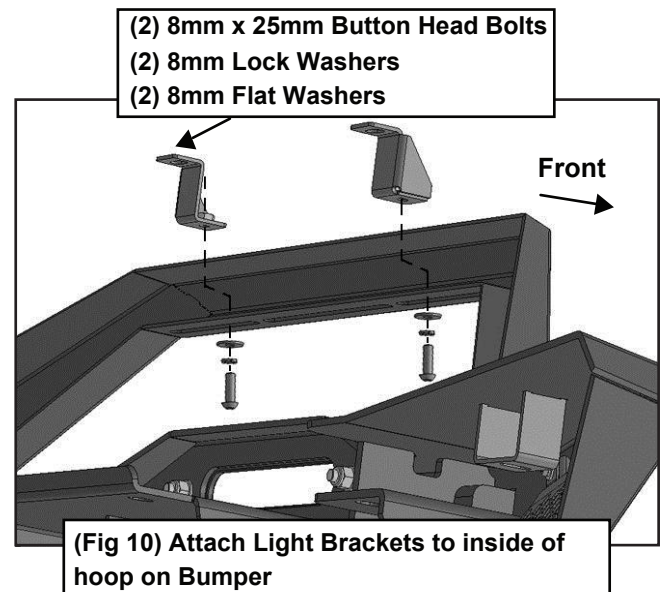

STEP 5

Winch Installation, (winch not included):

- Attach the winch to the top of the mounting plate behind the Bumper.
- Follow the manufacturer's instructions to properly attach the winch to the top of the bumper and to connect the winch to the electrical system. NOTE: As per winch instructions, never wind rope over top of the winch drum.

STEP 6

LED light installation at ends of bumper, (LED lights not included).

- Remove the screen from the back of the driver/left opening, (Figure 11).
- Attach light to mounting tab at top of opening. Check for clearance around light.
- Repeat the above Steps for passenger/right side light installation.
- Follow light manufacturer's instructions to adjust and properly wire the light to the vehicle electrical system.

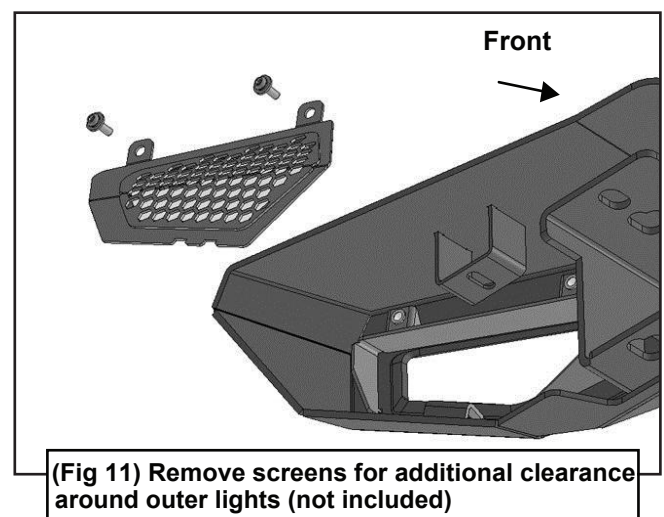



STEP 7

Select the License Plate Bracket. Attach the Bracket to the bottom of the bumper using (2) 6mm Button Head Bolts, (4) 6mm Flat Washers and (2) 6mm Nylon Lock Nuts, (Figure 12). Use the provided (2) Plastic Plugs to attach the License Plate to the front of the Bracket.

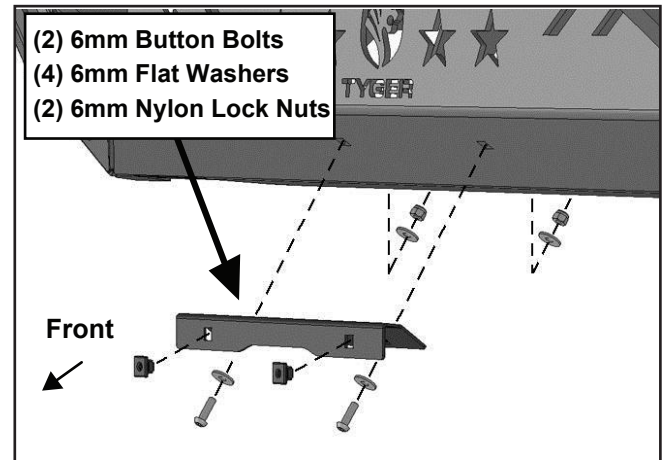

(Fig 12) License Plate Bracket attached to the bottom of the Bumper

STEP 8

Stand back from the vehicle and check to see that the Bumper is centered and level on the vehicle and adjust as required. Once properly aligned, fully tighten all hardware.



STEP 9

Do periodic inspections of the installation to make sure that all hardware is secure and tight.