



TYGER BLADE™

TG-BL8F7198

BEFORE INSTALLATION

READ INSTRUCTIONS CAREFULLY BEFORE STARTING INSTALLATION. REMOVE CONTENTS FROM BOX AND VERIFY ALL PARTS ARE PRESENT. FAILURE TO IDENTIFY DAMAGE BEFORE INSTALLATION COULD LEAD TO A REJECTION OF ANY CLAIM. IF MISSING PARTS OR ANY DAMAGE FOUND, PLEASE TAKE A PICTURE FOR THE CLAIM PURPOSE.

Fastener Size	Class 8.8 Torque (ft-lbs)	Class 10.9 Torque (ft-lbs)
6mm	6-7	6-7
8mm	15-16	22-23
10mm	31-32	44-45
12mm	54-55	78-79
14mm	87-88	125-126

PARTS LIST

- x2 TYGER Blade Running Boards
- x6 Mounting Brackets
- x6 8 Double Bolt Plates
- x18 8mm Plastic Retainers
- x48 8mm Lock Washers
- x24 8mm x 24mm x 2mm Flat Washers
- x12 8mm Hex Nuts
- x12 8mm Nylon Lock Nut

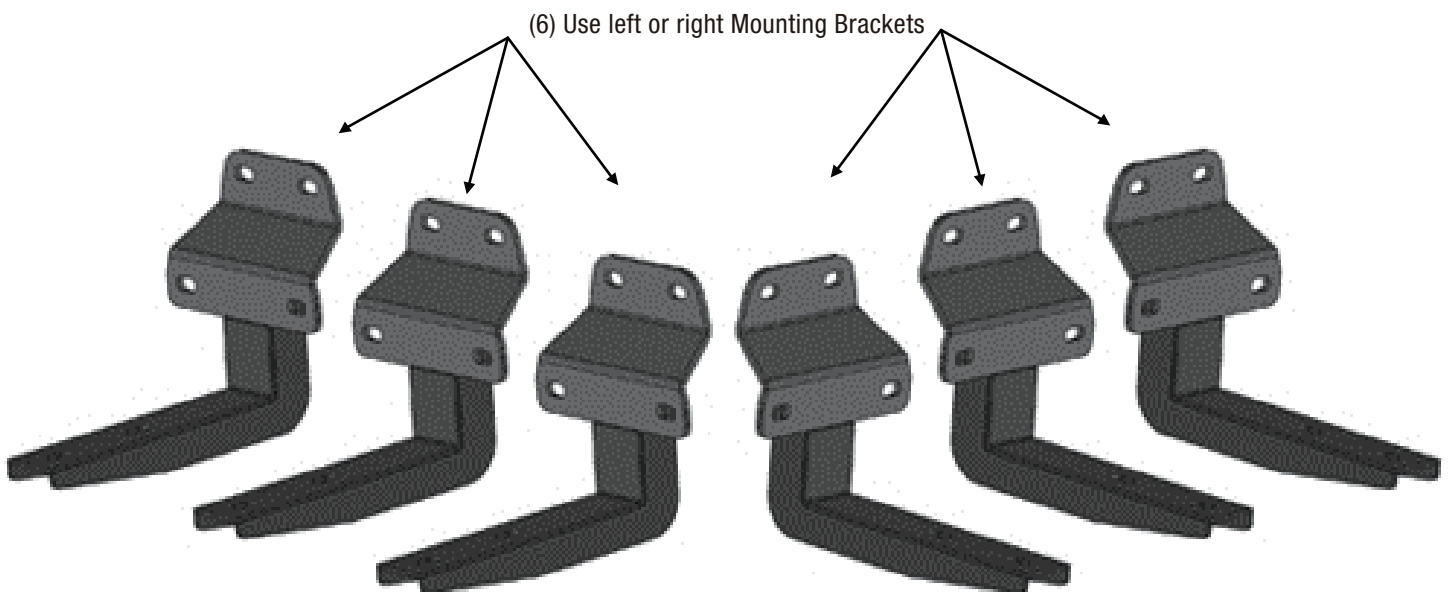



PROCEDURE

REMOVE CONTENTS FROM BOX. VERIFY ALL PARTS ARE PRESENT. READ INSTRUCTIONS CAREFULLY BEFORE STARTING INSTALLATION.

STEP 1

Starting on the driver front side of the body panel, locate the threaded mounting studs, (Figures 2, 5 & 6). Clean mounting studs with wire brush to remove paint and debris.

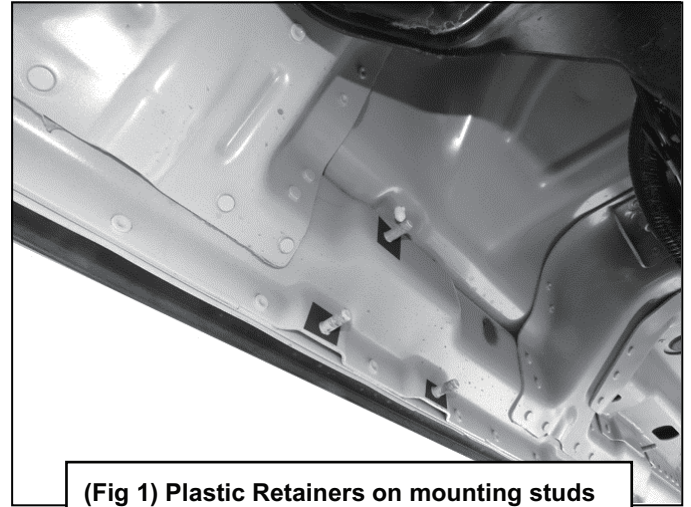

STEP 2

Slide (1) Plastic Washer over each of the (3) factory mounting studs in the body panel, (Figures 1—7). **IMPORTANT:** The Plastic Washers are designed to prevent corrosion between the aluminum body panel and the steel mounting brackets. Do not install the Brackets without the Plastic Washers.

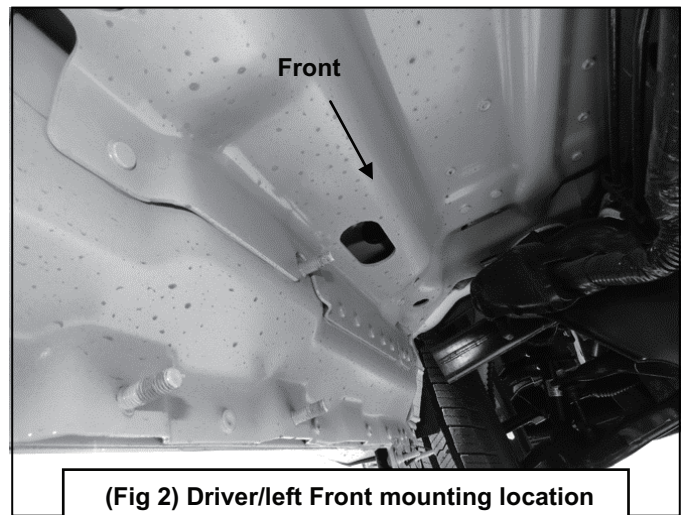

STEP 3

Select (1) Mounting Bracket. **NOTE:** All (6) Brackets are universal and will fit left or right side. Attach the Mounting Bracket to the (3) factory studs with (3) 8mm Flat Washers, (3) 8mm Lock Washer and (3) 8mm Hex Nuts, (Figures 3 & 7). Leave brackets loose at this time.

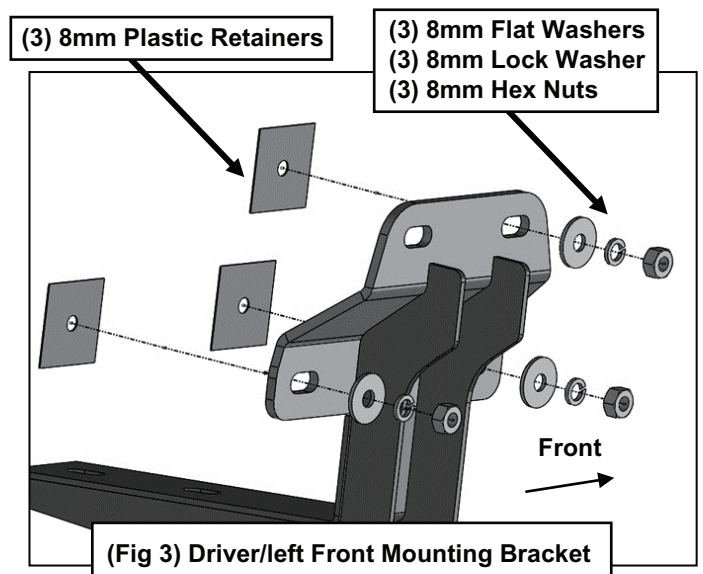



TYGER[®]

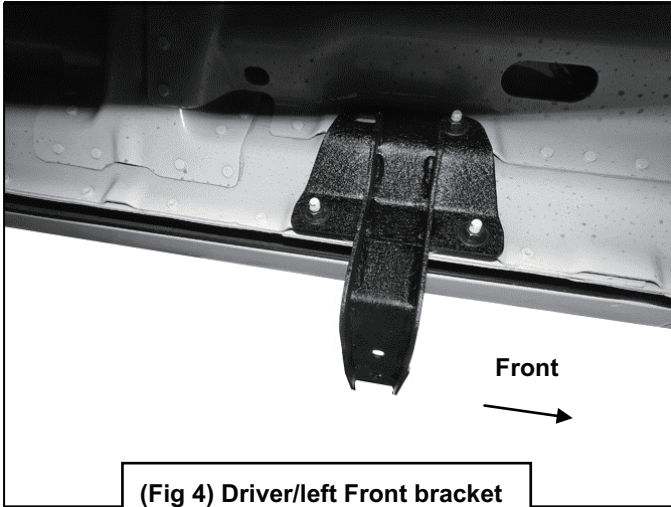

(Fig 4) Driver/left Front bracket

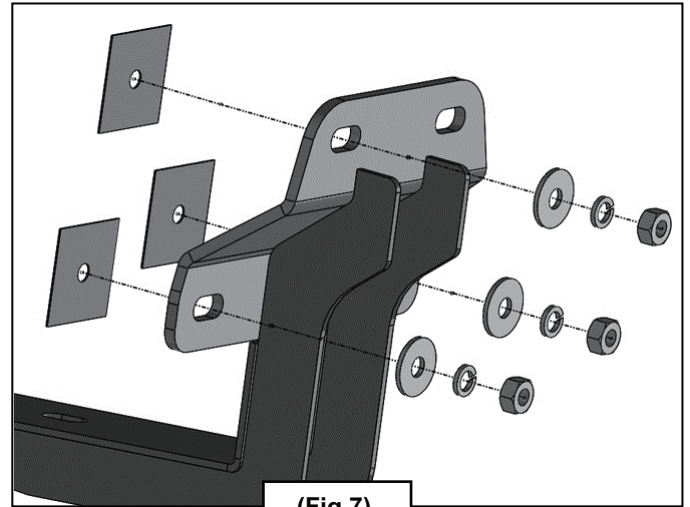

(Fig 7)

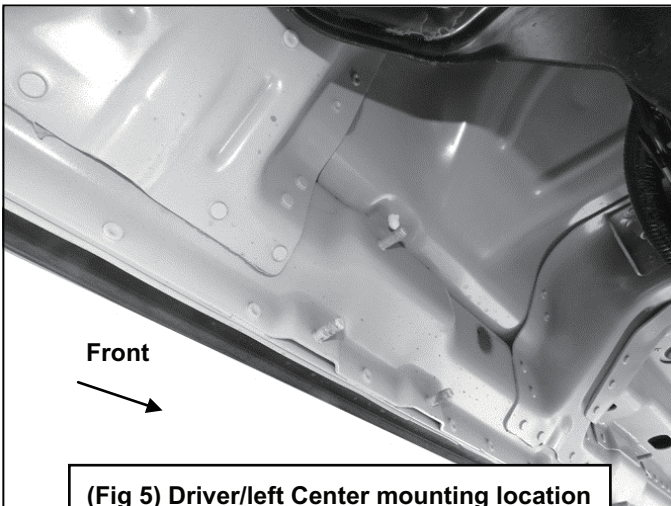

(Fig 5) Driver/left Center mounting location

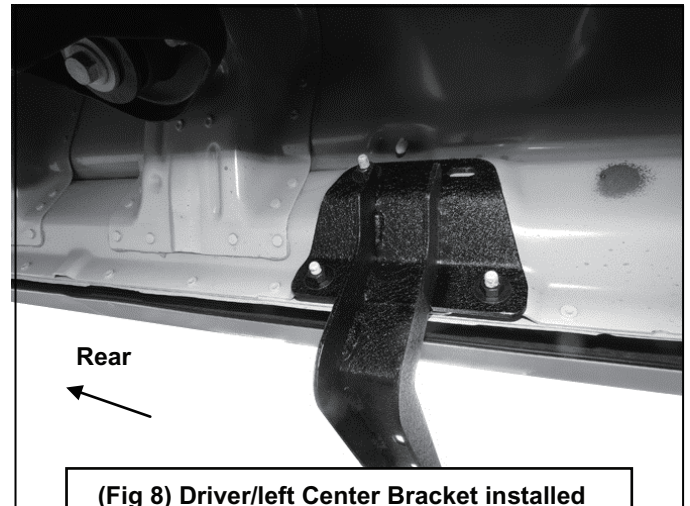

(Fig 8) Driver/left Center Bracket installed

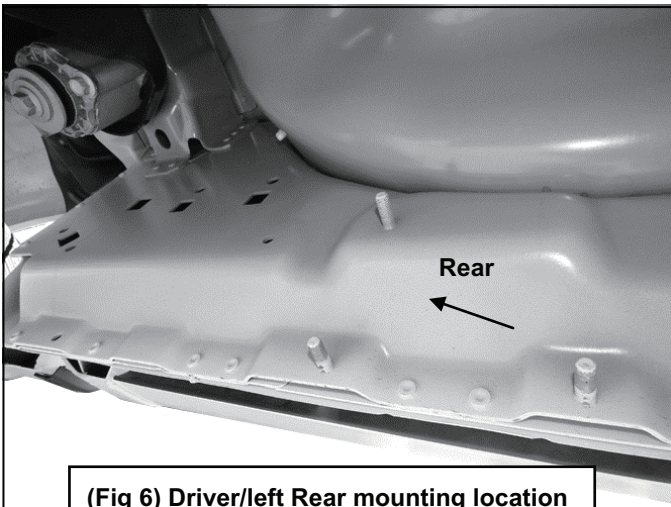

(Fig 6) Driver/left Rear mounting location

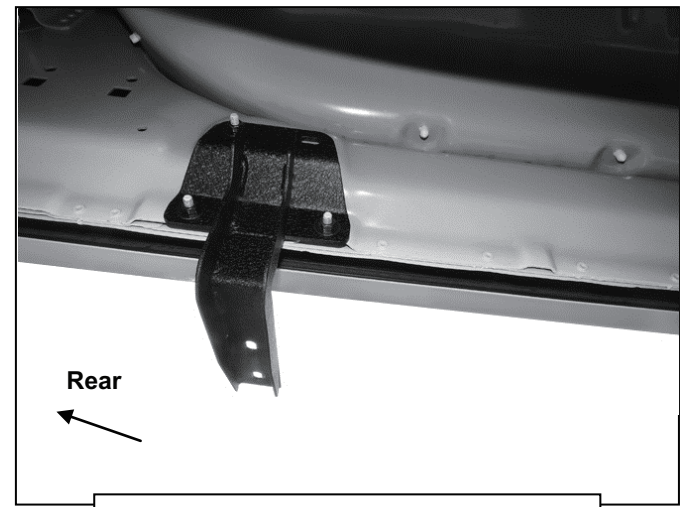

(Fig 9) Driver/left Center Bracket installed



TYGER[®]

STEP 4

Carefully unwrap (1) Running Board. Place the Running Board on top of the Brackets. Locate the channel in the bottom of the Running Board. Select (3) 8mm Double Bolt Plates, (Figure 10). Insert the Bolt Plates into the channel in the bottom of the Running Board closest to the Brackets. Lift the Running Board up and guide the studs down through the Brackets.

STEP 5

Attach the Running Board to the Brackets with (6) 8mm Flat Washers and (6) 8mm Nylon Lock Nuts, (Figure 11). NOTE: The Running Board is designed to fit close to the vehicle. It may be necessary to loosen the Bracket hardware slightly and tilt the Brackets downward to insert the Running Board between the Brackets and the body.

STEP 6

Level and adjust the Running Board as necessary and fully tighten all hardware.

STEP 7

Repeat Steps 2—7 for passenger/right side Running Board installation.

STEP 8

Do periodic inspections to the installation to make sure that all hardware is secure and tight.

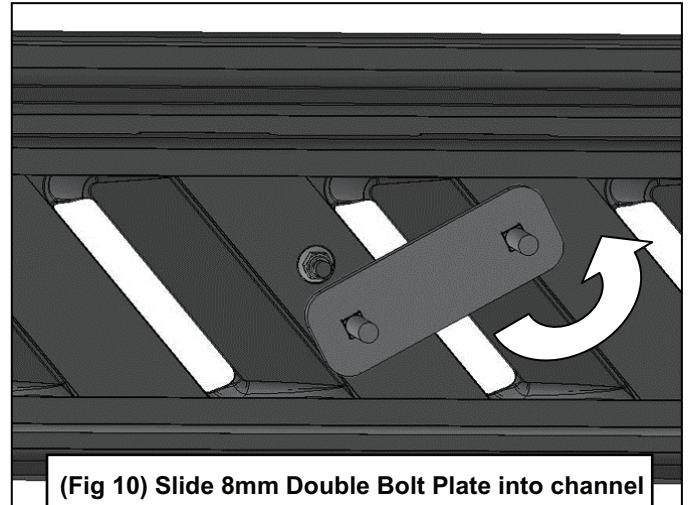

(Fig 10) Slide 8mm Double Bolt Plate into channel

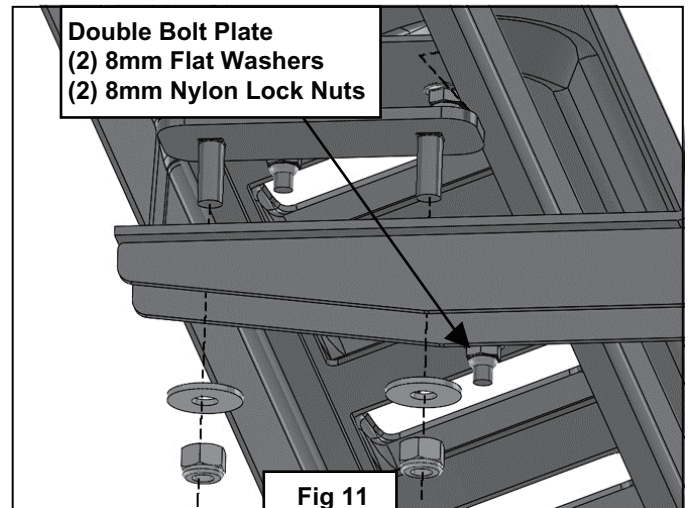
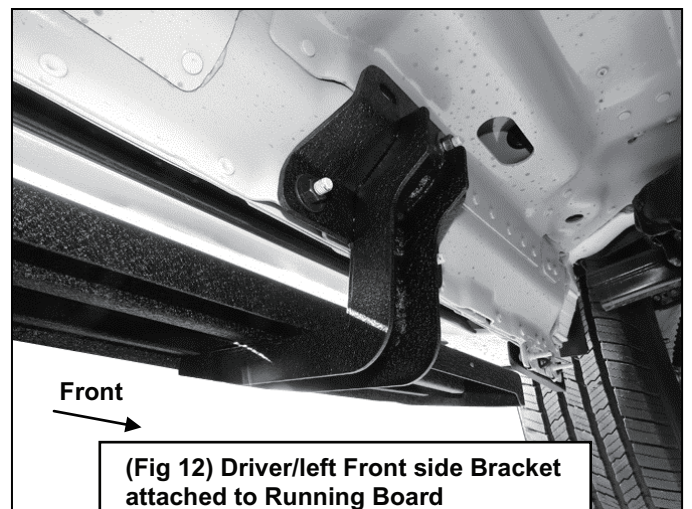

Fig 11



(Fig 12) Driver/left Front side Bracket attached to Running Board

To protect your investment, Do not use any type of polish or wax that may contain abrasives that could damage the finish. Mild soap may be used to clean the Running Board.

Learn more about running boards and step bars we have.