



# TYGER®

## TYGER BLADE™

TG-BL8D7168

### BEFORE INSTALLATION

READ INSTRUCTIONS CAREFULLY BEFORE STARTING INSTALLATION. REMOVE CONTENTS FROM BOX AND VERIFY ALL PARTS ARE PRESENT. FAILURE TO IDENTIFY DAMAGE BEFORE INSTALLATION COULD LEAD TO A REJECTION OF ANY CLAIM. IF MISSING PARTS OR ANY DAMAGE FOUND, PLEASE TAKE A PICTURE FOR THE CLAIM PURPOSE.

Fastener Size	Class 8.8 Torque (ft-lbs)	Class 10.9 Torque (ft-lbs)
6mm	6-7	6-7
8mm	15-16	22-23
10mm	31-32	44-45
12mm	54-55	78-79
14mm	87-88	125-126

### PARTS LIST

- x2 TYGER Blade Running Boards
- x2 Driver Front & Passenger Rear Bracket
- x2 Passenger Front & Driver Rear Bracket
- x1 Driver/left side Center Bracket
- x1 Passenger/right side Center Bracket
- x6 8-1.25mm Bolt/Nut Plates
- x6 8-1.25mm Double Bolt Plates
- x6 8mm Plastic Retainers
- x12 8-1.25mm x 30mm Hex Bolts
- x24 8mm x 24mm x 2mm Flat Washers
- x12 8mm Lock Washers
- x6 8-1.25mm Hex Nuts
- x12 8-1.25mm Nylon Lock Nuts
- x12 6-1.0mm x 25mm Button Head Bolts
- x24 6mm x 18mm x 1.6mm Flat Washers
- x12 6-1.0mm Lock Washers
- x12 6mm Hex Nuts
- x1 6mm Allen Wrench

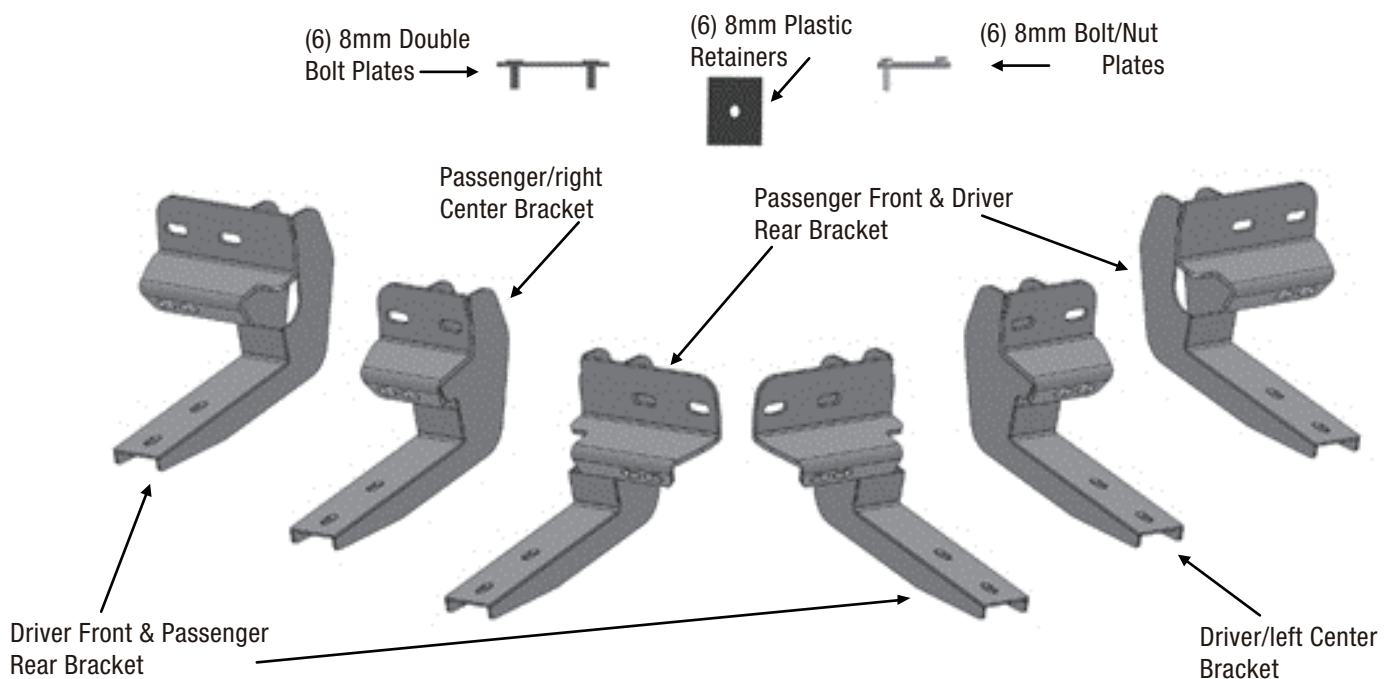



# TYGER<sup>®</sup>

## PROCEDURE

REMOVE CONTENTS FROM BOX. VERIFY ALL PARTS ARE PRESENT. READ INSTRUCTIONS CAREFULLY BEFORE STARTING INSTALLATION. DRILLING MAY BE REQUIRED.

### STEP 1

Starting at the driver front side of the vehicle, remove the sealing tape covering the factory holes in the side of the inner panel, (Figure 1).

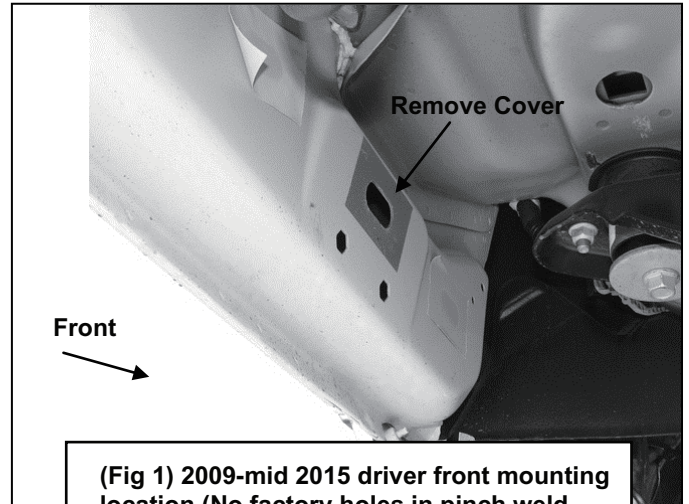

(Fig 1) 2009-mid 2015 driver front mounting location (No factory holes in pinch weld 2009-2012 models)

### STEP 2

Determine the correct procedure to attach the driver/left side Front Bracket for your model/year:

Models without factory threaded inserts in body panel, (see Figure 1):

- Select (1) 8mm Bolt-Nut Plate, (Figure 2). Partially thread an 8mm Hex Bolt into the threaded nut on the Bolt-Nut Plate, (Figure 3). Thread the Hex Bolt in until it is flush with the welded nut. Use the Hex Bolt as a handle and insert the Bolt-Nut Plate into the oval hole, (Figure 4). Feed the threaded bolt on the Bolt-Nut Plate through one of the hex shaped factory holes.
  - Thread (1) 8mm Plastic Retainer onto the threaded end and down tight against the body panel, (Figure 5). NOTE: The Plastic Retainer is designed to keep the Bolt-Nut Plate from falling into the body panel and to aid in Bracket installation.
  - Select the driver/left side Front Bracket, (Figure 6). Attach the Bracket to the threaded end of the Bolt Plate with (1) 8mm Flat Washer, (1) 8mm Lock Washer and (1) 8mm Hex Nut, (Figure 7).
  - Remove the 8mm Hex Bolt from the nut on the Bolt Plate from Step 2a. Rotate the Bolt on the Bolt-Nut Plate until the threaded nut lines up with the remaining hole in the Bracket and hex hole in the body panel, (Figure 7). Attach the Bracket to the threaded nut with (1) 8mm x 30mm Hex Bolt, (1) 8mm Lock Washer and (1) 8mm Flat Washer, (Figure 7). Do not tighten hardware.
- Models with factory threaded inserts, (see Figure 8):
- Attach the driver/left side Front Bracket to the threaded inserts with (2) 8mm x 30mm Hex Bolts, (2) 8mm Lock Washers and (2) 8mm Flat Washers, (Figures 8 & 9). Leave hardware loose.

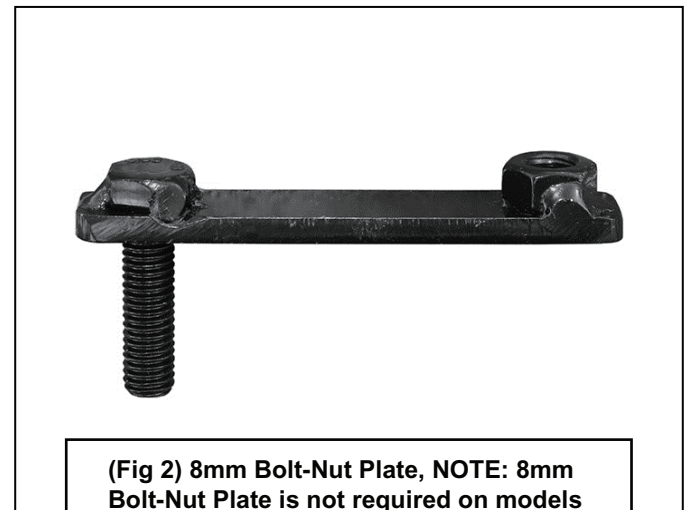

(Fig 2) 8mm Bolt-Nut Plate, NOTE: 8mm Bolt-Nut Plate is not required on models with threaded inserts

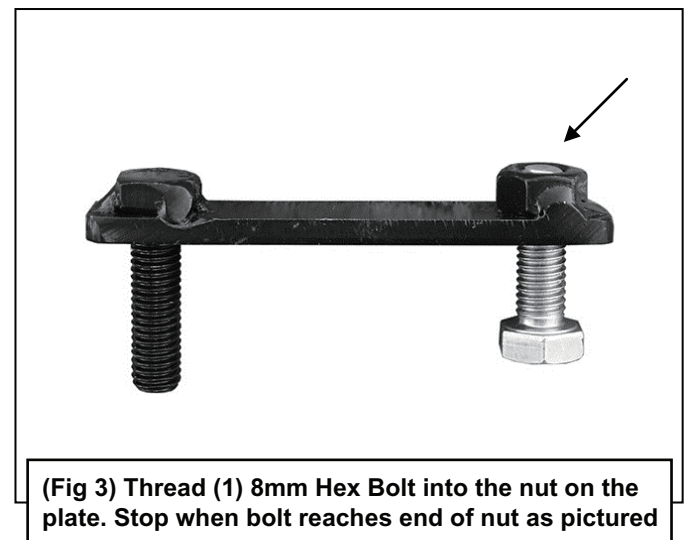

(Fig 3) Thread (1) 8mm Hex Bolt into the nut on the plate. Stop when bolt reaches end of nut as pictured



# TYGER<sup>®</sup>

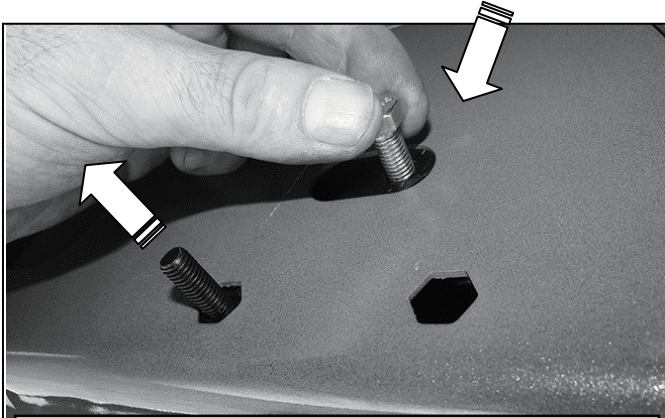

(Fig 4) Use the loose Hex Bolt as a handle. Insert the Bolt Plate into the oval hole and feed the threaded end out either factory hex shaped hole. **IMPORTANT:** Do not let go of the hex bolt until after Plastic Retainer has been threaded onto bolt (Fig 5)

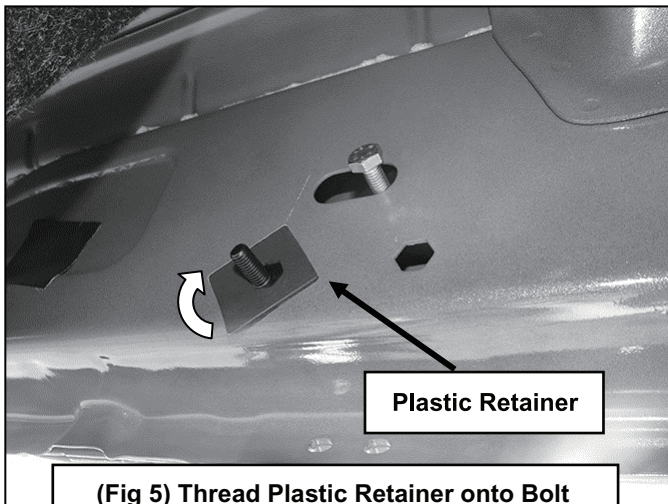

(Fig 5) Thread Plastic Retainer onto Bolt Plate to hold Bolt Plate in position.

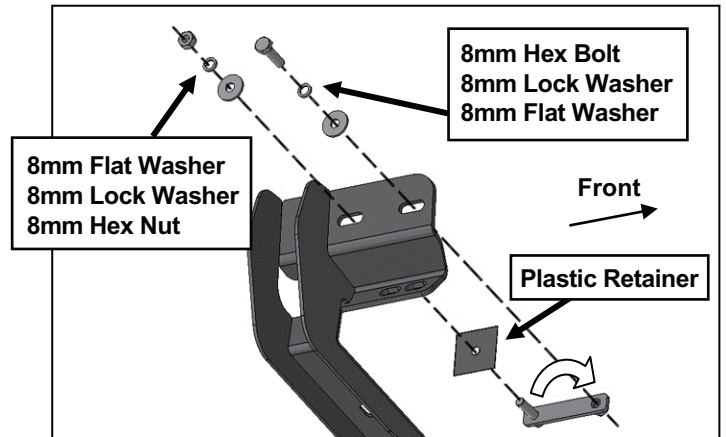
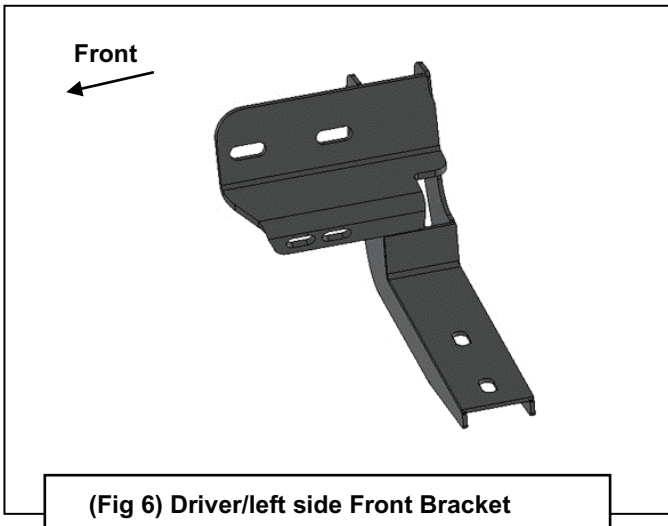

(Fig 7) Attach Bracket to threaded end of Bolt Plate. Remove 8mm Hex Bolt (see Fig 3). Rotate Bolt Plate to line up with remaining factory hex shaped hole.

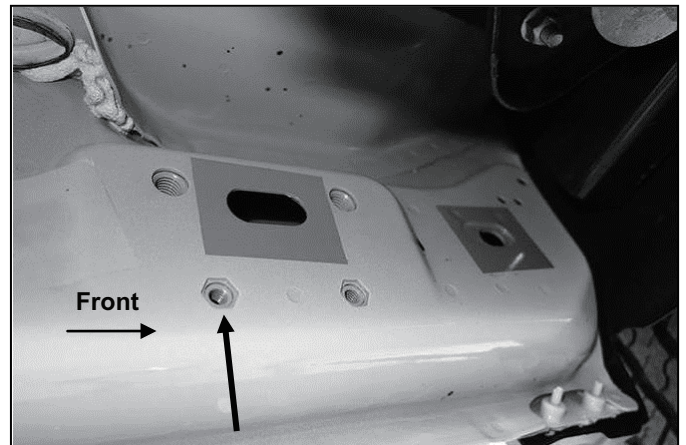

(Fig 8) Driver/left side front mid 2015-on (example of models with factory installed threaded inserts)

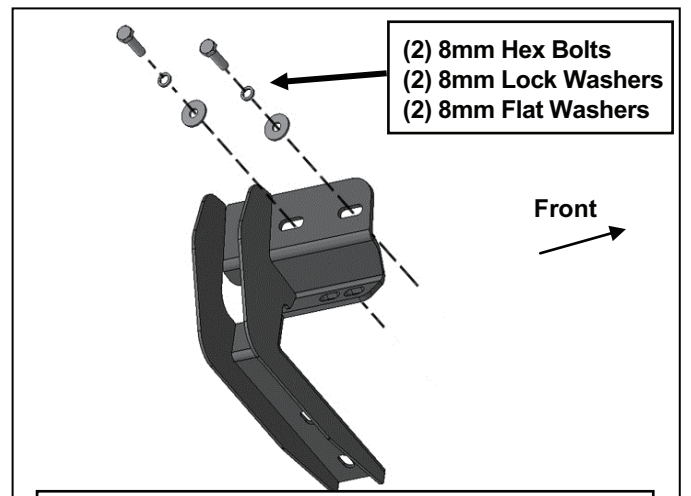

(Fig 9) Driver/left side front models with factory installed threaded inserts. Bolt Plate not required





# TYGER<sup>®</sup>

## STEP 3

Secure the Bracket to the back of the pinch weld with (2) 6mm Button Head Bolts, (4) 6mm Flat Washers, (2) 6mm Lock Washers and (2) 6mm Hex Nuts, (Figures 10 & 11). Do not fully tighten. **IMPORTANT:** Most 2009-12 models are not equipped with factory holes and will require drilling through the pinch weld to attach the Bracket. Do not drill through pinch weld at this time, (see Step 9).

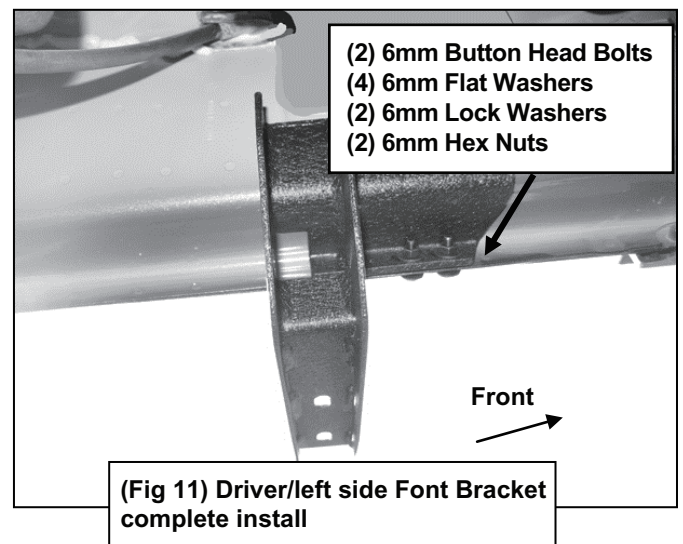
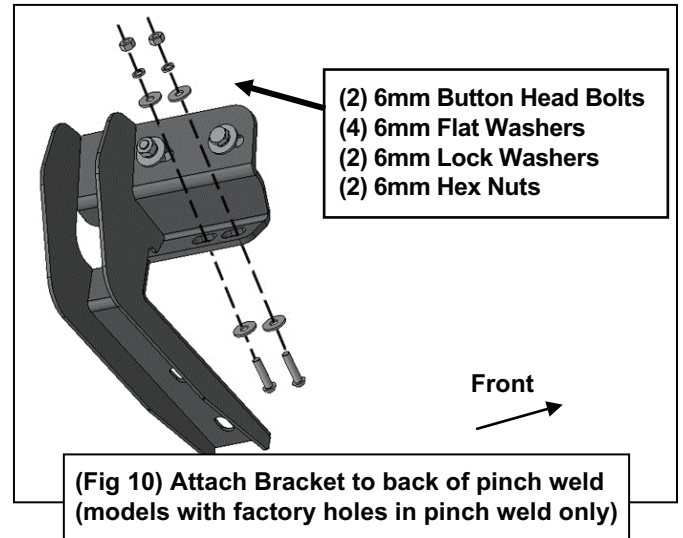

## STEP 4

Move along the side of the body panel to the center mounting location, (Figure 12). Repeat the appropriate Steps 1—3 to install the Driver/left side Center Bracket, (Figure 13).

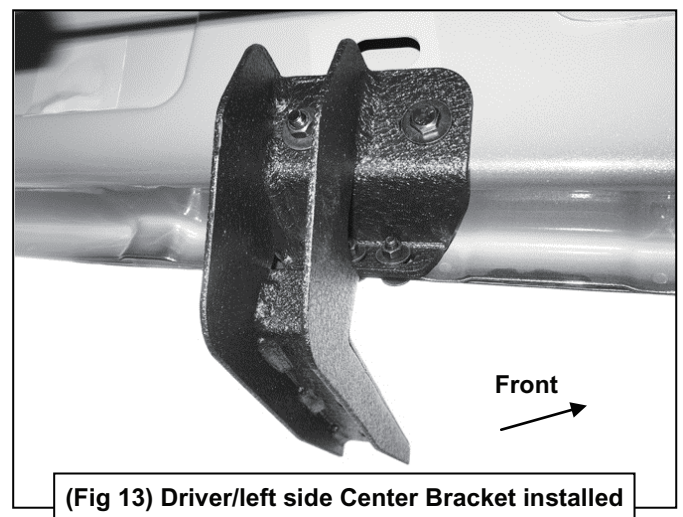
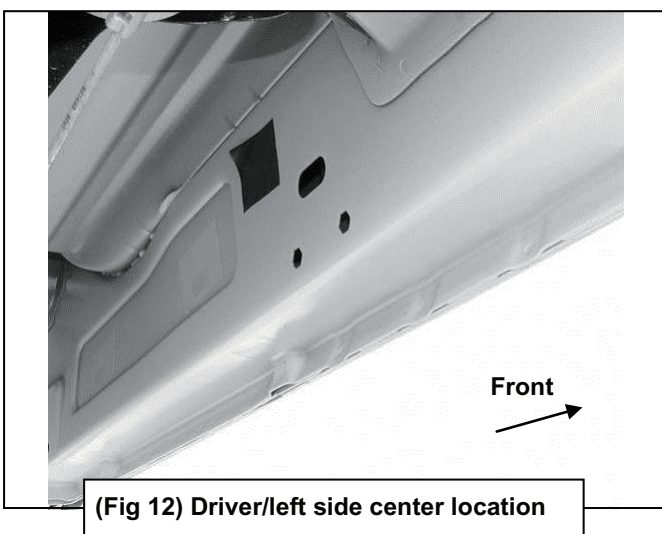



# TYGER®

## STEP 5

Move to the rear location, (Figure 14). Repeat the appropriate Steps 1—3 to install the Driver/left side Rear Bracket, (Figure 15).

## STEP 6

Once all Brackets have been fully installed, select (1) Running Board.

## STEP 7

Place the Running Board on top of the Brackets. Locate the channel in the bottom of the Running Board. Select (3) 8mm Double Bolt Plates. Insert the Bolt Plates into the channel in the bottom of the Running Board closest to the Brackets, (Figure 16). Lift the Running Board up and guide the studs down through the Brackets.

**IMPORTANT: 2009-2012 models without holes in pinch weld will require drilling 1/4" holes through pinch weld to attach the bracket. Do complete installation of Running Boards first, level Running Board before drilling holes for bracket.**

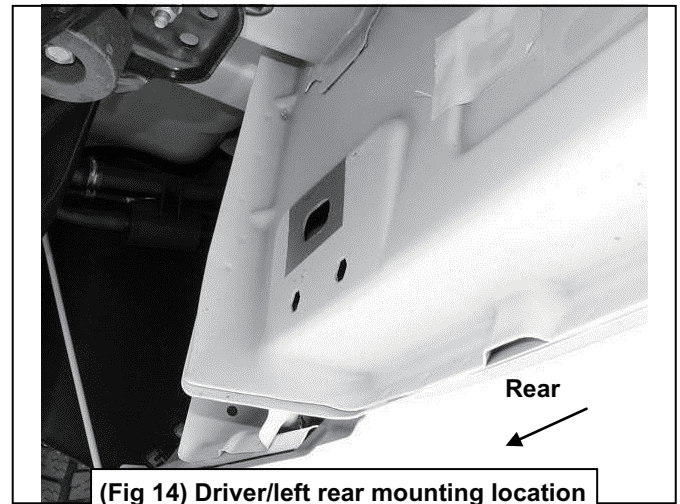

(Fig 14) Driver/left rear mounting location

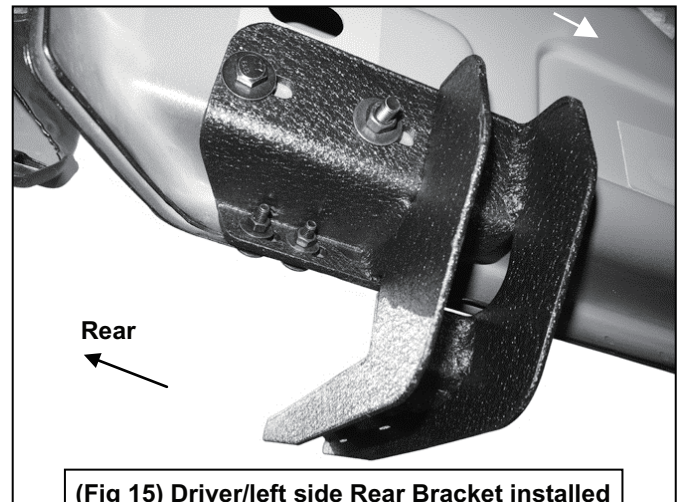

(Fig 15) Driver/left side Rear Bracket installed

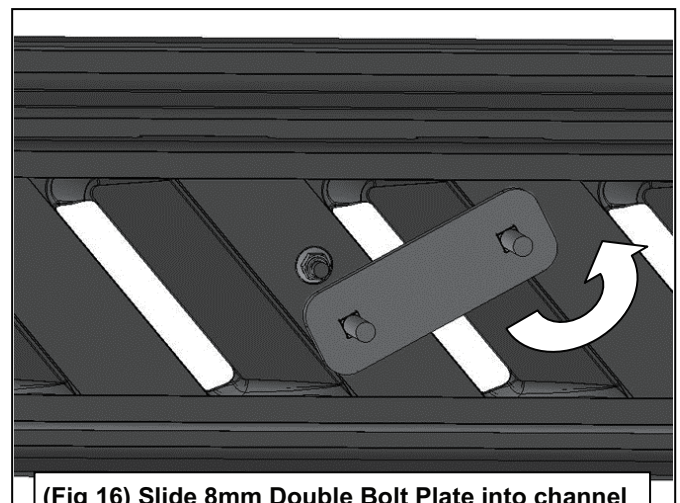

(Fig 16) Slide 8mm Double Bolt Plate into channel



# TYGER®

## STEP 8

Attach the Running Board to the Brackets with (6) 8mm Flat Washers and (6) 8mm Nylon Lock Nuts, (Figures 17 & 18). Do not tighten hardware at this time.

## STEP 9

Properly level and adjust the Running Board and fully tighten all hardware.

2009-12 models requiring drilling to attach Brackets to pinch weld:

- Level the Running Board to the vehicle. Make sure all (3) Brackets are tight against the bottom of the body panel and tighten all mounting hardware.
- Mark the location of the slots onto the pinch weld.
- Temporarily remove the Running Board and the (3) Mounting Brackets. Drill (2) 1/4" holes through the pinch weld for each Bracket. **IMPORTANT:** Do not drill too close to the bottom edge of the pinch weld. Drill the holes in the center of the marked slots.
- Repeat Step 4 to attach the Brackets to the drilled holes in the pinch weld. Check for level then fully tighten all hardware.

## STEP 10

Repeat Steps 1—9 for Running Board installation on the passenger.

## STEP 11

Do periodic inspections to the installation to make sure that all hardware is secure and tight.

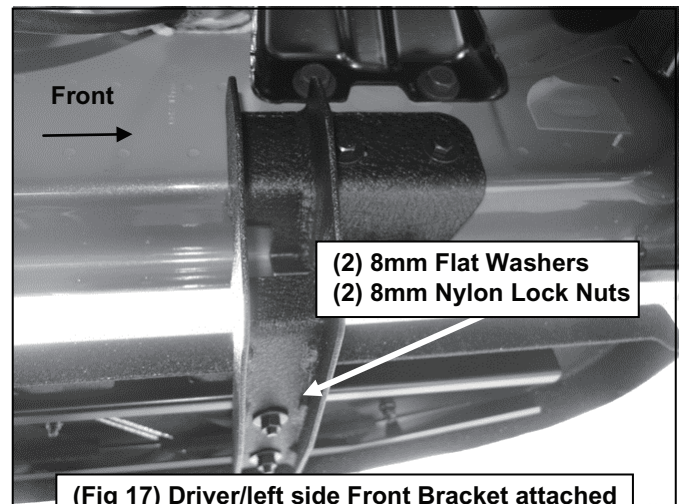

(Fig 17) Driver/left side Front Bracket attached to Running Board

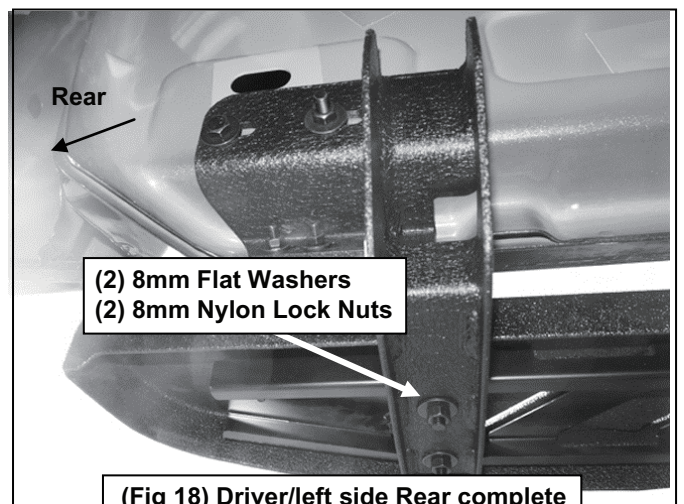

(Fig 18) Driver/left side Rear complete installation