



TYGER BLADE™

TG-BL2D7138

BEFORE INSTALLATION

READ INSTRUCTIONS CAREFULLY BEFORE STARTING INSTALLATION. REMOVE CONTENTS FROM BOX AND VERIFY ALL PARTS ARE PRESENT. ASSISTANCE IS RECOMMENDED.

Torque Value

Fastener Size	Class 8.8 Tightening Torque (ft-lbs)	Class 10.9 Tightening Torque (ft-lbs)
6mm	6-7	6-7
8mm	15-16	22-23
10mm	31-32	44-45
12mm	54-55	78-79
14mm	87-88	125-126

NOTE:
Assistance is recommended.

Parts List

- x2 Tyger Blade Running Boards
- x6 Mounting Brackets
- x6 8mm Double Bolt Plates
- x30 8mm x 24mm x 2mm Flat Washers
- x30 8-1.25mm Nylon Lock Nuts

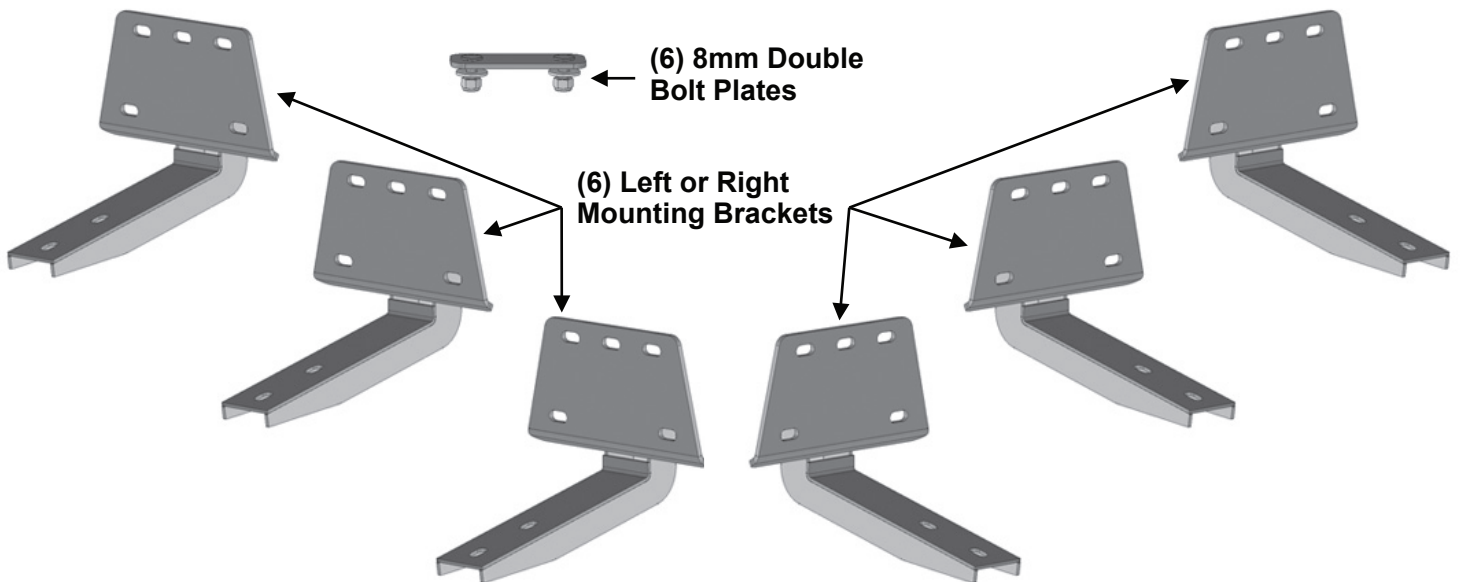



STEP 1

Start the installation under the passenger side of the vehicle. Locate the front (3) factory studs along the inner side of the body panel, (Fig 1).

IMPORTANT: Use a wire brush or thread chaser die to remove excess paint or undercoating from threaded studs as necessary.

STEP 2

Select (1) Mounting Bracket.

NOTE: All (6) Brackets are universal and will fit left or right side. Attach the Mounting Bracket to the (3) factory studs with (3) 8mm Flat Washers and (3) 8mm Nylon Lock Nuts, (Figs 2-3). Leave brackets loose at this time.

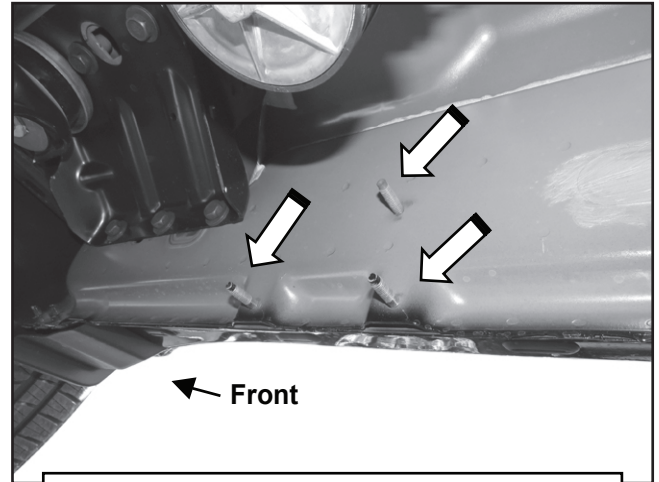

(Fig 1) Passenger/right front mounting location

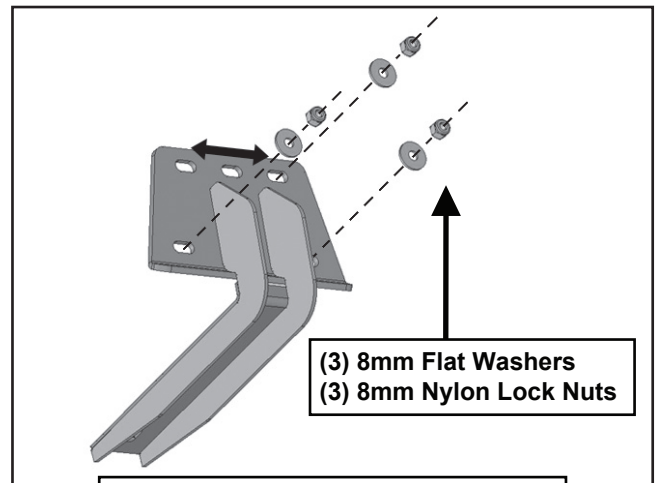

(Fig 2) Attach Bracket to the (3) studs

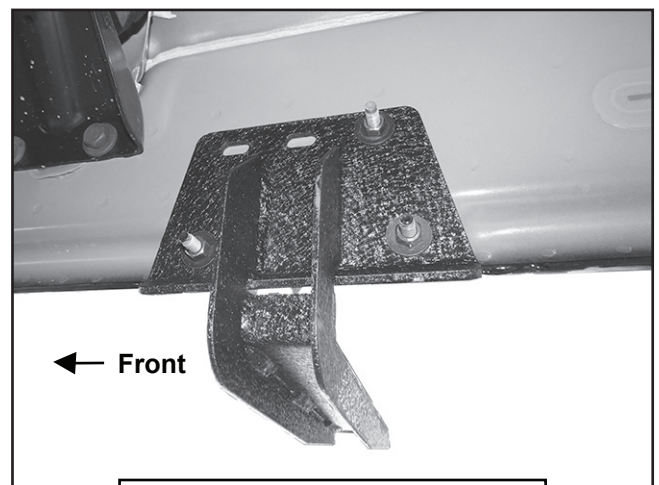

(Fig 3) Attach Mounting Bracket to passenger/right front location



STEP 3

Repeat Steps 1-2 to install the Mounting Brackets in the center and rear mounting locations along the body panel, (Figs 4-6).

STEP 4

Once all Brackets have been fully installed, select (1) Running Board.

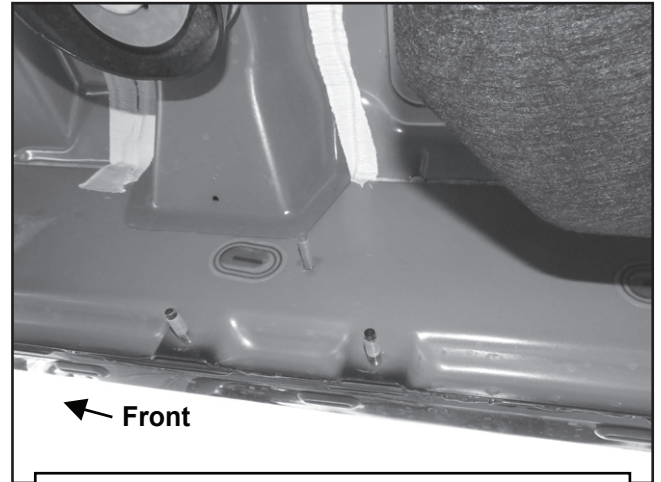

(Fig 4) Passenger/right center mounting location

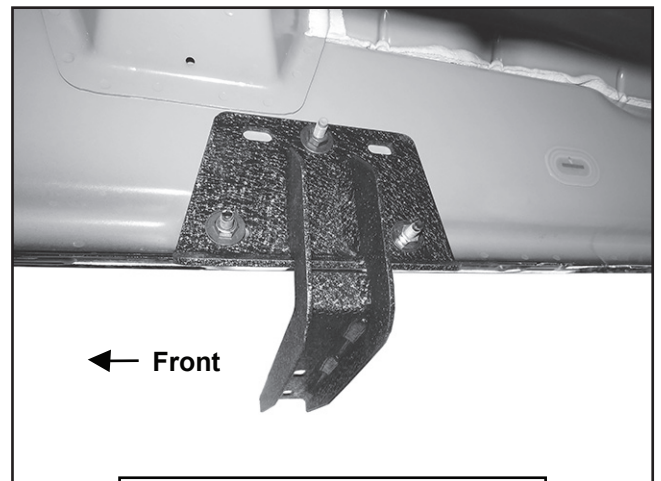

(Fig 5) Attach Mounting Bracket to passenger/right center location

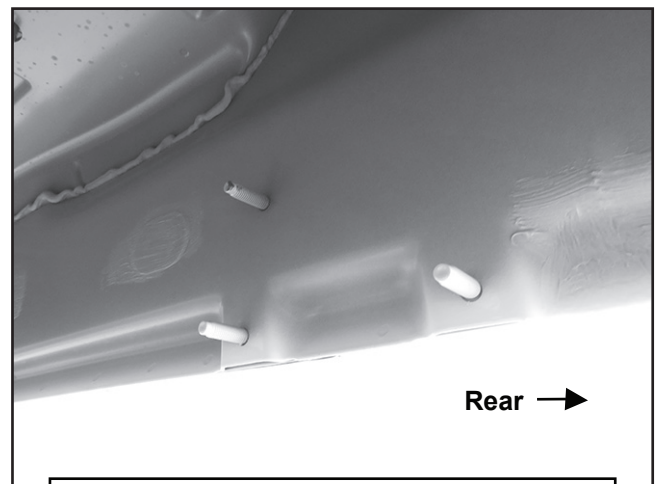

(Fig 6) Passenger/right rear mounting location



STEP 5

Place the Running Board on top of the Brackets. Locate the channel in the bottom of the Running Board. Select (3) 8mm Double Bolt Plates. Insert the Bolt Plates into the channel in the bottom of the Running Board closest to the Brackets, (Fig 7). Lift the Running Board up and guide the studs down through the Brackets.

STEP 6

Attach the Running Board to the Brackets with (6) 8mm Flat Washers and (6) 8mm Nylon Lock Nuts, (Figs 8-9). Do not tighten hardware at this time.

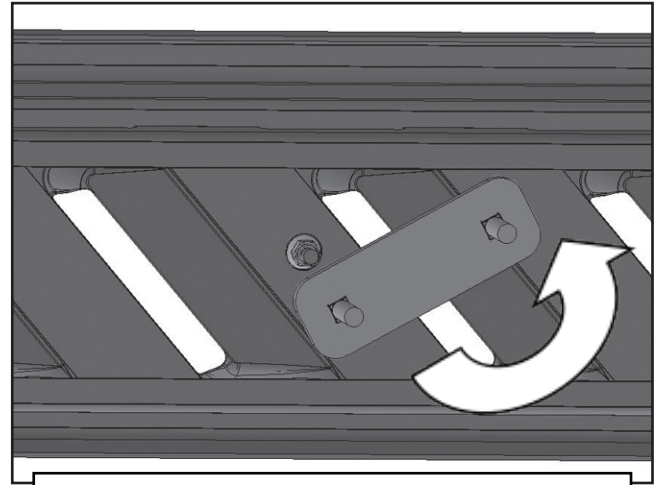

(Fig 7) Slide 8mm Double Bolt Plate into channel

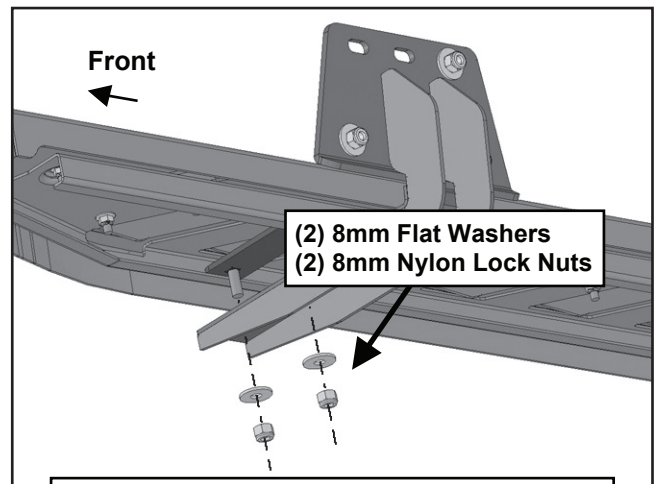

(Fig 8) Attach Running Board to front Bracket

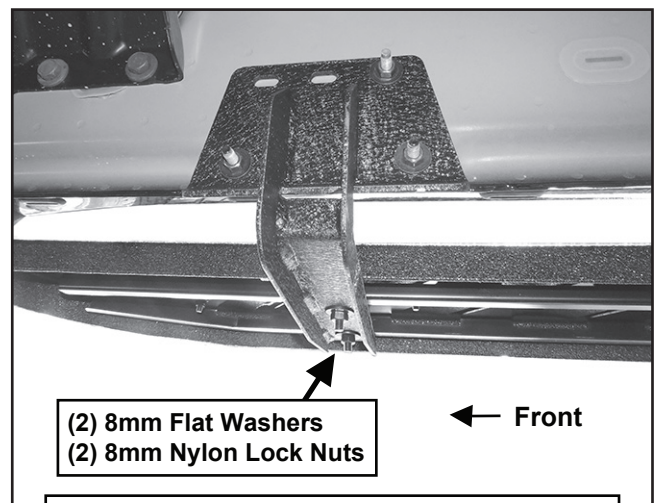

(Fig 9) Passenger/right running board pictured



TYGER[®]

STEP 7

Properly level and adjust the Running Board and fully tighten all hardware.

STEP 8

Repeat Steps 1-7 for Driver/left Running Board installation.

STEP 9

Do periodic inspections to the installation to make sure that all hardware is secure and tight.

