



TYGER OVERLAND RACK

TG-BK2U55347

BEFORE INSTALLATION

READ INSTRUCTIONS CAREFULLY BEFORE STARTING INSTALLATION. REMOVE CONTENTS FROM BOX AND VERIFY ALL PARTS ARE PRESENT. FAILURE TO IDENTIFY DAMAGE BEFORE INSTALLATION COULD LEAD TO A REJECTION OF ANY CLAIM.

TORQUE VALUES

Fastener Size	Class 8.8 Torque (ft-lbs)	Class 10.9 Torque (ft-lbs)
6mm	6-7	6-7
8mm	15-16	22-23
10mm	31-32	44-45
12mm	54-55	78-79
14mm	87-88	125-126

- x1** Driver/Left Front Support Arm
- x1** Passenger/Right Front Support Arm
- x1** Driver/Left Rear Support Arm
- x1** Passenger/Right Rear Support Arm
- x2** Side V-Plate
- x2** Side Rails
- x3** Crossbars
- x2** Crossbar Mounting Brackets
- x2** Side V-Plate Mounting Brackets
- x2** 258mm x 56mm x 3mm Foam Strips
- x2** 246mm x 72mm x 3mm Foam Strips
- x4** 240mm x 60mm x 3mm Foam Strips
- x2** 186mm x 72mm x 3mm Foam Strips
- x2** 176mm x 72mm x 3mm Foam Strips
- x56** 8mm x 25mm Torx Bolts
- x24** 8mm x 25mm Hex Bolts
- x80** 8mm Lock Washers
- x80** 8mm x 24mm OD x 2mm Flat Washers
- x56** 8mm Flange Nuts
- x12** Block Nuts
- x12** Clamping Blocks
- x12** Nut Plates
- x1** 8mm Torx Wrench

Parts List

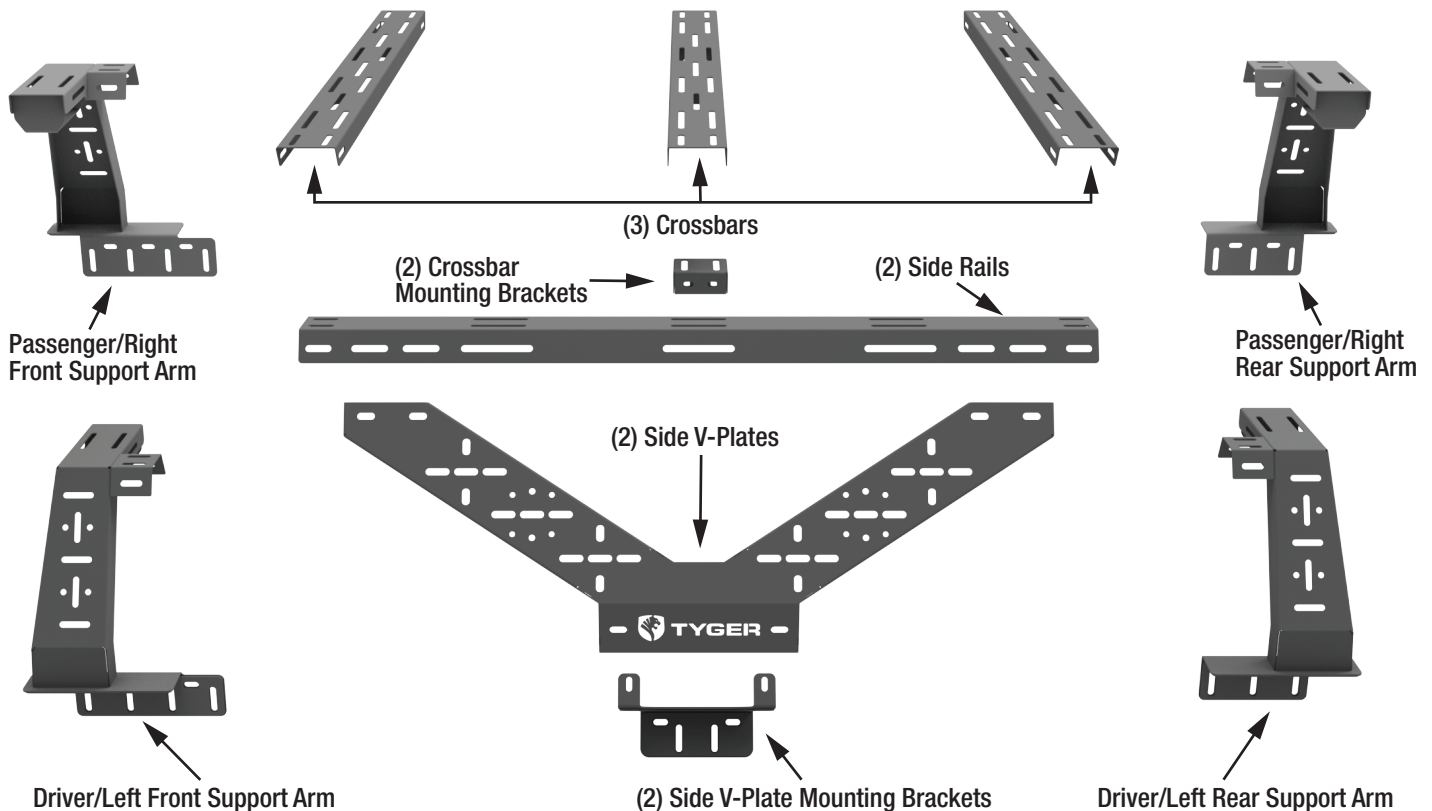

PROCEDURE:

REMOVE CONTENTS FROM BOX. VERIFY ALL PARTS ARE PRESENT. READ INSTRUCTIONS CAREFULLY BEFORE STARTING INSTALLATION. ASSISTANCE IS RECOMMENDED. DRILLING IS OPTIONAL.

STEP 1

Select the **5 different Foam Strips types**. Judging by shape, apply each Foam Strips to the corresponding vehicle facing mounting tabs of Front and Rear Support Arms and Side V-Plate Mounting Brackets (Figs 1 & 2).

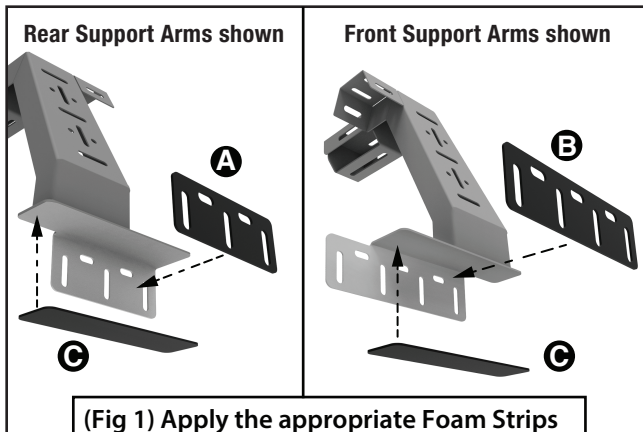

(Fig 1) Apply the appropriate Foam Strips to the inner corners of the mounting plates

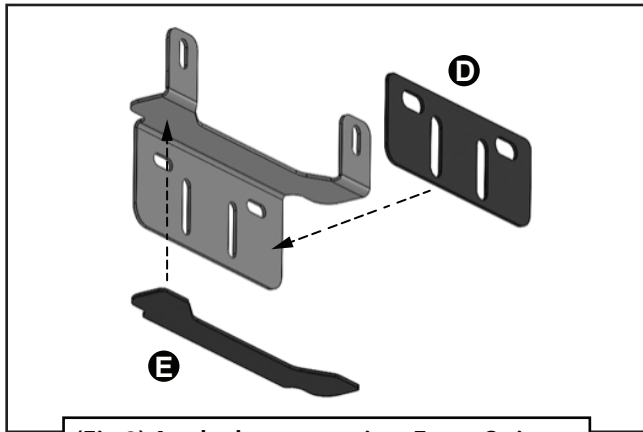

(Fig 2) Apply the appropriate Foam Strips to the inner corners of the Mounting Brackets

STEP 2

Remove tonneau cover if equipped. Select the Front Support Arms and (1) Crossbar. Attach the Crossbar to the (2) Front Arms with (8) 8mm Torx Bolts, (8) 8mm Lock washers, (8) 8mm Flat Washers and (8) 8mm Flange Nuts (Figs 3 & 4). **DO NOT** tighten hardware. If you are installing directly on the truck bed, adjust width of the Crossbar Assembly until mounting tabs are supported on bed rails.

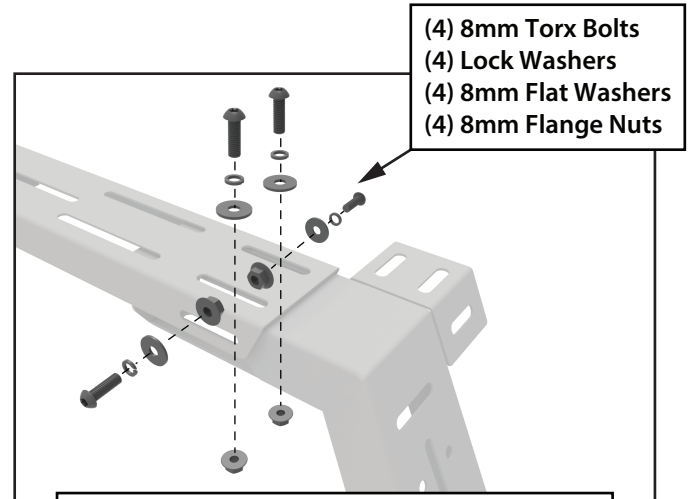

(Fig 3) Attach (1) Crossbar to the Support Arms

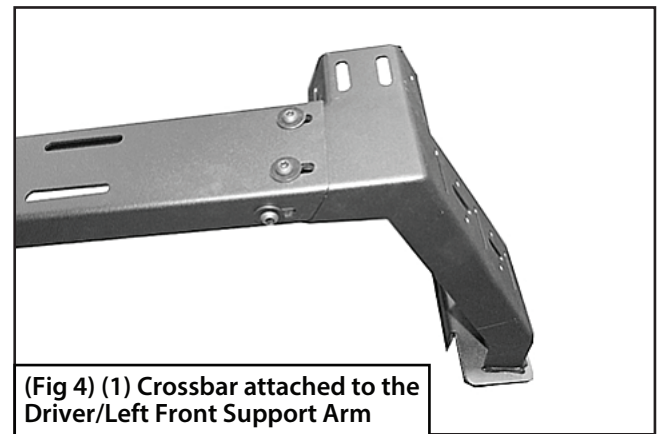

(Fig 4) (1) Crossbar attached to the Driver/Left Front Support Arm

STEP 3

Repeat **STEP 2** to attach (1) Crossbar to the (2) Rear Support Arms.

STEP 4

Select (1) Side Rail. Attach the Side Rail to the Driver/Left Front and Rear Support Arms with (8) 8mm Torx Bolts, (8) 8mm Lock washers, (8) 8mm Flat Washers and (8) 8mm Flange Nuts (Figs 5 & 6). **DO NOT** tighten hardware. Repeat this STEP to attach the remaining (1) Side Rail to the Passenger/Right Front and Rear Support Arms.

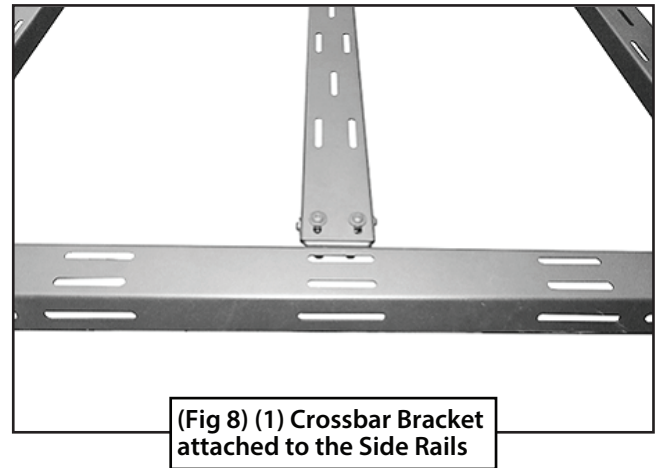
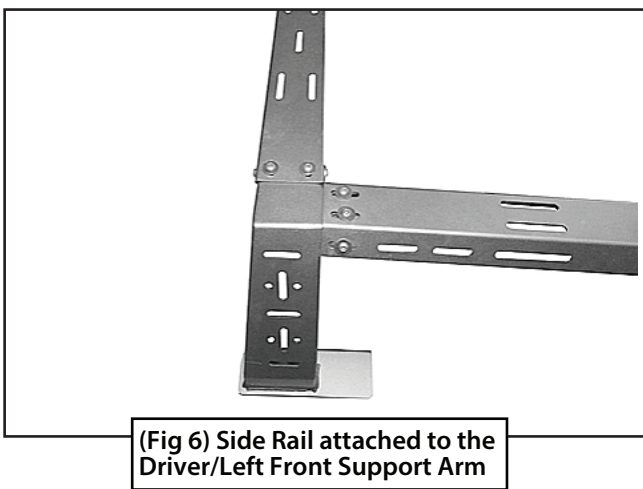
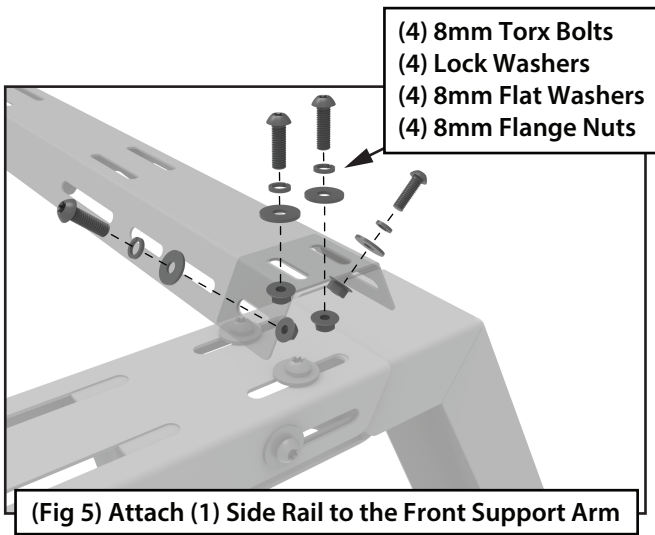

STEP 6

Locate the center slot in the (2) Side Rails. Attach the (2) Crossbar Mounting Brackets to the center slot in the Side Rails with (4) 8mm Torx Bolts, (4) 8mm Lock washers, (4) 8mm Flat Washers and (4) 8mm Flange Nuts (Figs 8 & 9). **DO NOT** tighten hardware.

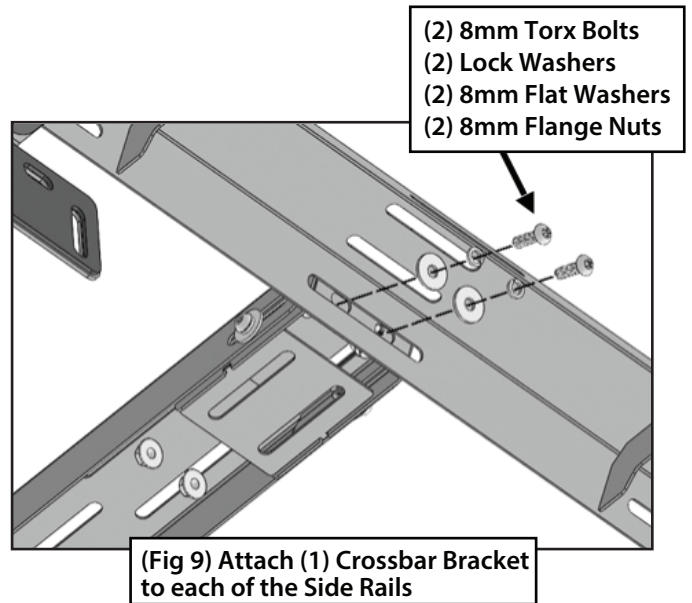

STEP 7

Select (1) Side V-Plate. Attach the Side Plate onto the underside of the Side Rail with (4) 8mm Torx Bolts, (4) 8mm Lock washers, (4) 8mm Flat Washers and (4) 8mm Flange Nuts (Figs 10 & 11). **DO NOT** tighten hardware. Repeat this **STEP** to attach the remaining (1) Side V-Plate to the underside of the other Side Rail.

STEP 5

Select the remaining (1) Crossbar and (2) Crossbar Mounting Brackets. Attach (1) Crossbar Mounting Bracket to each side of the Crossbar with (8) 8mm Torx Bolts, (8) 8mm Lock washers, (8) 8mm Flat Washers and (8) 8mm Flange Nuts (Figs 7 & 8). **DO NOT** tighten hardware.

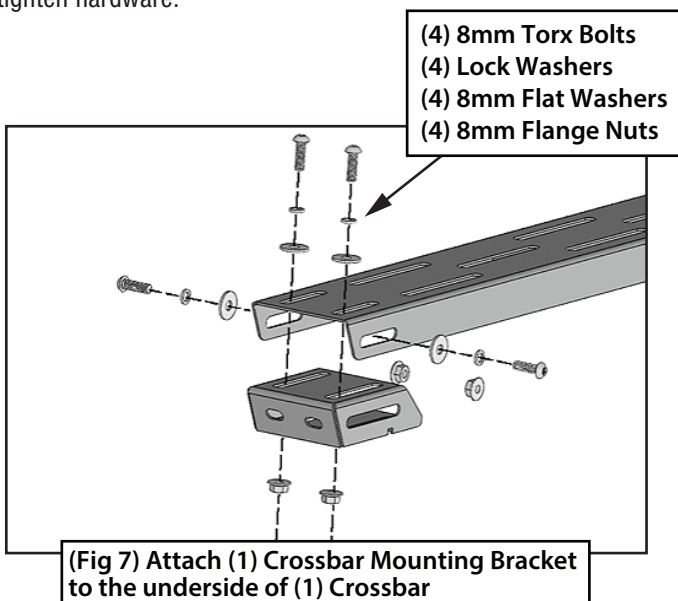

- (2) 8mm Torx Bolts
- (2) Lock Washers
- (2) 8mm Flat Washers
- (2) 8mm Flange Nuts

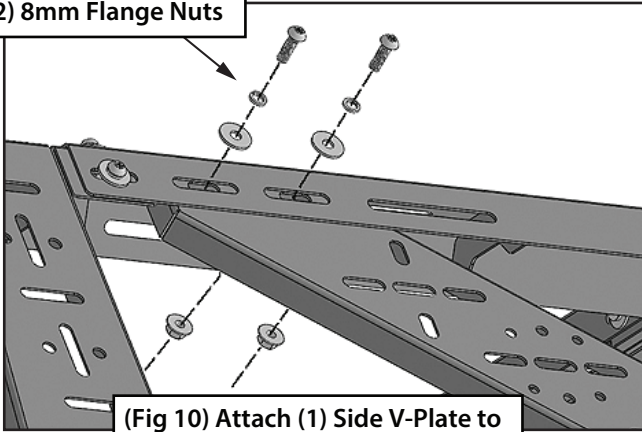

(Fig 10) Attach (1) Side V-Plate to the inside of each of the Side Rails

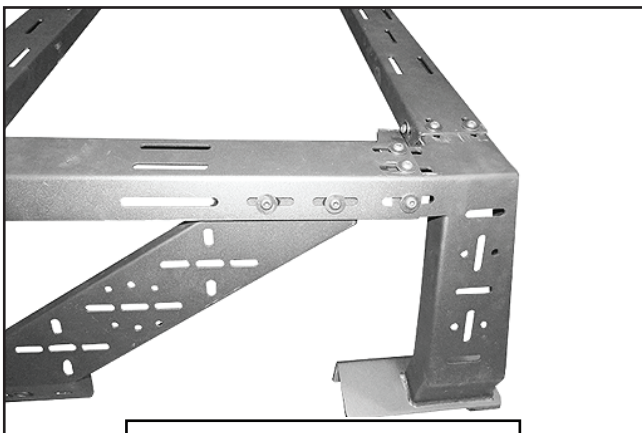

(Fig 11) (1) Side V-Plate attached to the inside of the Side Rails

STEP 8

Select (1) Side V-Plate Mounting Bracket. Attach the Mounting Bracket to the bottom inside of the Side V-Plate with (2) 8mm Torx Bolts, (2) 8mm Lock Washers, (2) 8mm Flat Washers and (2) 8mm Flange Nuts (Fig 12). **DO NOT** tighten hardware. Repeat this **STEP** to attach the remaining (1) Mounting Bracket to the other Side V-Plates.

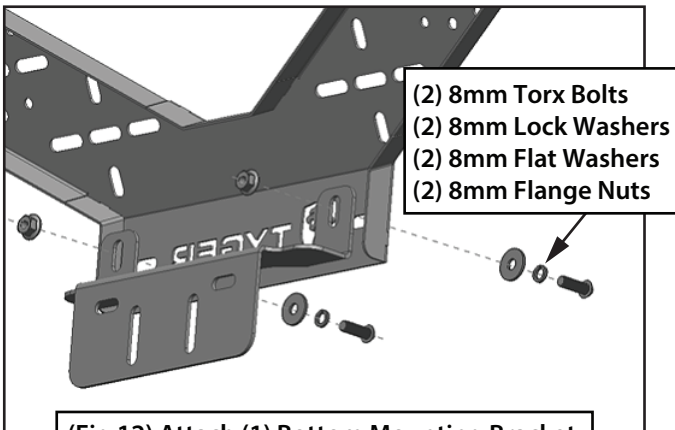

(Fig 12) Attach (1) Bottom Mounting Bracket to the bottom of each of the Side V-Plates

STEP 9

For vehicles equipped with bed rails:

a. Select the (12) Block Nuts. Insert (6) Block Nuts into each channel on each side of the bed of the vehicle (Fig 13).

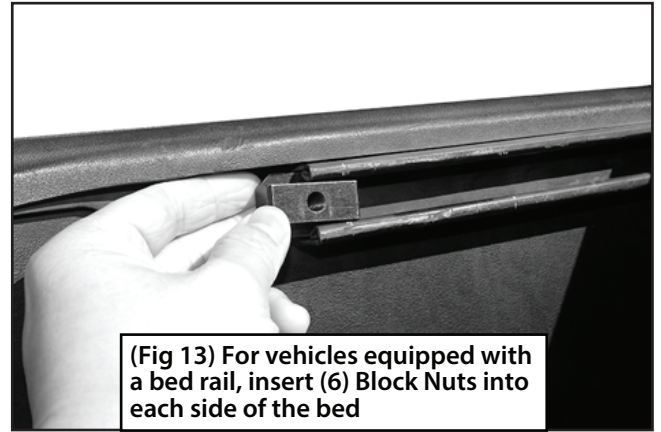

(Fig 13) For vehicles equipped with a bed rail, insert (6) Block Nuts into each side of the bed

b. With assistance, lift the Overland Bed Rack assembly onto the walls of the bed.

c. Line up the Block Nuts to the desired slot in each mounting plate, (2) Block Nuts per mounting plate (Fig 14).



(Fig 14) With assistance, place the Overland Bed Rack assembly onto the top of the bed. Line up the Block Nuts to the desired slots, (2) Block Nuts per mounting plate

d. Attach the Bed Rack to the Nut Blocks with (12) 8mm Hex Bolts, (12) 8mm Lock Washers and (12) 8mm Flat Washers (Fig 15). **DO NOT** tighten hardware

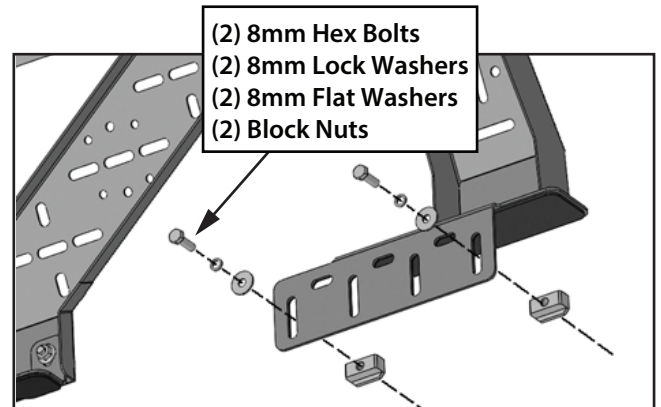

(Fig 15) Attach the Overland Bed Rack assembly to the Block Nuts

STEP 10

For vehicles not equipped with bed rails:

- a. With assistance, lift the Overland Bed Rack assembly onto the walls of the bed.
- b. Select the (12) Clamping Blocks.
- c. Line up each Clamping Block behind a slot in the mounting plates and position the lip of the Clamping Block behind the lip of the bed.
- d. Attach the Bed Rack to the Clamping Brackets with (12) 8mm Hex Bolts, (12) 8mm Lock Washers and (12) 8mm Flat Washers (Fig 16). DO NOT tighten hardware.

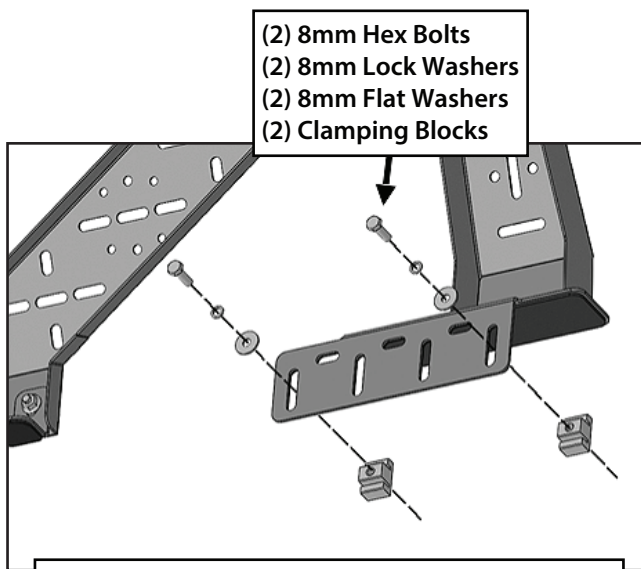

(Fig 16) For vehicles not equipped with a bed rail, but has a lip in the top of the bed wall, attach the Overland Bed Rack assembly by using the (12) Large Clamping Blocks

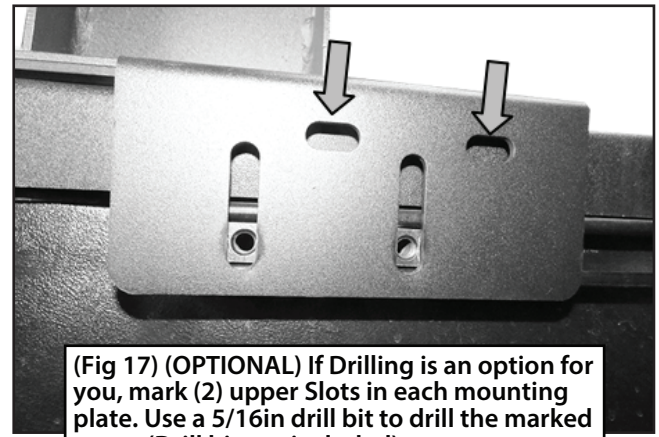

(Fig 17) (OPTIONAL) If Drilling is an option for you, mark (2) upper Slots in each mounting plate. Use a 5/16in drill bit to drill the marked areas, (Drill bit not included)

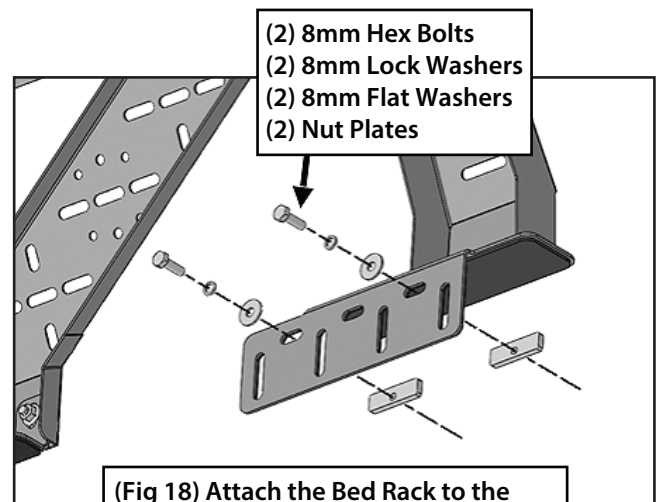

(Fig 18) Attach the Bed Rack to the drilled holes using the (12) Nuts Plates

STEP 12

Level and adjust the Overland Bed Rack and tighten all hardware.

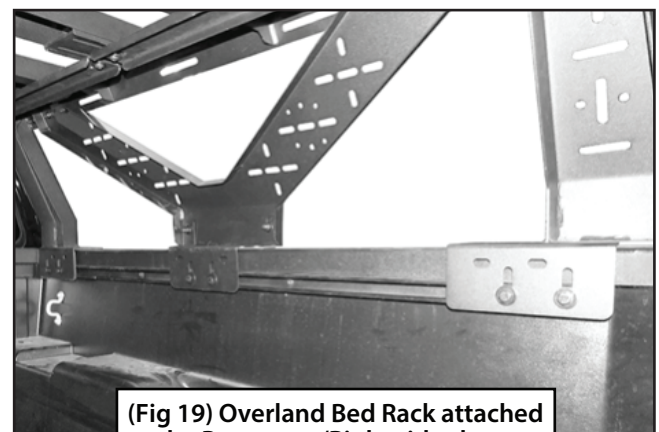

(Fig 19) Overland Bed Rack attached to the Passenger/Right side shown

STEP 13

Do periodic inspections to the installation to make sure that all hardware is secure and tight.

STEP 11

(OPTIONAL: DRILLING REQUIRED) Mark (2) upper slots in each mounting plate, (Fig 17). Temporarily remove the Bed Rack from the vehicle. With a 5/16inch drill bit, (not included) drill through the bed. Replace the Bed Rack onto the bed. Attach the Bed Rack to the drilled holes with (12) 8mm Hex Bolts, (12) 8mm Lock Washers, (12) 8mm Flat Washers and (12) Nut Plates (Fig 18). Replace the appropriate hardware. DO NOT tighten hardware.